

MPRA

Munich Personal RePEc Archive

New ways of accountancy

PAUNIĆ, ALIDA

University of Madison, Gulfport, Doctoral work

1 March 2006

Online at <https://mpra.ub.uni-muenchen.de/1727/>

MPRA Paper No. 1727, posted 16 Mar 2007 UTC



Munich Personal RePEc Archive

New ways in accountancy

Alida Paunić

University of Madison, Gulfport

March, 2007

Online at <http://mpra.ub.uni-muenchen.de>

MPRA Paper NO..

posted March 2007



Munich Personal RePEc Archive

New ways in accountancy

Alida Paunic

University of Madison, Gulfport

Abstract

The problems that are seeing by paper is to examine to what extent accounting reports can provide us with the true picture of company performance and finds the way how to broaden accounting reports in order to incorporate other relevant information (News in TV, newspapers, education, moral standards, goal achievements, position on the market, a life cycle period, computer literacy, future investment plans and possible mergers, a questions, women position etc.). It is a task of this work to examine is such an accountancy possible based on the cases of published company reports .

JEL Code: M41;M40;M14;M12;M10

Keywords: accounting general, creative accountancy, IFRS, social responsibility, accounting methods, IFRS,GAAP, new ways

1. INTRODUCTION

Accounting information should be made and employed for the purposes of correct, truthful, quick and clear picture of one company's activities. Its rule is to classify all financial information in order to lead us to right track about company success and in that way reveal the most correct market price. Fundamental analyses should point us toward today, past and future of one companies activities and reveal strengths and weaknesses of companies performance.

What should be and is are often two different roads to go-so we have excellent financial reports without interested investors, or companies with lower profit that can't be bought on the stock exchange while being sold out. Discrepancies goes from one extreme to another but the general conclusion can be stated as follows: accounting reports failed to show us the global picture and are overshadowed with advertisement made by stock exchange who promotes price policy. By incorporating latest news, rumours and future investment opportunities into price listed and publicly announced it seems that stock exchange took the leading role. Experience and accounting traditional characteristics such as cash ion teach us to be careful with that overwhelming simplicity. Simplicity is beautiful was not appreciated by cheated workers or investors where artificially made prices created on the exchange jumped or fall in order to become easy investor target. This made us to admit that part of this fault lies in our mostly cherish accounting reports. Having refused to adapt to the real, faster pace world accounting and financial reports more and more look like the management mirror of self-prayer and admiration. Published yearly financial reports have for its purpose to look nice, print on the expensive paper, with best marketing photos and skills (what is not bad), or doesn't published at all (Croatia in most cases -what is worse) started to look just like an self purpose paper without questions like humans from the Real New World movie (what is the worst of all). Without challenge to start asking new questions and filled with self-admiration we haven't went to far.

However, we have to differ the two types of financial reports :ones made and published in the capitalistic countries and ones made by fellow colleagues that work in countries in transition. While western European countries together with American counterparts have established standards to be stick to, transition economies struggle to follow the battle with the two head dragon: to quickly learn market principle, survive and that to put all nicely packed in the report (we are going to save on this part business policy type).

It seem from the start that capitalistic companies are having more than just from the Stackelbergs first mover advantage, do experience themselves all the problems and difficulties in the first 20 years of the 20 or century and have good 100 years advantage in market economy. Socialist countries can be learned quickly on the new rules but for the fair market competition it is not enough. That's why majority of healthy good working companies, that although mostly illiquid have worked for so long and stayed in game being working ground for millions of working socialist population.

With competition of multibillion western conglomerates that move its production plans quickly in order to get competitive edge in reducing price and having established most of their production while having to pay cheap for the majority of costs like salaries in China, Taiwan, Korea, and other basic inputs very slowly paced socialist economies that have to move from one system to another have little chance to survive. With the fall of Soviet Union transition to market economy was unavoidable but lack of preparations, vision, clear goals, knowledge and proper legal and regulatory tools in most cases brought significant stagnation, output fall, shrank of capital and movement of labour force. Very broad debates was inducted from the western economist that slow pace of privatisation and lack of adaptability brought socialist economies into macroeconomic difficulties, but subject is still open and need more research from the mixed team involved to identifies right moves that should have been done. Speed is important but speed without vision, and proper plan made transitional economies suspected to same consequences we are having today: trade orientation, industry collapsed, changed structures, institutions ruined, and huge transition costs that are till today still not identified and fully recognized.

The objective of this paper is to examine on Croatian case is it possible and to what extent to expand the account administration, make it more modern with all relevant information for the company included in the reports. With the help of computers all descriptive characteristics such as educational level, environmental awareness, investment plans and chances, women position can be incorporated and viewed into monthly statements. To live data about employee buyout plan, management incentives, company structure and its treats and weaknesses on the market field somewhere in the notice of yearly annual report would be very clumpy. Lets see what we have and value it properly.

Being slow and traditional accounting slowly introduced methods of financial derivatives; very couscous says a few words about environmental problems in the western countries but leaving the subject out of way in transitional economies. Having lack of support in auditing circles environment could be just seeing as the advertisement, while majority of auditors run away from unexplored and dangerous topics such as assessment of environmental dangers and its proper incorporations. Such classical problems are not welcomed while have a

danger of bad judgment, maybe lost of client and future job openings. The most of the very important topics that can influence company activities and endanger its future prospective stays unmentioned in the quantitative financial reports. It is necessary to admit that besides expenses, revenue, taxes and owners capital do exists categories that can be lined under title financial profitability: level of consumer profitability, lifestyle segment profitability, efficiency, cost of capital, sales growth, delivery channel costs; costumer measures: market share, brand name ratings, number of costumers complaint, share of wallet, Internal measures: percentage of revenue from the products, hours with costumers, productivity, efficiency, sales per referral, overhead costs and ratio, employee retention, employee productivity, turnover, personal goals alignment, number of training programs offered.

Huge palette of different subjects need to be recognized and valued, but the further problem is how, with what stuff- we need more educated accountants, auditors, regulators, brokers, media and users of such reports. Are this methods if agreed to implement bring us to our normal natural stage or bring us just the few new confusions? My task is to present necessity of such a way of thinking, like a normal way of human development where we by learning and doing actually comprehend theory and implement it in practice.

Huge decision whether to invest or not is very much depended upon uncertainties of future outcomes. These as well as expectations can be minimized by widening reports. Further risk minimisation is achieved by recognizing it and quantifying it not just by decision about provision of future most likely expenses but quantifying the risk of having educated people leave the company and take some confident information with, development of new products that could in danger our production, risk of capital leaving the country due to political instability. Theses are all facts that should be stated in reports and not just incorporated in the higher interest rate when doing the new investment study. Devil is in details can't be so, if we deal with it face to face, quantify it and publisher.

By dividing our accounting into four major groups of accounts equally recognized in the world gain can be accomplished not just for westerns but also for the transitional economies and developing world by forcing them to recognize their environmental and human values and not destroy humans as well as nature for the small amounts of money. It is a way of bribery reduction, future more healthy growth and prospect for the industry in poor regions.

First out of four groups of accounts should present current way of accountancy, based on rules made by GAAP/IFRS, the second group should be made of qualitative features made in numbers, third should clear out investment goals, prospects, possible mergers, acquisition,

and fourth possible outcome of business strategies with stated expectations, cleared or stated uncertainties and incorporated life cycle component of the corporations.

2. NEW WAYS OF ACCOUNTANCY

2.1. WHY NOT THINKING FURTHER

Accounting is in its essence very serious and traditionally structured theory but it doesn't mean it should not further develop different models in order to improve its accuracy, truthfulness and keep up with time. Very shyly it has introduced financial instruments and derivatives, still fights with serious ecological issues and provide us with one or two words about creative accountancy under which income ironing is implied. Should we stay here or move our creative thinking toward more positive ways is the question that this science is going to challenge in the future.

To incorporate new knowledge's into our daily activities is our duty in order to keep respect and not to be treated like complicated but irrelevant part of company activities. It is often the case that good performance results ends into stock price fall what is the sign that it is not the only relevant thing or we should change our ways of doing. The company should be able to measure and incorporate other measures that influence its performance such as news, TV, environmental damage, bad decisions etc countries in transition are burdened additionally with the challenge of creating stock market economy and transposing its accountancy to international standards and measuring performance. Although it is inevitable to change the system it has to be clear that market economy doesn't solve all the problems just with its implementation. Even the most advanced countries with well functioning markets the stock markets can do more harm than good to economy. The reason for this is that theoretical consideration about encouragement of savings, more efficient allocation of investment resources, the discipline of corporate management through competitive selection in the market for competitive control ,do not become reality in praxes. What the market economy does is to encourage the large companies to expand through takeovers rather than to seek organic growth, which promotes economic development. Furthermore in large number of cases the take over selection process leads to the survival of firms which are efficient in financial engineering rather than at creating the real wealth.

It is a worth of analyses to what extent one country should be pointed toward the stock market exclusively due to its negative features such as speculation, lack of long term investor commitment to corporations, short terminisam and developed more stable bank related systems like are developed by Germany and Japan. Croatia should consider this negative

aspect while undeveloped markets are often determined by high volatility of share prices. Banks system is more advantageous to undeveloped market economies due to its ability to promote the industrial development in the more efficient way. Ordinary shareholder of a large corporation has neither the ability nor the incentive to obtain necessary information what is costly to monitor management activities and thus leading him to prefer liquidity. The banks are the only outside organisation that has the means to collect necessary relevant information in order to create a long term stable economy. Things get complicated if the banks are in foreign ownership so don't have the incentive in the long term toward industrial development but are more interested in making profit. Then the only thing relevant would be efficient market with sound accounting policy, which incorporates all the relevant data. The proof for this reasoning is the number of developing countries experiencing a high degree of macro economic instability where bank based finance has tended to degenerate into inflationary / inefficient economy.

Developing country experience shortcomings in the following context:

- they develop "crony capitalism" with financing schemes for particular individuals - political connections, rather than promote long term industrial development;
- industry finance links the bank based type can in principle lead to monopolistic positions in product market and hinder entry of the new firms thereby hindering efficient market developments
- inadequate or imprudent government regulation of banks has sometimes jeopardized the integrity of the financial system as a whole the stock markets are part of economic offering in majority of developing countries so in Croatia too, there are certain dubious merits in relation to economic development.

Countries should try to protect the real industrial economy from the negative influence of the stock markets in the following ways:

- firstly, they should try to skip infancy stage as soon as possible and companies through more accurate accounting, more mature decisions, self objected goals and incorporated balance scorecard measures to try to develop employee share based plans.
- secondly, government should consider schemes of taxation
- thirdly, institutional investors such as pension funds and public agencies can be used to make more order in the market. It should be more in courage the product market competition to discipline the corporations rather than to rely on stock markets.

Before we consider how to develop more advanced accounting systems we should examine who is involved in the process of accounting information creation. When accounting information arrives to users, mostly shareholders and investors, it has already gone through the process that has started with the involvement of company executives and the board of directors. Later, auditors become involved in assessing the reliability of the accounts according to current accounting and auditing regulations. Analysts and rating agencies also become involved and report their opinion about the situation and perspectives of companies.

Agents involved in the process can negatively influence the process and bias information in the way:

- company executives and directors: they live under pressure for achieving the expected results, which is emphasized by situations like the present economic recession. This pressure and deterioration of the ethical standards and the absence of signs of good corporate governance can increase the temptation for creative accounting practices.

- accounting regulation and supervision agencies: these agencies often look away facing obvious cases of infringement of current norms

- auditors, analysts and rating agencies, the media: sometimes it is possible that auditors and analysts have made mistakes in some of the accounting standards, not detecting frauds committed by the company officials. There is a significant impact where audit firms offer both consulting and audit services to the same company. The impact that may have is in the fact that they are branches of big financial groups which also offer brokerage activities. Economic journalists often complain about the lack of relevant and reliable information that they receive from companies.

- users of accounting information: suffer from consequences of the problems mentioned.

There is another problem called expectation gap. The gap refers to what users expect from accountants and auditors, which is not the same as what they offer. Users expect the annual account information to be the reality of a company in order to take right decisions. It is often the case that what is true and fair is in reality described differently.

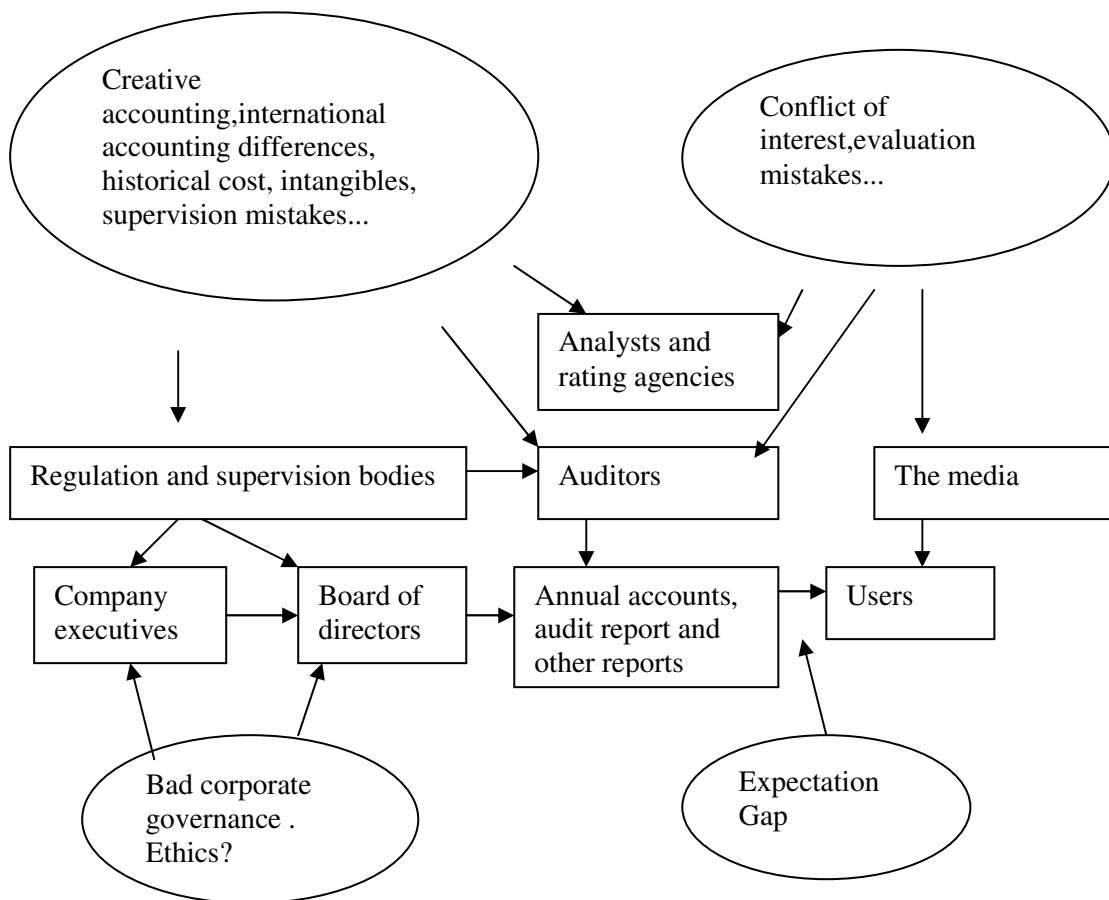

Accounting credibility is in doubt due to the following main accounting mistakes:

- a) Historical cost: where asset price should be valued according to lowest price between the acquisition price and market. Having overpriced assets that are far a way from the real value is of a little use to accounting practices.
- b) International account difference: There are many different questions which considers handling the revenue and expenses, the acknowledgment of contingencies, depreciation, provisions, stock option research, and development of acknowledgments of contingencies, pension plans, foreign currency options, derivatives, norms of consolidation and the criteria for estimating the future transactions.
- c) Intangibles: different ways of measuring the trademarks, know how, distribution network, customers, technology and others.
- c) Earning management: there exist wide scope of possibilities that managers can influence on company performance and respect.

Opportunities for further development of creative accounting together with solutions available to accounting regulators are given in the table below:

Table 1: Creative accountancy

| Opportunity to creative accounting | Solution available to accounting regulator | Accounting tradition |
|---|---|-----------------------------|
| <i>1</i> | <i>2</i> | <i>3</i> |
| Choice of accounting methods | Reduce permitted choice | Continental Europe |
| Bias estimate and predictions | Reduce scope for estimate | Continental Europe |
| Enter into artificial transaction | Substance over form | Anglo Saxon |
| Timing of genuine transaction | Prescribe revaluation | Angle Saxon |

The most frequent ethical problems that underline creative accounting is conflict of interest, clients proposed manipulation with accounts and tax evasion. The most common practices are usually conducted in the ways stated below:

- a) Expenses (goodwill depreciation or restructuring plans) charged against reserves instead including them in the profit and loss account
- b) Insufficient provisions (bad debts,)
- c) Reduction of earnings due to future loss-showing positive earnings when they are in fact incurring losses
- d) Declaring extraordinary profits as operating results
- e) Hiding the information from auditors

Table 2: Earning management techniques

| Earning management techniques | Impact on the account | How can they be detected? |
|---|--|----------------------------------|
| Increasing or reducing expenses. Not recognizing expenses from stock options | Reduction or increase in Profits, equity, assets and Debt | I,II,III,VIII |
| Considering R+D to be an expense or capitalizing it | Reduction or increase in profits, equity and assets | I,II,III |
| Expenses charged to reserves, instead of including them in the P&L account | Increase in profits | III,IV,VIII,IX |
| Off balance sheet financing through not consolidated subsidiaries of through Special Purpose Entities | Debt reduction | IV,VII |
| Changing the criteria for valuing inventories | Reduction or increase in profits, equity and assets | I,II,III,VI |
| Accounting for transactions making pessimistic or optimistic estimates about the future | Increase or reduction in profits, equity, and other assets and liabilities | I,II,III,IV |
| Generating extraordinary results in order to improve the accounts, or vice versa | Increase or reduction in profits, equity, and other assets and liabilities | V |
| Considering the extraordinary results as ordinary or vice versa | Increase or reduction in profits, equity, and other assets and | I, III, IV,V |

| | | |
|---|--|------------------|
| | liabilities | |
| Anticipating the identification of income or deflecting the identification of expenses | Increase in profits and equity | I,II,III,IV,VI |
| Deflecting the identification of income or anticipating the identification of expenses | Reduction in profits and equity | I,II,III,IV,VI |
| Fictitious sales | Increase or reduction in profits, equity, and other assets and liabilities | II,III,IV,VI,VII |
| Compensating assets and liability accounts as well as income and expenses | Increase or reduction in profits, equity, and assets | III,IV |
| Transactions valued at non market prices fake prices or willing to deceive with firms that are consolidated | Increase or reduction in profits, equity, and other assets and liabilities | II,III,IV,VI,VII |
| Not providing information about subsidiaries with the excuse that it has a high strategic value | Increase or reduction in profits, equity, and other assets and liabilities | III |

- I compare with accounting criteria of past years
- II compare with the competition's accounting criteria and indicators
- III analyse whether there are any qualifications in the audit report
- IV examine accounting books
- V analyse the extraordinary results and results from previous periods
- VI analyse the evolution of client inventories and suppliers periods
- VII analyse the operations with related firms
- VIII examine possible authorizations of special treatments

2.2. ACCOUNTING AND STOCK EXCHANGE

All the biased information provided by accountants should be corrected following the efficient market hypotheses by the market prices –which in one number that reflects all the relevant information. If this were a true this is more than the most of investors would expect to see. Efficient market hypothesis further states that if there is information that has some financial value, profit oriented investors will quickly act on it and prices will then fully discount that information. There is cost of acquiring information but it should not exceed the benefits connected with investment in security. There is constant pressure for prices to quality reveal information. Connection between the investor and their trust in the efficient market hypotheses is revealed in their approach how to manage investing. Funds can be managed actively or passively. A passive manager aim to mach the return on some index where active managers aims to purchase miss priced securities and assets and earn profit. It is clear that passive managers things that the market does not miss price securities and that managers are not able to take advantage of the miss pricing while active managers things that market miss price the securities and they are able to recognize this miss pricing. The truth is

probable somewhere in the middle on the road. Some important facts besides the importance of theory so asset pricing CAPM and APT should be considered:

- Studies of specific events, especially related to corporate announcement, suggest that the market is broadly efficient and quickly reflects certain types of information. Some other types of information like sudden unexpected earnings however need months to be fully incorporated in the market price.

- Investors have a competitive edge by obtaining private information. Careful monitoring of corporate officers who deals with shares of their own companies and seeing them how exploit abnormal returns or selling the shares in the dawn of future companies crises. Sometimes brokerage information and advice can be beneficial. But usually ends with small returns.

- Relying only to CAPM means recognizing the beta as the only relevant factor that matters so variables such as size of the firm and its P/E ratio are not related to return.

- APT is gaining more and more followers and tend to squeeze the CAPM but is fighting with similar problems too. There is not one measure that would worth for all. The proof for miss specification of the CAPM model are small stocks who are usually illiquid and bears greater risk but not in the way that is measured by beta.

- There is some evidence of return predictability –especially at the market level. Current low equity market returns could reverse in the period of a few years, and are related to the market dividend yield, the price earnings ratio and the spread of low over high-grade bond yields. There are some interesting empirical findings that underlies theoretical arguments such as that a high premium will high dividend yields that are then associated with higher return.

It is very important which type of asset pricing is taken into consideration and what information is relevant to investors. Although the major source of information are financial reports, which are on the other side even in the best case unreliable due to creative accountancy or lack of inclusion of all the relevant data. And this is to be repaired. Those factors considered by investors need to be studied and incorporated into quarterly reporting.

Investors look at the five years average growth of earnings, cash flow, sales and operating income, earnings price, and book to market. They study past performance between the growth and attributer studied and pick value stocks or those with low past growth and high market to book stocks, or glamour stocks with high past growth. Many investors use combination of factors such as accounting ratios and accounting analysis, the economic prospects of the firm whose shares are being appraised or constructs complex weighted scoring methods such as multiple regressions.

Good start would be thorough analyses of CAPM and APT models while stocks incorporate all other relevant details that are not disclosed in accounting reports. Although beta risk appertain to the single most important contribution of the academic researches to financial community article of Fama and French(1992a) has caused the academicians to re-examine the empirical support for beta's importance. Central to this CAPM intuition is the notion of risk. In a well functioning market an investors has the opportunity to invest in the less (Treasury bills) or more risky security for which should be offered a bigger gain. Sole measure of risk is called beta what is sensitivity of return of the security to the return of the market portfolio. While it is hard to measure all the securities on the world good measure is the index that is representative of a certain region. A beta higher than 1 presents stock that moves twice as much as market while the beta less than 1 means security that changes less than market. Investors by beta found systematic risk, while any other risk unsystematic one connected to the asset can be diversified away. In large portfolios the type of portfolios held by investors who determine prices only the non-diversifiable risk the systematic is relevant. Although very widely spread and popular CAPM=return on stock= risk less return beta*(S&P-risk less return) losses its credibility. Past data and findings support beta and if we use the entire history of stock returns in U.S it estimated average compensation for beta risk is 0,47% what is close to be significant. Although if we stop study in 1982 the results would be overwhelming, later showing not so good results. It is proven that in the months where market takes a deep dive high beta stocks substantially under performs low beta stock. But prosecuting attorney can use the following findings to disregard beta: the most recent experience, which is the most representative, provides weaker support to beta. If we include other variables (dummy variable for stock industry classification, dummy whether or not it is part of index, market/book value) diminish and the beta role. Slowly but surely CAPM role in financial reasoning is taken by APT, which begins with a simple description of the way in which uncertain and unpredictable events influence asset returns. Return on asset will depend on anticipated and anticipated events. Investors into their expectation of returns on individual stocks will incorporate changes that are anticipated and the market price will recognize this reflection. More than half of the return actually realized will be the result of anticipated change. Asset returns are affected by factors that are not systematic to economy but vary individually and are called idiosyncratic risk. So return on portfolio according to APT depends upon systematic risk its cost of capital plus f or actual unpredictable return on the systematic economic factors and e- return on the unsystematic/idiosyncratic factor.

$R = E + Bf + e = \text{expected return} + \text{factor sensitivity} * \text{factor movement} + \text{idiosyncratic risk}.$

There is no single systematic factor, but at least four factors: unanticipated movement in inflation, in industrial production, general cost of risk bearing.

2.3. QUALITATIVE DESCRIPTION

Fierce competition forced companies to develop standards in order to achieve more qualitative results and obtain greater market share. One of standard measures already in usage is scorecard measure. Although present in reports and in market through revealed information in the market price it is not incorporated in the standard accounting reports. Standard measures are financial, customer, internal and learning measures.

Table3: Scorecard measures

| SCORECARD MEASURES | | | |
|---|---------------------------------|--|--|
| FINANCIAL MEASURES | CUSTOMER MEASURES | INTERNAL MEASURES | LEARNING MEASURES |
| 1 | 2 | 3 | 4 |
| Customer profitability | Life cycle segment market share | Channel usage | Skill competency |
| Lifestyle segment profitability | | Product usage | |
| Product profitability | Customer satisfaction | Percentage of revenue from new | Sales productivity |
| Delivery channel cost | | Products | |
| Return on investment | Customer retention | Percentage of revenue from product | Employer satisfaction |
| Revenue growth | | Promotions | |
| Deposit service cost | Market share | Product development cycle | Employee retention |
| Return on investment | | | |
| Revenue growth | Customer acquisition | Hours with customer | Employee satisfaction |
| Deposit service cost change | | | |
| Revenue mix | Customer profitability | New product revenue | Employee productivity |
| Sales growth and target markets | | | |
| Dollars past due divided by total Dollar loans | Share of segment | Cross sale ration | Strategic job coverage ratio |
| Fee revenue divided by total revenue | Depth of relationship | Channel mix change | Strategic information availability |
| Net income | | | Ratio |
| Return on risk adjusted equity | Brand name rating | Service error rate | |
| Net income after capital charge | | Request fulfilment time | Personal goals alignments |
| Cost of capital | Number of customer complaints | Loss ratio | |
| Efficiency | | Underwriting quality audit | Revenue per employee |
| Economic value added | Closed accounts by reason | Overhead ratio | |
| Assets per employee | | Ratio of branch to on-call | Sales force average length |
| | Share of wallet | Transactions-ATM transactions | Of service |
| | Percent of target accounts | Sales per sales call | Turnover |
| | | Sales per referral | Training hours divided by FTE |
| | | New sales divided by banker | Number of training programs offered |
| | | Productivity | |
| | | Efficiency ratio | Turbulence |
| | | New product revenue as percent Of total | |

Balance scorecard is good base in considering additional elements that influence companies performance and are not expressed anywhere in numerical terms. Some of these descriptive

characteristics could lead company into bankruptcy or influence it to start considering aspects that are potential revenue drivers. Although I have started with these facts I wanted to make accounts that are partly incorporated in to legislative framework, partly are present in daily calculation but hidden behind creative accounting problems, or just not sufficiently elaborated. Although I have picked up 8 the most significant second business numbers that are elaborated in the balance scorecard, making the numerical values out of descriptive should be made even it seems to be very difficult problem at the first sight. Benchmark performance, past data, statistical measures, expert mark are all methods that are welcomed and highly recommended in order to get second part of balance sheet accounts. Having this numbers each day in front of us we would realise that oil leakage is not just the cost of cleaning the sight, but also damage expressed in numbers to environment and damage to image valued in articles and negative news reports. Than we shall be able to explain to us why our stocks so suddenly fall down for a little cost.

Out of numerous qualitative second row accounts I have chosen the following important issues that have to be incorporated numerically into annually /daily reports.

10=Ecology

11=Risk management

12=Human factor evaluation

13=Humanitarian help

14=Project preparation

15=Macroeconomic influence

16=Competition, state of afar at market, market share

17=Creativity

18=News, Press, Information, Public judgment

19=Indirect elements allocation

20=Total company mark

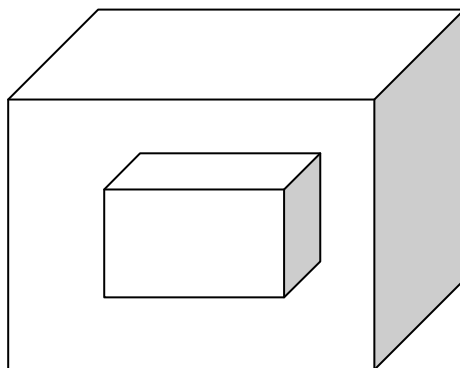

Accounting reports are as framework of the big cube, which lacks the heart or small cube, made of qualitative marks or spirit and engine of one business unit. By additional accounts situation can be put into new perspective and company achieve more respect in order to become more transparent legal subject.

2.3.1. Ecology

Rising concern for company's impact on environment caused necessity to follow measure judge compare and analyse by doing benchmarking of its influence on environment. To keep sustaining development without environment and recognising its importance is not possible in today's world. Many companies started to consider and develop manager's processes in order to create management system that would deal with growing concern about environment. Huge amounts different costs are related with the subject and goes from pollution reduction, waste management, tracing and reporting costs and investments connected with environment and paying low and insurance tariffs.

Lack of conventional accounting to follow these costs have for consequence that mangers in production don't have incentive for environmental cost reduction and are usually mostly unaware that these costs exists. There are no world consensus about size, contents and procedures connected to environmental costs management. There should be environmental accounting procedures widely accepted that should be capable to provide all necessary details connected to certain company, economic sector and national economies. Today majority of companies takes into consideration only real costs, it would be beneficial to consider and external costs caused to society. It is beneficial to evaluate these cost in the long run by long term investments while they are due to stricter regulations is going to be incorporated in the companies businesses.

The main problem of environmental management accounting today is lack of standard definition of environmental costs. Depending on various interests, they include a variety of costs, e.g., disposal costs or investment costs and, sometimes, also external costs (i.e., costs incurred outside the company, mostly to the general public). Of course, this is also true for profits of corporate environmental activities (environmental cost savings). In addition, most of these costs are usually not traced systematically and attributed to the responsible processes and products but simply summed up in general overhead. The fact that environmental costs are not fully recorded often leads to distorted calculations for improvement options. Environment protection projects aiming to prevent emissions and waste at the source (avoidance option) by better utilizing raw and auxiliary materials and

requiring less (harmful) operating materials are not recognized and implemented. The economic and ecological advantages to be derived from such measures are not used. The people in charge are often not aware that producing waste and emissions is usually more expensive than disposing of them. Experience shows that the environmental manager barely has access to the actual cost accounting documents of the company and is only aware of a tiny fraction of aggregate environmental costs. On the other hand, the controller does have most of the information but is unable to separate the environmental part without further guidance. In addition, he or she is limited to thinking within the framework of existing accounts. Also, the two departments tend to have a severe language problem.

From a macroeconomic perspective, the price of scarce raw materials, pollution and disposal do not reflect their true value and cost to society. Health hazards, repairs of contaminated sites etc. are environmental costs usually not borne by the polluter but by the general public. Although environmental accounting does exist it is still untransparent enough and publicly not shown. Some companies are trying to make separate tables in order to clarify their environmental policy but without recognizing the fact that environmental should be equal part of each monthly financial report we are also making slow progress. Environmental accounting just proves us that conventional way of reporting is antiquated and caused distorted information's. Without proper evaluation and judgments possibilities to save are unrecognised. Maybe just the fact that 20% of production causes 80% of environmental costs is enough to reconsider our ways. When environmental costs are allocated to overheads activities with low environmental damage help those who are major business polluters. This further influence ineffective price of certain product or activities and at the end reduce profitability.

Recognizing the environment as the one of our business important milestones that could make profit and loss if we are not ready to cope with the subject we should manage these costs and recognize them publicly. It is easy to do with recognizing the certain waste disposal costs, but judging the low costs, damages on image in public for not recognizing its importance are very difficult to evaluate and that is additional reasons why we should start with putting it on the separate part of our accounting reports.

Main advantages of recognizing the importance to have environmental subjects properly evaluated and recognized going as follows:

- We properly identify influence of our activities connected to environment and allocate each overhead costs that is important to certain environmental media
- by recognizing all costs we find the way of their reduction and future savings as well as preserving environment

- we eliminate those costs that don't give us additional value
- we contribute to management quality by making right decisions about capital budgeting, costs allocation, product evaluation, production mix, investment and development, and increase competitive edge and market expansion toward ecologically aware customers
- it helps by development of the whole system it supports stockholders and investors more truthfully
- reduces costs and risks of environment, grater compliance regulated from state and legislation
- increase competitive edge on the market
- made qualitative effect on environment and increase human health, establishing the green companies identity
- provide improved environmental, financial and other data toward public
- supports long term stability in business, taking into considerations economical and social environmental factors.

Problems that are connected with environment are costs and problem of rightful implementation into system. Although growing number of companies are introducing environment in their accounting system, it is still not enough. Part of the problem lays in the fact that for some of them this is just the way to advertise their products, part of the problem lays on complexity of collection and analysis of larger amount of data and lack of system that would be equally introduced in the whole world. Each company has to deal with the problem on its own way what presents additional costs.

How difficult this task is we can teach from large organisations like AT&T and American Ministry of Defence who developed one environmental system but soon abandoned it.

Environmental accounting system should be connected with all other environmental part of one business unit and play the same in the state and broader. It is up to accountant authorities as well as Governments to reduce dilemmas connected to environment in order to have reporting that is really beneficial to company and society.

Although we have seen development of some standard that deals with environmental problems like ISO 14000, EMAS , which after certification brought significant improvement there is still problem of accessibilities of these methods (those who has money can implement, but the companies operating in already hard conditions can't afford it) and lack of having the reports at spot.

It would be certainly beneficial at the level of each state to promote different instruments, rise rewards and reduce barriers of environmental consideration and implementations:

-Instruments based on information

Include rewards, education, public report, net of information, software development, demo projects etc.

-Instruments based on rewards

Includes tax reduction, subsidies, globes, Governmental contracts, Governmental Procurement procedures, tax reduction, interest and amortisation incentives

-Regulatory instruments

Regulations requires environment to be incorporated into accounting procedures, separately or included in to existing standards

-Voluntary programs

Voluntary initiatives and negotiations contracts based on national and international standards.

Environmental costs comprise both internal and external costs and relate to all costs occurred in relation to environmental damage and protection. **Environmental protection costs** include costs for prevention, disposal, planning, control, shifting actions and damage repair that can occur at companies and affect governments or people. External costs, which result from corporate activities but are not internalised via regulations and prices, are not considered. It is the role of governments to apply political instruments such as eco-taxes and emission control regulations in order to enforce the “polluter-pays” principle and thus to integrate external costs into corporate calculations. What then are corporate environmental costs? Costs incurred to deal with contaminated sites; effluent control technologies and waste disposal may first come to mind.

Measures for environmental protection comprise all activities taken for legal compliance, compliance with own commitments or voluntarily. Economic effects are not criteria, but rather the effect on prevention or reduction of environmental impact.

Corporate environmental protection expenditure includes all expenditure for measures for environmental protection of a company or on its behalf to prevent, reduce, control and document environmental aspects, impacts and hazards, as well as disposal, treatment, sanitation and clean up expenditure. The amount of corporate environmental protection expenditure is not directly related to the environmental performance of a company.

Waste and emission treatment using end-of-pipe technologies is usually the first step on the environmental protection path. End-of-pipe investments are gradually implemented as the need for legal compliance increases. Policy debates focus on the internalisation of external costs by raising prices for scarce raw materials, water and emissions, and some companies actually try to predict these price changes in their calculations. Public as well as corporate

activities aimed at environmental management are still focusing on end-of-pipe technologies, which may in the short run appear to be a fast solution, but in the long run often actually amount to more consumption of material and energy, more capital expenditure and more work hours than if measures are taken at the source.

The principle of pollution prevention does not only address the question of waste disposal but also examines where the waste comes from and how it can be prevented. Pollution prevention can be achieved by two factors, namely by changes in product design or production processes and by better housekeeping assisted by environmental management systems, with the two factors often being interlinked. Integrated environmental protection attempts to avoid waste and emissions altogether. Cleaner technologies avoid the need for hazardous operating materials, which require costly disposal methods. In contrast to expensive end-of-pipe investments, pollution prevention often significantly reduces environmental costs.

For internal company calculation of environmental costs, expenditure for environmental protection is only one side of the coin. The costs of waste and emissions include much more than the respective pollution prevention or treatment facilities.

The concept of “**waste**” has a double meaning. Waste is a material which has been purchased and paid for but which has not been turned into a marketable product. Waste is therefore indicative of production inefficiency. Thus, the costs of wasted materials, capital and labour have to be added to arrive at total corporate environmental costs and a sound basis for further calculations and decisions. Waste in this context is used as a general term for solid waste, waste water and air emissions, and thus comprises all **non-product output**. **Materials** include water and energy.

Residual waste accounting, in a subsequent phase, not only measures the costs of waste by their disposal costs, but also adds the material purchase values and pro rata production costs. The system boundary is the corporation and identical to financial reporting.

Activity-based costing improves internal company cost calculation by allocating costs typically found in overhead costs to the polluting activities and products. Significant material flows are traced throughout the company and their costs are allocated back to the polluting cost centres.

Flow cost accounting aims not merely to separate the costs of environmental protection but to detect all material flows via the company’s cost centres and to reassess production costs

and percentage amounts added in the various phases of production, like estimated scrap percentages, waste rates, etc. Technical process flow charts support this approach. While the method in detail assesses the aggregated amounts and costs of material flows, which results in a better calculation of production costs, it avoids the need to separate the environment-related share and to obtain a complete list of other environmental costs. The system boundaries are the several production processes and cost centres in a company.

The **input/output analysis of material flows** can be further subdivided from the company and process levels to the product produced. The product assessment comprises two levels. Internal company is the subdivision of the process data to the produced products. The other level of product assessment leaves the company and follows the product throughout its life cycle by adding upstream and downstream life-cycle stages. This method, based on the material flow thinking, has been incorporated into ISO 14040 .

A further step, a method called **life cycle costing**, tries to incorporate the related cost caused over the whole life cycle of a product. In life cycle costing the accounting boundaries of the company cut across, as is the normal time horizon of accounting, which causes substantial methodological and practical problems. In theory, in competitive markets, the material purchase price is expected to reflect the costs that have been incurred up to the point of sale anyway. In addition, the estimation of external costs is cumbersome and does not provide much informative value, due to the low quality and inconsistency of the data. Thus, the methodology has not gained much attention.

The Environmental Protection and Resource Management Accounts of SEEA 2000 provide for the assignment of transactions to the following classes:

- Protection of ambient air and climate;
- Wastewater management;
- Waste management;
- Protection of soil and groundwater;
- Noise and vibration abatement;
- Protection of biodiversity and landscape;
- Protection against radiation;
- Research and development;
- Other environmental protection activities.

Thus, questions of consolidation as in financial reporting arise.

Financial accounting standards have defined three methods of consolidation, depending on the share, which a company participates in another company.

1. **Full consolidation** is used by the parent company, which controls the majority of the voting rights of a subsidiary (50 to 100 per cent). The parent overtakes the complete profit and loss account by adding together assets, liabilities, equity, earnings and expenses and deletes all internal deliveries within the group.

2. **The equity method** is used for associates, which are neither a subsidiary nor a joint venture to the parent, but in which it has a significant influence (between 20 to 49 per cent). The equity method considers the actual change in value of the share of the equity, but does not integrate sales, assets or liabilities. All internal deliveries are eliminated.

3. **The proportionate method** is applied for investments between 1 to 19 per cent of the share capital as well as for joint ventures. Typically, the value of the shares in the books remains unadjusted until significant changes occur. In environmental reports the degree of ownership of sites is hardly ever mentioned. Also the method of consolidation is hardly ever disclosed or even discussed. In practice, many companies fully consolidate subsidiaries of more than 50 per cent, but without adjustment for internal deliveries, and neglecting minority investments. Thus, the consolidating practices and system boundaries for financial and environmental reporting can differ significantly. Comparing and relating financial data like turnover and EBIT to environmental data like energy use or total CO₂ emissions is often significantly hampered.

Problems connected to environment stretches not just to implement it in the company but also to implement it by full consolidation method. It is important to have in mind large variety of facts when doing consolidation:

1. All sites and subsidiaries should apply the same definitions for data collection.
2. All sites and subsidiaries should apply the same input/output chart of accounts for the material flow balance.
3. Before benchmarking sites, process flow charts must be compared and harmonized.
4. All sites and subsidiaries should apply the same consolidation methods.
5. The consolidation principles should be disclosed.
6. Internal deliveries should be adjusted.
7. When calculating key figures, the same consolidating principles should be used as in financial and environmental accounting.
8. In environmental reports, total sales, EBIT and share of each company should be disclosed.

This all point to believe that it would be better to keep all environmental data at the separate account in the following way:

10 01 Investment

10 01 Direct (01..02..03..4....010)= air, water, ground water, waste, etc 10

- 10 01 Indirect (11 12 13...)
- 10 02 Costs
 - 10 02 0 Direct costs (0 400 material for water , where 400 costs for water
(1 401 energy for air etc)
 - 10 02 1 Indirect costs (0 447 payments to waste water ; 1 449 books for
- 10 03 (1...100) Allocation to products
- 10 04 (1..100) Allocation to production spots

2.3.2. Risk management

The second important chapter that should be stated separately on accounting reports should be connected to risk management. This subject also needed a long time to have its own standard in IFRS (IFRS 39) It defines derivative definition, four categories of financial assets, definition regarding recognition and measurement, transaction costs, embedded derivatives, initial recognition, date of trading versus date of settlement, gains and losses from investments in derivatives, value impairment and non paid financial assets etc. In order to incorporate risk management it is necessary to be familiar with its properties.

Financial world have two basic measures that values investment: the first one is CAPM and the second one is presented by APM. While we think about CAPM as the intuitive approach over relation between risk and return made model which has been acceptable to regulatory bodies and widely implemented, the scholars find themselves more attached to the Arbitrage Pricing Model which trays to capture all the other possibilities that are related to the cost of capital and the price of security such as inflation, interest, industry growth and instead of market index measure introduce several types of systematic risks.

Before I explain why we should incorporate risk management more thoroughly in to financial reports, distinction between these two models should be very well understood.

Although the CAPM has gained the major role in calculating the cost of capital among regulatory bodies it loses its popularity among the economist. The main reason for that are deficiencies in its theoretical structure. With the new theory- Arbitrage Pricing – assets pricing is not just intuitively comprehend but also has a solid theoretical support and can be understand easily.

The bases of the CAPM is that the risk and return are strongly correlated and those investors who bears more risk should be rewarded for it- by greater return. The measure of it is beta. The discontent with the CAPM came from the very meaning of beta, which is the sensitivity of securities return with the market. Market presents all the securities existing in the world,

which induced strong disagreement by Mr. Ross with the CAPM model. He argued that taking S&P as the representative of the market as efficient mean variance market is not correct and is far away from the sufficient measure of risk and return on stocks or cost of capital.

The simplified formula for the CAPM is :

$$\text{Return on stock (cost of capital)} = \text{constant} + b^* (\text{return on S\&P500})$$

When $b=1$ that means the if market goes up for the certain percent than the stock goes up for the same amount; If it is bigger than 1 it jumps more than market, but if it is less than 1 it returns goes less than market moves. Rarely, there is the case of negative beta what means that it follows the opposite trend than those of the market (example are beta for gold, insurance industry). Null beta equalizes cost of capital with the risk less rate of return. All the risk is on the side of beta and is called the non-diversifiable, market or systematic risk and it is the only relevant risk while the other type of risk that is solely related to security is no market risk and can be diversified away.

The parents, who independently attributed to the creation of the CAPM, are Mr. Sharpe, Linner and Mossin. If we imagine the short sales without risk less lending or borrowing we shall face each investor with the same efficient line with ABC representing the minimum set portfolio. This efficient frontier will defer among investors due to the differences in expectations.

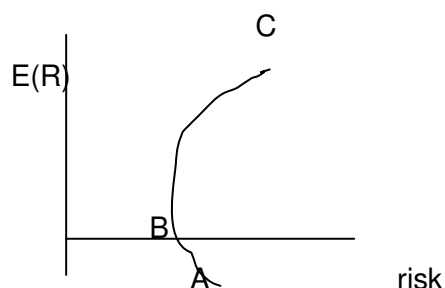

By introduction of risk less lending and borrowing rate we obtain portfolio that lies between risk less rate and the efficient set as the tangent line. Investors satisfy their preferences over risk and return by combining portfolio A with the lending or borrowing. In this case they have the same expectation and held the same risky portfolio comprised of all risky assets. The market portfolio is the basket of all portfolios in the market in proportion to their market value and the line that connects the risk free rate and the market portfolio presents the capital line.

Along the capital line lays efficient portfolios and expected return on efficient portfolio can be seen as formula:

Expected return=Price of time+(Price of risk)*(Amount of risk)

$$R_e = R_f + (R_m - R_f / \sigma_M) * \sigma_e$$

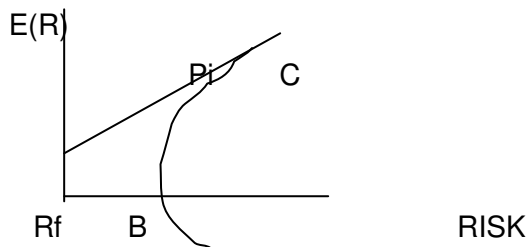

In the case of two portfolios return is measured as

$$R_p = x * R_a + (1-x) * R_b$$

$$b = x * b_a + (1-x) * b_b$$

$$R_p = a + c * b = a + c * (x * b_a + (1-x) * b_b)$$

Beta of the market portfolio is 1 and the for the risk less rate it is zero what putting together and substituting makes the security market line:

$$R_i = a + b * C$$

$$R_f = a + 0 * C$$

$$R_m = R_f + b * (1)$$

$$R_i = R_f + b * (R_m - R_f)$$

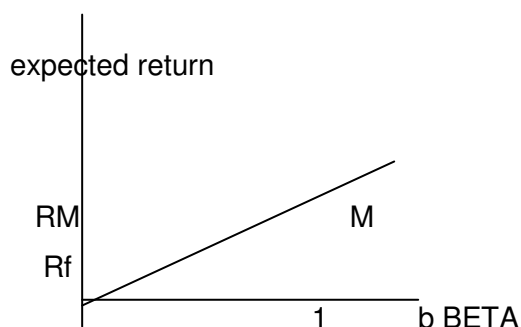

Derivation of the CAPM can be made with a little bit complicated approach where we take derivation from the equation $q = (R_p - R_f) / \sigma_p$

$$Y * (X_1 \sigma_1 + X_2 \sigma_2 + X_3 \sigma_3 + \dots + X_N \sigma_N) = R_k - R_f$$

$$\text{COV}(R_k, R_m) = E((R_k - R_m)(\sum X_i R_i - \sum R_i X_i))$$

$$\text{COV}(R_k, R_m) = X_1 E(R_k - R_k)(R_1 - R_1) + \dots + X_N E(R_k - R_k)(R_N - R_N)$$

$$Y \cdot \text{COV}(R_k, R_m) = R_k - R_m$$

Since it holds for all securities it must hold for the portfolio of all the securities and

$$\text{COV}(R_m, R_m) = \sigma^2 M$$

$$y \cdot \text{COV}(R_m, R_m) = R_k - R_m$$

$$y = R_k - R_m / \text{cov}(R_m, R_m)$$

$$Y = R_k - R_m / \sigma^2 M$$

$$R_k = R_f + R_m - R_f / \sigma^2 M \cdot (\text{cov}(R_k, R_m))$$

$$R_k = R_f + b \cdot (R_k - R_m)$$

If we introduce prices in our model we are obtaining following formula:

$$R = \frac{\text{Ending value} - \text{Beginning value}}{\text{Beginning value}}$$

$$R_i = Y_i / P_i - 1$$

$$R_m = Y_m / P_m - 1$$

$$R_k = R_f + b \cdot (R_m - R_f)$$

$$= R_f + b \cdot (Y_m / P_m - 1 - R_f)$$

$$Y_1 / P_1 - 1 = R_f + (Y_m / P_m - 1 - R_f) \cdot (\text{cov}(Y_1, Y_m) / P_1 P_m) / (1 / P_m^2) \cdot \text{VAR } y_m$$

$$Y_i = R_f \cdot P_1 + (Y_m - R_f \cdot P_m) \cdot \text{COV}(y_i, y_m) / \text{VAR}(Y_m)$$

$$P_i = 1 / R_f \cdot (Y_i - (Y_m - r_f \cdot P_m) \cdot \text{cov}(Y_i, Y_m) / \text{var}(Y_m))$$

$$\text{market price for risk is equal} = Y_m - (R_f - P_m) / (\text{var}(Y_m))^{1/2}$$

$$\text{risk for any asset is equal} = \text{cov}(Y_i, Y_m) / \text{var}(Y_m)^{1/2}$$

Unlike the CAPM, the APM starts from assumption that there are more factors that influence the movements in the stocks. These factors are most commonly: *inflation, interest rate change, market index, economy growth, and risk premium, industrial production*. Each security has its own sensitivity to index – index is the same for all securities just this sensitivity is different. This is the important innovation in the CAPM, so APT could be seen as the longer improved hand of the first model because it allows that portfolio and security dependent upon more systematic risk not just the market one as the measure of everything. In this way measure the cost of capital and the price of security more correctly. It can be seen as following formula:

APT = $E + b_1 f_1 + e$ = Expected return + Factor sensitivity * Factor movement + Idiosyncratic risk



Systematic risk

unsystematic risk

$$R_i = a + b_1 I_1 + b_2 I_2 + \dots + e$$

To fully describe the model we have to assume that the $E(e_i e_j) = 0$ for $i \neq j$ and $E(e_i (I_i - I_j)) = 0$ for all stocks and indexes.

If I_i rises for one unit $-b_i$ shows us how much will this affect the return?

$$R_i = a + \sum b_{ij} I_j + e_j \quad R_i = R_f + \sum b_{ij} Y_j$$

We can derive the APT from the CAPM model, which is valid as well as in simple case of the one index as and in the more complex case.

CAPM is the return generating form that can be written as

$$R_i = a + b R_m + e$$

If returns are depending on the single index model which is in fact the return on the market model as well as the risk less rate

$$R_i = R_f + p(R_m - R_f)$$

In the multi index model APT is having the following form:

$$R_i = a_i + b_{i1} I_1 + b_{i2} I_2 + e$$

$$R_i = R_f + b_{i1} Y_1 + b_{i2} Y_2 + e$$

If we substitute the $y = p(R_m - R_f)$ we are getting the

$$R_i = R_f + p b (R_m - R_f) + p b (R_m - R_f)$$

$$R_i = R_f + (p_1 b_1 + p_2 b_2) (R_m - R_f)$$

$$R_i = R_f + p(R_m - R_f)$$

The large portfolios are determined by the systematic risk and not by the idiosyncratic one and by choosing different portfolios with different sensitivities we can establish indices for the factor and calculate the cost of capital. Sensitivity in this case presents = return on the portfolio-risk free interest rate.

The best way to compare these two methods is to take the real life situation and calculate the past performance of the cost of capital in both ways. One of the excellent examples where we also possess the data or numbers for the longer period of time in the past are regulated utilities. They are strongly depended upon interest rate and this is one index factor.

Having calculated cost of capital we establish that the CAPM underestimates the cost of capital for the 20% comparing to the APT what points us toward the APT model as the superior over CAPM.

Having thinking about abandoning beta and CAPM in our calculation we have to examine are we jumping over conclusion and that one case is not the reason the totally exclude CAPM from our observation. We have to start from the very beginning of the theory and consider all the advantages and disadvantages we are experiencing. The unattainable real situation behind the theoretical assumptions of CAPM doesn't have to mean the death for beta.

Why the framework is not good enough and actually lad us to suspect in the basic model besides the Ross reasoning about deficiencies of S&P top act as the market the following assumptions will explain:

a) ***There are no transaction costs***

It is obvious that it is not a realistic assumption while transaction costs are present in every financial activity we made. Thereby become very important as the huger the amount comes in question or the size of the portfolio grows. Some investment is trying to reduce these costs choosing the bank or financial intuitions whose change is smaller but it is certainly comes into consideration in thinking about investing. But if we add the transaction cost into our calculations we could unnecessarily complicate the model what is not purpose of any investment activity.

b) ***Assets are infinitely divisible***

This assumption suggests that investors can take any position regarding their wealth and are capable of buying each stock at the price they want. Of course it is not so. We usually divide things in our mathematical calculation and derive them but unfortunately we need a certain quantity of money to buy 1 stock –it is not possible with the one dollar to buy a certain stock .In some cases on the Stock Exchange we need to have a money to buy 100 stocks because they are traded in that way as a lot.

c) ***Absence of personal income tax***

Individuals are indifferent between the forms of investment whether is it the capital gain or dividends. The most serious investors take tax rules into consideration before making their investment decisions. They need to consider the percentage that has to be paid for the capital gains and what is for dividends. Low tax bracket investors can hold higher dividend stocks than other taxpayers.

The following formula presents our return on asset with the tax calculation incorporated in it:

$$E(R) = R_f + b^*(E(R_M) - R_f) - t^*(\sigma_M - R_f) + t^*(\sigma_i - R_f)$$

Where are:

σ_M = dividend yield on the market portfolio

σ_i = dividend yield on the stock

t = tax rates on capital gain

The investor should be informed about countries specific rules considering the taxes (for example America is having the bigger dividend tax than capital gain one) because this policy is not the same for all countries. Even in one country there are constant changes: we were witness that American Government made a proposal to cut a taxes on the capital gains recently. This was very well accepted among those who have huge quantities of money to invest in the projects that brings them capital gains. Although it was advertised as the huge tax cut for the majority people it presents a little while they invest their money into pension funds. I have to add that tax cut as the solely measure makes a little to improve economy growth in the short run, only it has effects in the longer time.

d) Individual cannot affect the price of a stock by his selling or buying activities

One individual cannot significantly influence the price of certain stock or all of them –that is the truth. But it also stands that people united are changing things –for better or for worse. We should consider the large investment houses, pension and insurance houses, and groups of individuals that effect prices. Mr.Lindenberg make analyses of the equilibrium position which is influenced by price affect or. He founds out that price affect or is rewarded for the greater risk in the way that he has in his portfolio more quantities of risky assets than average investor and has the power to influence the prices.

e) Investors make their decisions solely based on expected return and standard deviation

Investors do form their decisions about investment on the basis of expected return and risk or standard deviation the they are related to it, but not solely. He depends upon many other factors such as his wealth, time preference, utility, taxes they faces, margin that are required to satisfy rate of which he can lend or borrow etc.

f) Unlimited short sales are allowed

The investor can sell short any amount of any shares- also very questionable in the times of depression it is not possible to sell because nobody wants to buy. Sometimes the shares are not on the market available. Example for this is countries in transition that don't have developed stock market so although some companies are stock ones their shares are not traded in the public.

g) The investor can engage in the unlimited lending and borrowing at the risk less rate

This assumption says that investor can lend or borrow any amount of funds at the risk less rate of return. Lending is usually possible at the one rate and the borrowing at the other. It is the case that this is not uniform either but depends upon investor and his amount of wealth. It is shown on the graphs below some possibilities that are present in the real world.

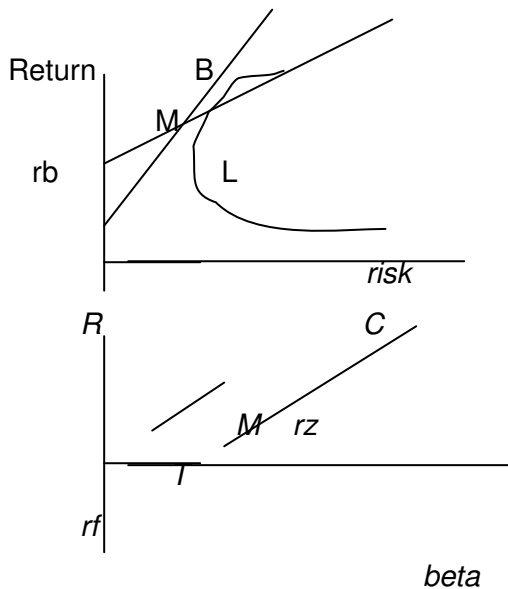

The first graph presents different rate for lending what is r_l and that is of course smaller one, the rate at which investors borrows is bigger one and depends upon the banks rate of borrowing and are presented as r_b . The market portfolio lies between the L and M

h) Investors are homogeneous in their expectations concerning the mean and variance

The investors don't have the same expectations –different individuals have different wealth situation and utilities. Investors marginal rate of substitutions are different. It is still possible to reach the equilibrium but under more difficult circumstances, which ask, us to know not just expected return, variance and covariance but each investors utility.

i) Investors value the time period all in the same way

j) All assets are marketable and can be sold on the market including human capital

This assumption considers even human capital to be marketable goods what is not so in the real world. Although the unemployment is modern evil the man is not the slave and cannot be bought.

If we put into consideration no marketable goods we can calculate the expected return according the following formula:

$$E(R_i) = R_f + (E(R_M) - R_f) \left(\frac{\sigma_{M^2} + PH/PM \text{ cov}(R_M, R_H)}{\sigma_{M^2} + PH/PM \text{ cov}(R_M, R_H)} \right) \left(\text{COV}(R_j, R_M) + PH/PM \text{ cov}(R_j, R_H) \right)$$

PH is the total value of the non marketable assets and

PM is the total value of the marketable assets

We won't be much wrong if we use the standard CAPM if the significance of the non market assets is small and has low correlating with it. For example depends upon human capital and their wages has a low impact on economy.

2.3.2.0. Different tests of CAPM

To test the CAPM we have to collect, examine and test using econometric models data we found in process about stock price and their return behaviour. The bases for CAPM are that higher risk beta is related to the return, this connection goes linearly and that there is no added return for the non-market risk. Also we should examine the standard form of the CAPM and the two-factor model and find relationship between them. The differences are that standard model have intercept at the R_f and the slope of $R_M - R_f$ all in the beta space and that the two factor model has the intercept at the R_z and the slope of $R_m - R_z$.

2.3.2.1. A simple test of CAPM

Mr. Cooper and Sharpe using data ran the simple test from the New York Stock Exchange in the period for 1931-1967. They divided the stocks into deciles based on their beta. Running the regression based on this data they came to conclusion that the 95% of the variation in return are explained by differences in beta. This relationship is positive, strong and linear $R = 5,54 + 12,75b$ but intercept is greater than the risk free rates so are satisfies two factor form of CAPM.

This early test consisted of two parts of examination in order to establish the connection between the reality and theory: the first part is aimed to estimate beta using the time series model and the second part is dealing with test of hypotheses that stands behind the CAPM using the cross section data. The economist who made it empirically was Mr. Linter and Douglas. The first step was to collect data from the stocks return against the average return of all the stocks and having the first part of regression $R_i = a + bR_M + e$. The second part was running the cross sectional regression and had following variables

$$R_i = a_1 + a_2 \beta_i + a_3 \text{Se}_2 + n$$

Where Se_2 = residual variable from the first part regression-variance of e

$a_1 = R_f$ or R_z

$a_2 = (R_M - R_f)$ or $(R_m - R_z)$

$a_3 =$ should be zero, residual value.

The results they came to was made some serious doubts about CAPM because they found R_f or R_z to be 10,8 much greater than should be normally, a_1 was also much larger than expected and $a_3=0,23$

Possible problems were that R_f is not constant and varies over time so is correlated with the RM and our beta is biased estimate of the true one. It is examined and proved in praxes that when interest goes up market goes down so this negative correlation affects the biasing the intercept in the second regression and makes the slope going down. The second possible solution to the problem can be the case of no linearity, which causes the intercept to go up and slope down. The third possible cause is the presence of heteroscedasticity.

2.3.2.2. Black, Jensen and Scholes test

The first one who made the depth in analysis of time series regression to test the CAPM were Mr Black Jensen and Scholes. They start from the time series model:

$R_i - R_f = a + b \cdot (R_m - R_f) + e$ and then take the large number of securities which put into portfolios according to past beta on each security in order to avoid biases in observed beta. Then rank the security according to their beta and collect the return on each. After that they established ten portfolios according to this data. If the model of CAPM was true and a would be equal zero. Each portfolio was regressed against the market, intercept and beta. They found that if beta was greater than one intercept was negative and in the other way around beta less than one intercept should be positive. They also found the strong conclusion to support the two models CAPM that is strongly linearly related. -

This was mathematically proved as:

$$R_i = R_z(1-b) + b \cdot R_m + e$$

$$R_i = a + R_f(1-b) + b \cdot R_m + e$$

$$a = (R_z - R_f)(1-b) \text{ if } b < 1 \quad a > 0 \text{ if } b > 1 \quad a < 0$$

The second part of analyses was related to the cross sectional test. The beta was estimated from the residuals so residual risk was serving as the proxy for the beta risk. This risk is smaller when we are measuring the portfolio beta than stocks beta. The result that was obtained was positive intercept and evidence of correctness of the two-factor model at the 98%.

2.3.2.3. Test of Fama And Macbeth

Mr Fama and MacBeth (1972) started as the previous economist did with the first part of regression based on the 20 portfolios of securities and then continue with the second part of

regression cross section for each month. They tried to prove that in the equation they ran in the following equation some assumptions are statistically proved

$$R_i = y_0 + y_1 b - y_2 b^2 + y_3 2S_e + n$$

$E(y_3) = 0$ residual risk is not effecting return

$E(y_2) = 0$ there are no nonlinear ties

$E(y_1) < 0$

They concluded that there is positive linear relationship between the beta and risk and residual risk had no such as importance as it had in the studies of Holes.

In the other words residual value has no influence on the future different performance of this stock.

It is interesting fact that Fama together with French in they article in the Journal of Economics (1992) argued on the other hand that there is no relationship between the beta and return. They proved using portfolios data that returns are more influenced by the firm size and book value of equity to market value of equity. If this theory will be sustained all the CAPM reasoning will be meaningless.

2.3.2.4. Test of Ross

The major opponents to the CAPM model are Ross and Roll. They firmly suggest that using Stock Index as the benchmark is just the wasting of our time. Why? Firstly it excludes two major assets categories. Human capital and real estate. Secondly, it is impossible too construct the market portfolio which measures and proper weights the returns of all assets in the while world. Consequences for that are that CAPM doesn't worth and even if we found the very good index which could serve as the market index ad compare it with the other equally good it is possible that we shall have totally different results. They argued that either that each security lies on the Security Market line or security diverge from it on the unpredictable way. CAPM is worthless in either case.

2.3.2.5. Tests that support beta

The worst thing that could happened according to managers is downside risk when make their investment decisions. It is proved that in the case when market raises the investors with the higher beta have bigger gains than those who have a low beta stocks. That is valid and in the opposite case –falling market and bigger losses for the higher beta stocks. This is tested in the 1987 excess market return was –22,43% with the estimated slope of –22,59% where a low beta stock experience return on the –17,10% and higher beta –33,76% in the 10 portfolios.

Beta can have impact on behaviour of the investors. If they believe that beta is related to the return they can bid the market and evaluate their performance to the market index. Although the measure such as book to market is proved to be important factor higher B/M portfolio outperforms the low B/M portfolio for the 7,2% a year, but it is only proxy for the risk and many doubts that this is the write measure for the return for the stock.

The competitor to the beta is the size effect. Measuring the returns on the small index with the S&P in the period of 79-91 we found standard error for the difference in returns equal 3,63% per year. This is not significant but it is the finger of good that we can't judge the performance of one factor just for the small period of time and takes one factor solely. Nevertheless, we have recently found more and more critics pointed out toward the CAPM and beta as the measure of the return for stocks we have to consider thoroughly and carefully all the evidence pro and contra this approach. It is certainly helpful that we are having alternative model APT that is born out of the first one with the little improvements in his performance but this doesn't mean that we have to say goodbye to the beta. If we take into consideration the past performance of beta we would found that the average estimated compensation for the beta risk is not significantly different from the average excess return on the market. In the situation of extreme values and down market beta seems to predict returns in the best possible ways.

On the other side we have to admit that Mr. Roll has certainly right in his conclusions and that we are living in the fast changing environment. We have to adopt our way of thinking in economy as we used to do in other fields of our activities (new technology, medicine, behaviour, way of living and thinking). This could mean to admit and accept that beta has in the last ten year diminishing meaning.

I wish to conclude this reasoning that we should not abandon beta but incorporate it in the new model that considers other factors that are important for the future returns. Economy as the other science should improve its models not living in the hindsight's performance but reach for the new ways (APT, dynamic optimization etc). Theses new ways should be directed toward more interdisciplinary approach and connection between financial and accounting reasoning too.

Under account 11 we should incorporate all risks and instruments connected with investments in risk instruments such as options, forwards, futures and derivatives like puts, calls, weather climate derivatives, energy derivatives, different combinations etc.

11 Risk Management

- 11 01 Financial asset
- 11 02 Financial obligation
- 11 03 Risk assessment with each investment
- 11 04 Fair value
- 11 05 Instrument debt
- 11 06 Transaction costs

2.3.3. Human evaluation

Organisation without quality workers, good mission strategy, modern vision and sound values and principles are in danger to become low profit even bankrupt legal entity. In order to about “black strategy” more and more companies develop different strategies in order to employ quality workers, provide them good working conditions and evaluate their work on the proper way. To value machines and incorporate them in the assets side without admitting the human value is a report that lacks basic ingredients. Making long-term relationship includes not just the right person to be on the right place but additional education, learning, incentive payments for extraordinary achievements and relationship that is filled with trust, honesty and both side interest. Along these streets various problems can arise due to the unclear rights and obligations and without transparent policy that starts from the top (management) to bottom (common workers) of this business induced relationships.

Corporate world include variety of different roles for their stakeholders which can be basically determined as principal / agent relationship. An owner acts as the principal when considering whom to give to play a role of a manager who, on the other hand, behaves as the agent. This question is important when considering creating a contract, which would, in the constant situation of uncertainty satisfy both aims: maximise the owner’s profit and give the employee the optimal provision. Main actors in different roles are: managers in the relationship with the employee can act as the principal who with the role of maximizing profit have to find best fit people for the role as the directors, heads of departments to work for him as agents. The story goes until every employee no matter is it a sales person, factory line worker, accountant, planner, engineer, mathematician, director or the manager himself are not playing the role as an agent. Although they all are employed in order to maximise the profit of the firm, and to increase the wealth to the owner their behaviour if not carefully observed and reworded is usually pointed toward self-interest behaviour. Before signing the contract the agent could have some hidden information about his performance, and provoke adverse selection to be made by principal, it is also possible that well suitable candidate afterwards

show some signs of moral hazard. Facing with the world where only the change exist and uncertainty is present in the market condition, we have to put our agent and principal in the uncertainty situation and consider what kind reasoning is present in one and another mind to be able to create the contract in which each side would not just benefit from it but also live in merited and rightful working environment.

Principal employs the agents to work on his behalf under terms determined by contract in uncertain situations. His decisions are dependent upon three variables: those that can be managed and controlled by the decision maker and are endogenous to his working activities such as the level of output etc; the second type of variables depend upon economic system as the whole and are exogenous to the individual model and the third type of variables are environmental ones which are not effected by the economic system itself but influence it greatly (weather). A specific set of vectors of environmental variables presents state of the world, which is exhaustive, mutually exclusive, and outside the decision maker management. In this situation where decision have to be taken in the period one for the state contingent situation in the period two, decision make have to act according to his preferences. He would take the prospect which is the combination of the probability and income I order of transitivity. When the person is in the situation to choose among the different prospects he will put on his lists of priorities the one which gives him a better results. If it is given certain income of y_1 then the standard prospect for y_1 equals $P_0 = (v_1, y_0 - y_0)$ where the v_1 is the probability of getting the y_1 . Or in other words if we take value of income in the certain range than individual can find probability of getting the better results in the standard prospect, he is indifferent between the certain income and the standard prospect. A compound prospect is the situation when different outcomes can occur or S different ways can lead to y_a or y_b . Many professionals are free of risk an illusion that means that they don't expect only two outcomes to happen and rationally evaluate every possibility. One a decision maker conduct series of paired comparison he chooses among the different projects in order to maximise the expected utility. This utility function stretches from above by 1 or y_b and underneath by 0 or y_a . This expected utility have the characteristics that has certain value and is differentiated at least twice in the entire domain. If we marked the utility function as $v(y)$ than derivatives are $v'(y)$ $v''(y)$ for all y in the (y_a, y_b) interval. The first derivative is the marginal utility of income while the second presents the rate at which marginal utility of income changes with income. We can observe decision maker preference, indifference or neutrality toward risk by starting with his expectation of prospect $P = (p, y_1, y_2)$ and expected value of the outcomes $y = py_1 + (1-p)y_2$

The certainty equivalent is the amount that would be regarded as good as prospect for the decision maker and is received for certain. There are three possibilities that could happen in our observations:

- a) Certainty equivalent is the same as the expected value of the outcomes or $y_c = y$ or $v(y_c) = v(y) = pv(y_1) + (1-p)v(y_2)$ and is the main feature of the risk neutral person
- b) $y_c < y$ The prospect is valued greatly by the decision maker than its expected value or $v(y_c) < v(y)$ and describes the risk averse person.
- c) The third possibility is that prospect is valued more than expected value $y_c > y$ or $v(y_c) > v(y)$

These three faces of the utility function are easily explainable by graph and properties of the convex and concave curves. Strictly the risk neutrality represents concave curve, convex for the risk preference one and linear or utility line $\langle y_1, y_2 \rangle$.

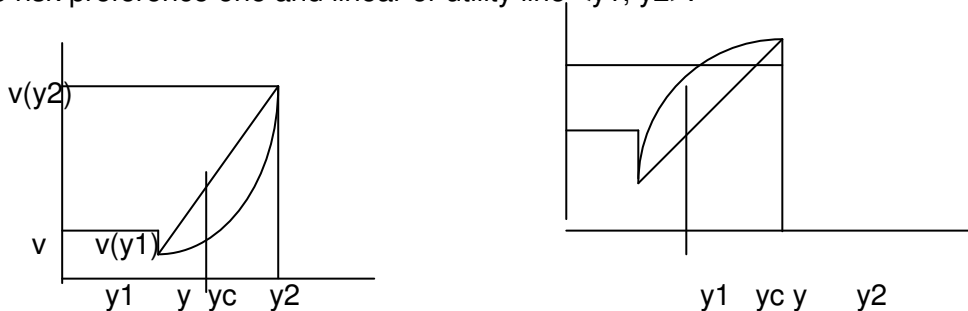

The slope of the line $-mn-$ is $(v(y_2) - v(y_1)) / (y_2 - y_1)$ and its height at y is $f(y) = v(y_1) + (v(y_2) - v(y_1))(y - y_1) / (y_2 - y_1)$

Following this we can calculate the height at y if we know that $y = py_1 + (1-p)y_2$.

$$\begin{aligned}
 f(y) &= v(y_1) + [(v(y_2) - v(y_1)) * (py_1 + (1-p)y_2 - y_1)] / (y_2 - y_1) \\
 &= v(y_1) + ((v(y_2) - v(y_1)) * (1-p)(y_2 - y_1)) / (y_2 - y_1) \\
 &= v(y_1) + (v(y_2) - v(y_1))(1-p) \\
 &= v(y_1) + v(y_2) - v(y_1) - pv(y_2) - v(y_1)p \\
 &= pv(y_1) + (1-p)v(y_2) = v
 \end{aligned}$$

A person that is risk averse would prefer certain income rather than risky prospects $P(p, y_1, y_2)$ and he is willing to give up from the certain income to avoid risky prospects what is usually called the risk premium or cost of risk.

It can be defined as $v(y - r) = pv(y_1) + (1-p)v(y_2)$. Comparing the risky project with the certain income we are getting

$$v(y_c) = v = v(y - r) \quad y_c = y - r \quad r = y - y_c$$

The employer have to think about that result that occur as the result of the employee action should not be rewarded on the base of the solely results, performance or considering the outside factors but looking at the same time all the influences and admit risk in every decision. He should look upon how people behave in risky situation, how they choose among different risky choices and how they share the risk?

It is known from everyday situation that keeping all the treasure at one place is not very smart because it doesn't provide enough protection against risk. The solution to that problem is in the diversification which is one person decision maker chooses to deal with the several small prospects instead of one in order to reduce the risk. When numerous persons share income the best way to protect them against risk is pooling. It is easy to prove this statement using two individuals model. Lets say we are observing two employees with the probabilities p to get income y_1 and the probabilities $(1-p)$ to achieve y_2 . Then the expected utility of the first person is

$V_A = p v(y_1) + (1-p)v(y_2)$. But if they agree to share the risks and put their total income in the pool and share it the expected utility for the person A will be

$$v_{2A} = p^2 v(y_1) + (2p(1-p) * (y_1 + y_2)/2) + (1-p)^2 v(y_2)$$

To show that it is more profitable to agree upon share income principle we have to subtract utility two from one.

$$(V_2 - V_1)_A = v(y_1)(p^2 - p) + (1-p)^2 - (1-p)v(y_2) + 2p(1-p)v(y_1 + y_2)/2 = \\ = 2p(1-p)(v(1/2y_1 + 1/2y_2) - 1/2v_1 - 1/2v_2)$$

Since a is risk averse than concave curve is represented by his utility and the last brackets result must be positive.

This pooling of risk make person a more secure that in the case of illness or bad economic situating he will reduce he risk of having the wage.

When n individuals who are risk averse decides to pool their equally distributed incomes in the share pool they can expect that each will get $1/n$ of the total income. In the non-identical distribution we are observing incomes of the individuals that can be positively and negatively correlated. When they are perfectly positively correlated there are no benefit for pooling because individuals would never be able to degree about degree of pooling. In the negatively correlated income situation the individuals would prefer pooling and benefit from it.

2.3.3.1. Optimal contracts in relation to various shareholders

When we start creation of various job related contracts we have to consider agents type of approach toward risk. The majority contracts are made for the risk averse agent and try to solve the problem of maximization the wealth of the principal at the one side and keep, reward or punish the worker on the other. There are no lots of cases where risk neutrality finds its position in the praxes on contrary neutrality implies problems that are even more complicated than in considering a good contract for the risk averse person, for which would be enough to give an example: putting all the risk on the manager you have employed means he is running the business, deciding and is responsible for everything that could happen what is very hard to find because he would have his own business. In the case of some financial losses such an individual would be asked to provide the lost capital but may

lack necessary funds for that. Creating the proper contract for the firm's shareholders include observing the costs or effort that employee is giving $C(e)$ and profit that is elicited from his labour $P(e)$. As we concluded above only performance based payment does not include efficient risk sharing. Employer can't observe every thing that are related with the employee and can reward systematically just those actions that are observable. Due to different jobs duties: professors, line workers, managers, accountants are not equally evaluated in their performance because they have jobs whose results can be observable or not, they attitude toward the risk is different which vary significantly different jobs rewards and models of compensation are created.

2.3.3.2. Incentive compensation

There are many jobs that apply contracts based on the performance of employee. Linear compensation is suitable for line workers, sales personnel, factory workers, management etc. Creating a contract means thinking about efficient risk sharing in which every person have to share one tiny part of the total risk. The employee should be protected from the random effects that influence their results of labour. If contract is not suitably made it produces costs that resulted from inefficient risk sharing and equals total risk premium for real compensation payment minus risk premium that is connected with the efficient risk sharing. When principal starts in determining one a contract he includes first two component: one is certain income and the other part of the agent income depends upon his effort and results. Although as we mentioned there are situation and business circumstances for which the agent can't influence results of his performance and their part is also included in the contract. This is the basic thinking about what should be that basis for our contract and can be expressed as.

$$W = A + B(e + x + vy)$$

A presents certain income

B intensity of incentives

E workers effort

X results from his effort resulted demand for some product for the salesman

Y is not connected with the effort but with the factors outside the workers control such as industry demand

V is relative wage given to y

Although it is the employer that bears the majority of financial risk, it would not be beneficial that agent has all the time certain income because his attitude toward effort and income increasing would be without motivation. This kind of problem was one of the obstacles that socialist system failed economically in competition with the capitalist one: lack of competition

among workers, they were too secure on their working places and were not adequately rewarded for good performance. When the employer 's salary is based on performance his certainty equivalent is measured as the expected compensation minus costs from providing effort and risk premium. It is mathematically seen as:

$$A+B (e+x+ vy) - C(e) - \frac{1}{2} r B^2 \text{Var} (x+ vy)$$

The aim of the employer is to maximize his certainty equivalent $\text{Max}(P(e)-(A+Be))$ or to maximize the difference between profit and costs for the employees wages.

Total maximization of wealth for the agent and principal is sum of this two equation and is represented by the total certain equivalent= $P(e) -C(e) -1/2 r B^2 \text{Var}(x+ vy)$.

What socialist system failed to achieve hoping that worker will provide the maximum effort for his working duties, the competitive one observe and noticed that workers will provide more effort if increase in marginal costs equals more of the expected income B . $B=C'(e)$. The level at which employees provide their effort is set that marginal costs from this effort equals marginal revenue and for the extra effort he expects bigger incentives.

This is presented on the graph below.

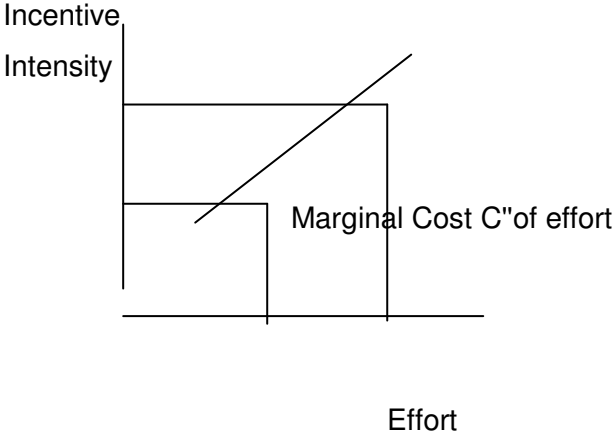

The best way how to imply this contract in praxes is by setting an effort level on e_1 and observe the other parameters such as B, A, y in the way to satisfy condition that $B= C'(e)$ and maximise the total certain equivalent. If we want to observe how much intensity have to be provided or to calculated B_2-B_1 when the effort level is increased from the e_1 to e_2 we multiply the slope of the marginal cost curve C'' with the difference in the effort level.

2.3.3.3. Informative ness principle

This principle states that in designing compensation contracts the $-v-$ should be chosen in a way to minimize the variance $\text{Var}(x+vy)$. The terms that increase the error with which the performance is measured should be omitted and those that decrease error with which the

worker is rewarded should be included. In designing the contract we are looking at the $\text{Var}(x+vy)$ and $\text{Var}(x)$ for which the smaller variance is included in our model of compensation formula. We can write the term $\text{Var}(x+vy)$ as the $\text{Var}(x)+v^2\text{Var}(y)+2v\text{Cov}(x,y)$ and try to minimise this expression. To set the v at the optimal level we calculate the $-\text{Cov}(x,y)/\text{Var}(y)$ and interpret it in the following way: if the x and y are independent the v is set and zero and Cov between this two terms is also zero. If they are positively correlated as in the case when total growth in the certain industry for example food production means better performance and outcome in the certain factory then in order to reduce variance we have to set our $-v$ to be negative. When the general conditions are bad we have to correct the payment by setting a positive $-v$ and in the good times to understand that good performance may be due to the luck and not the effort and improve it by making a minus in front of $-v$. In the other case x and y are negatively correlated if they move in opposite direction the best way is to set v to be positive.

This type of creation of the contract is especially suitable for the comparison between the jobs such as managers one and trying to reward them adequately. To compare the performance between the two managers we have to divide their performance in the way that depend on effort, random component of his performance and the outside factors that influence both of them. To understand it better we can write $z_A = e_A + x_A + x_C$ $z_B = e_B + x_B + x_C$. We can compare this two workers by calculate the absolute or relative measure ($z_A - z_B$) in their performance and find absolute variance $\text{Var}(X_A) + \text{Var}(X_C)$ or relative one $\text{Var}(x_A) + \text{Var}(X_b)$. It is better to compensate their performance on the absolute standard if the $\text{Var}(x_C)$ is less than a $\text{Var}(X_A)$ because the randomness that affects the both workers is less then their standard performance. Also, following the same reasoning if the $\text{Var}(x_A)$ less than a $\text{Var}(x_C)$ the relative performance measure is preferred.

2.3.3.4. Incentive intensity principle

How to optimally set the intensity of incentives depends upon the following facts: added profit that is achieved by extra effort, the risk tolerance of the agent, the precision with which the job is done and agents responsiveness to effort. It should balance the marginal benefits with the marginal costs of increasing the intensity of incentives and is presented bay the graph and formula below.

Total certain equivalent is derived with the respect to e and set at zero.

$$0 = P'(e) - C'(e) - r \cdot V \cdot C'(e) \cdot C''(e)$$

If we set $C'(e) = B$ the formula further develops as $0 = P'(e) - B - r \cdot V \cdot B \cdot C''(e)$ $B =$
 $P'(e) / (1 + r \cdot V \cdot C''(e))$

$$P'(e) / C''(e)$$

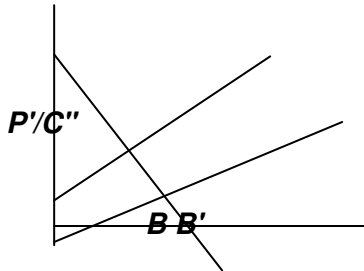

2.3.3.5. Monitoring intensity principle

One of the ways by which the employer wants to increase bigger productivity by workers is by monitoring. We can determine the cost of monitoring as the $M(V)$ and recognise it as the minimum amount to be spent to achieve the as low as possible variance. The lower monitoring costs means bigger variance. When we include this cost of the employer in the total certain equivalent equation we are getting $= P(e) - C(e) - 1/2 r \cdot v \cdot B^2 - M(V)$

In order to maximise the total certain equivalent we have to derive this equation with the respect to V and are getting: $-1/2 r B^2 - M'(V) = 0$ The most efficient solution would be to set V to the amount of $-1/2 r B^2$.

2.3.3.6. The equal compensation principle

When job duties varies among two or more different activities and employer cannot observe it than it would be beneficial for the employer to imply the equal compensation principle. It states than when the tasks, which are conducted by the employee results with the equal marginal benefits he should work on the both of tasks, otherwise he should put effort only in those tasks which gives bigger benefit.

2.3.3.7. Inter temporal incentives

For the assign job task the principal set standards, which are usually, based on the past performance results. In that way expected payment equals certain equivalent plus $(e+x)$ or $E = A+B (e+x)$ The certain equivalent than is $A = e-B (E+X)$ and says if we establish the standards too high than the expected payments is low, otherwise employer would work less with the greater salary but with the total profit much less. Performance standard measures how long it needs for the worker to finish his job and efficiency that is achieved in his performance. Good results set higher standards, which can lead to a greater standard if a more effort is evolved. This situation at the end brings the backward results because the worker is expected to achieve all the time this higher standard. This is known as ratchet effect and also dated back in the history (Egypt - Jews slaves) it was first observed by the Soviet economist who write about setting higher performance after every quartile results.

2.3.3.8 .Contracts are able to achieve objects of principal and agents

As the title suggests it is possible to create the contract to satisfy the agent and principal expectations achieve the Nash equilibrium in the employment surrounding. If the principal offers trust to the employee and if that trust is honoured then they both are better off. This situation lasts until one deters in his «good» behaviour and cheats no matter is it an employee or employer. The employer can suffer from the moral hazard problem and subjectivity in the judgments of the agent's behaviour and in that way don't recognize the valuable worker and pay him inadequately or dismiss him. The employees are usually inclined to shirking and they will cheat the employer if his gain from it is bigger than the difference between his current wage and the wage he can get on the market in the case he is faired. If this statement is put in the space-time framework we are getting the following formula:

$g > p(w-w')N$ where N denotes multiple time relationship between these two and p stands for the probability of being caught. As he N grows the worker's reputation rise, harder to get new employment it is more costly to cheat. It is a well known saying that satisfied worker doesn't cheat what means that higher payment guarantees the quality of labour. While principal reasoning is to reduce costs but still count o good worker his job is to minimise the costs of monitoring and workers payment Minim. $M(p)+w$ where w is : $w = w' + g/Np$ than he should minimise the equation :

$M(p)+w'+g/Np$ with respect to p

$$0 = M'(p) - g/p^2 * N$$

$$0 < M''(p) + 2g/p^3 * N$$

Optimal point is on the intersection of the falling curve $g/p^2 \cdot N$ and rising $M'(p)$.

With the longer relationship less monitoring is necessary and more trust is offered. Reputation becomes more valuable through time and employee gets credit for the past good behaviour. When owner of the firm is near retirement he tries to keep the firm's good standards as to attract with its reputation potential buyers. Companies that have problems and face potential bankruptcy - they produce low quality products, also experience end of game behaviour.

Making right contract and observing the modern firm makes recognizing the important facts besides the each success and that should be stated separately as

-Ownership

Type of ownership is the first step that determines relationships in the company. If it is owned by a single or a small group with each owner liable for the debts of firm connections are different from the ownership where it stretches from several thousand people or other firms and financial organisations.

-Control

If one individual or a small group owns the firm it is likely that someone with a significant ownership share will exercise overall control. Where the ownership is dispersed over many individuals overall control is exercised by a board of directors acting as fiduciary representatives of the owners and comprising employees of the firm and outside directors. When the firm is partly owned by another firm or financial organization some members of this group will often represent it in the board.

The central weakness of classical accounting is the absence of analyses and its measurement not just in accounting reports of the role of information and of behaviour of the owner of the firm and his interaction with manager. A simple assumption of a given profit constraints sweeps a lot of important issues under the carpet. A central implication of the separation of ownership from control is the asymmetry of information it creates between managers and owner. If an owner knew as much as the manager about the profit making possibilities of the firm the owner could threaten to punish observed deviations from profit maximizing behaviour and so ensure that they did not take place. If an owner perceives that the manager's information is inevitably going to be superior to his own he try to devise the contract which takes account of this asymmetry of information and provides the manager with an incentive to take at least some account of the owner's objectives. Relevant models are provided by principal agent theory, which provides general analyses of the following situation. A principal P employs an agent A to carry out some activity on her behalf. A must

choose some decision variable e which determines outcome $x = x(e, Q)$. In this function Q is a random variable with known distribution. In one type of model that of moral hazard A must choose e before Q is known. P observes the outcome x but cannot observe either e or Q and so is unable to ensure that A in fact chooses the value of e P would prefer. Her problem is then to design a contract that rewards A according to the outcome value x taking into account any tendency A might have to choose a value of e , which is non-optimal for P . In a second type of model that of adverse selection A knows Q before e is chosen while again P cannot observe e or Q .

-Organization

A hierarchical structure will exist between the people who direct carry out the basic activities of production selling output and buying inputs on the other hand and the people exercising overall control on the other. This means fulfilment of the number of activities: to translate broad policy objectives formulated by controllers into specific plans; to co-ordinate the separate activities at lower levels and ensure consistency of plans; to monitor performance; transmit information on this up to controllers and implement incentive systems, and to provide information with which overall policy objectives can be formulated. The larger and greater the diversity of the basic production and selling activities of the organization the more extended and complex this hierarchical structure will be.

-Information

The operation of the firm will generate information (reports from salesman on demand conditions, performance of production processes) and also activities will be undertaken to acquire it (market research technological research and development) This information must be transmitted to the points in the firm at which it is required for decision making. The information will rarely be complete so the decisions will generally be taken under varying degrees of uncertainty.

-Conflict

Objectives plans and decisions will generally be formulated or taken by more than one individual. Conflicts may arise between these individuals because of lack of objective information, and beliefs may differ about possible outcomes of decisions and the relative likelihoods of these or preference orderings of the individuals over the outcomes of the decision may differ. Source of conflict true to the last reason is when given outcome of a decision may benefit different decision takers in different ways, so that conflict would be avoided only if they subordinated their own self-interest to some common objective, possibly of the firm's shareholders. Workers can refuse to work if decisions about wages hours and conditions of work do or do not take a certain form; shareholders can sell their shares if

profits are low and so on. The conflicts that exist among such groups will be reflected in decision taking.

2.3.4. Humanitarian help

The aim of this study and work is to prove that companies are not living only in the world made of 39 accounting standards. Recognizing it and stressing importance of humanitarian work our daily job has a higher purpose. Boring, repetitive work on machines or making the same all over again becomes more important if we know that our work is helping our families as well as those who are having a hard moments due to natural catastrophe, illness or war damage. Putting it clearly in our accounting report underlined with real situation and names in annual reports workers are additionally incentives

Humanitarian help can be divided into following groups:

- 10 04 1 Donations
- 10 04 1 1 Donations free of taxes
- 10 04 1 2 Donations above tax free amount
- 10 04 2 1 Sponsorship
- 10 04 3 1 Education
- 10 04 4 1 Internal courses
- 10 04 4 1 1 Time and money of the internal teacher
- 10 04 4 1 2 Time and money lost of employees
- 10 04 4 1 3 Material cost –direct connected with internal courses
- 10 04 4 1 4 Indirect costs- opportunistic costs, literature, books, etc
- 10 04 5 1 External courses
- 10 05 6 1 Heath care (must be for certain , on voluntary bases etc)
- 10 05 Representations

2.3.5. Project preparation

Good project preparation is also one of the milestones of the significant influence on company's performance. It is possible if not properly followed and reported to outside investors that some huge negative and positive surprises can arise as consequence of certain activities. Many investment method and accounting procedures are in place but it is important that they are clearly put in accounting reports and properly explained. This would save a lot of ambiguities that are in front of potential investors, current shareholders, future customers and employees themselves.

Due to the investments in various fields of our lives, humans came a long way from the Stone Age to the atomic and computer era -even a space travel becomes a common thing. On this journey we have to deal with investments in knowledge, machines, factories, food production etc. and today modern man makes very day to day decisions – buying a new machine, investing in portfolio, buying a land, apartment - in what to invest with his current state of income to get the biggest, safest and quickest return. Governments and factory managers are dealing with the same problem just in the another scope considering the money, expected rate of return, willingness to risk, social factors, environmental impacts on their decision and the enormous number of input variables that should be considered, classified and taken into calculations. Without investments we would be living in the same caves as we used to live long-time before but at the same staying at the same spot or worse making a wrong decisions in what to invest and when. Investments can lead us to the smaller or greater disasters: from loosing the small quantities of money to the bankruptcy. Further negative sides of potential failure of creating and implementing the big projects influence our lives as unemployment, environmental disaster, loosing the competitive advantage over similar company, loosing the political power etc. Successful project varies from investing in our knowledge and get a huger salary to the increasing the state wealth and quality of life. We had and still have a huger number of factories in Croatia that was bombastically announce as the biggest investment in the region and turn out to be the biggest failures stay empty without purpose: -closed factory in Obrovac of the producing the hydrated aluminium for making aluminium. It turns out that the territory is out of reach with the hydrated alumni a and that it should be transported from some other places, which makes transportation costs a bigger and production the more expensive and factory turned into bankruptcy. A couple of years ago one more factory was closed which was producing the copper situated in the longest cove on the Adriatic cost and with its pollution chased away the entire tourist population, causing additionally the environmental damage.

2.3.5.1. Different methods of investment calculation

To do the things right we have, after establishing our goal, to choose among the several techniques of calculating the appraisal of investment and its benefit. The most popular one is the Net Present Value. Why it is so superior over its alternatives I will explain by depicting from each calculations its strength and weaknesses.

- a) Payback method is still very alive and in everyday use due to fast calculation $N = I/C$ investment / annual cash flow in obtaining the result to investors when their get their money back. Being simple and risk less it takes into account the project that has a smaller period of payback. It is useful as the first step in thinking about undertaking some

investment project but without taking into calculation the whole period of investment, its time value, losing information about working capital and taking into account just investment costs loses a much of its credibility especially in analyses of huge projects.

b) Avoiding some pitfalls in the first method we can come to the second one –Return on the capital employed- = average profit/ total or average investment-its name and way of coming to results tells us that it expands its result to the whole life period of project and uses working capital instead of operating cost. Although managers like to deal with the return in percentage and to compare the projects on the bases of its profitability it suffers from the lack of time dimension and some ambiguity in calculating. Namely, using the accounting methods of obtaining profit we are not having the full picture how this is calculated – depreciation can be obtained in different ways from the straight line it the double declining or accelerating cost recovering system thus making our results incomparable to the similar one.

c) Two previous methods have a great deficiency not having the time component into their calculations. The third method-Internal Rate of Return IRR uses this fact and introduces us into time dimension of each investment undertaking and presents a step further into our thinking. The time can be presented on the graph below where the firm and investors have the choice now to involve themselves in the activity of foregone consumption now and investing and the increasing the consumption in the future. Marginal return to investment is the slope of the Physical Investment line and is presented as the concave curve on the graph below.

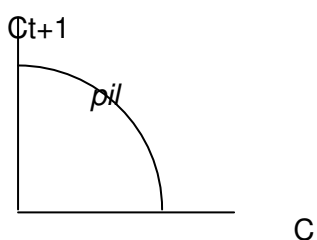

The rate at which the current consumption is sacrifice for the future is $(1+R)$ and is the marginal rate of return on investment.

Investors have different preferences or tastes for consumption that can be drawn as convex curve and presents bundles of goods for which investors are indifferent. It is the time preference of money $-(1+p)$.

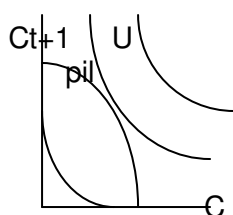

We shall allocate our resources where the marginal rate of return on investment equals the marginal rate of substitution $= -(1+p) = -(1+R)$. In the case of no perfect capital markets we equalise the $p=R$ or undertaking the investment as long as the $p < R$ marginal return on investment is bigger than rate of time preference.

Introducing the third line straight one with the slope $-(1+r)$ market opportunity line we are presenting the decision among consumption now and in the one years time with the borrowing amount on the rate r on the capital market or lending the amount now and consume it later.

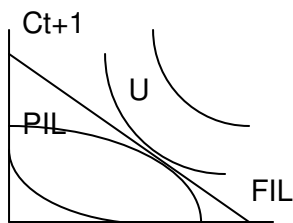

C

Investors will borrow the money on the market at the rate $-r$ as long as the $R > r$ or return on investment bigger than the borrowing rate. In the opposite case he will lend the money. The equilibrium is reached when $r = R = p$.

In order to maximise the welfare the owner borrows or lend on the capital market and their decision to invest is different from the managers what is known as the Separation theorem. On the graph is presented three possible solution for the owners: he can either reduce the dividends now by lending on the capital market, consume all the dividends now and make no usage of the capital market or increase his current consumption by borrowing on the capital market. In other words speaking the managers make only physical investment and shareholders can use the financial market to satisfy their personal consumption needs.

In this frame comes the discuss about Net Present Value and the Internal Rate of Return which both take into their discussion time value of money.

Net Present Value is calculated as the discounted cash flow at the market interest rate – discount rate minus the initial investment outflow. The graphical interpretation follows:

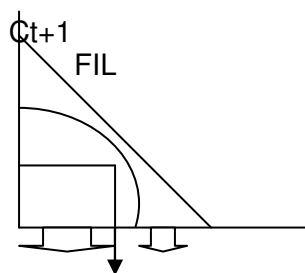

Dividend Invest NPV

The project is accepted if the NPV is greater than zero and rejected if it is less. It is very thorough method which takes in account all the future costs and benefits of certain investment, implement time dimension in the calculation following the fact that dollar in the future worth less than today- all cash inflows and outflows related to the project are included, it gives precise data without ambiguities in the calculation or results. The focus is on the owner's wealth and utility, maximising it what is ultimate goal of having and possessing a certain company. In the case of several projects with the different timing we can compare NPV on the bases of the results found the Uniform Annual Series what different projects clarifies and makes easier for managers to decide. In the case of mutually exclusive projects Profitability Index pointed us toward the right decision and it is result of present value of cash flows of the certain project divided with the initial investment outflow. The result what is obtained is quantified in real financial terms comparing to the IRR what presents the percentage rate of return. Internal rate of return is the rate at which the $NPV=0$ and if the $R>r$ it is useful to undertake the project. Although it is popular among the managers it suffers from some very important deficiencies. Firstly, in the case of mutual exclusive project higher rate of return does not necessarily mean the huger NPV – some project that have a huger IRR can have a smaller NPV and contrary what is presented on the graph below.

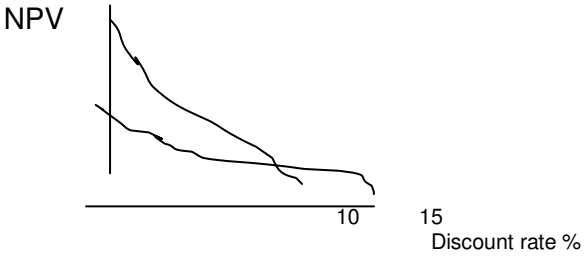

This can be presented at the investment consumption diagram at the two mutually exclusive projects. Wealth is maximised at the point where the higher indifference curve is achieved or at the cut of the Financial Investment Line and the Production one. In the case of two mutually exclusive projects it is not visible using the IRR which project is better to undertake because the Financial line are parallel. It is shown on the graph.

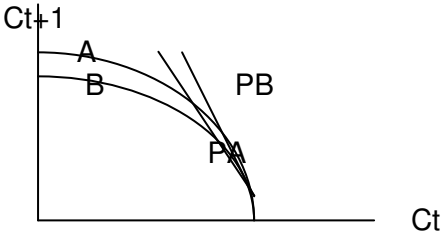

Unknown to the NPV it is problem of multiple IRR or multiple solution and even negative rates. The following big problem that IRR is not answering is the one, which we came across if multiplying the formula with the denominator. $(1+R)$ and further conclude that the cash flow is reinvested at the internal rate instead of the market or opportunity rate.

This are basic deficiencies of the major candidates over NPV and are at the same time depicts the advantages of the NPV.

But we can ask ourselves if this is the best method which we know and we use in our calculations – with the help of computers and software packages-what are the problems that are still present and that can be maybe improve?

Firstly, I would say that the best method is the one that is suitable for the project, manager or undertaker, situation on the ground, impact on various fields: technological, economical, financial, social, political etc. What means that it is not necessarily NPV the one that is suitable for the small range investment decisions?

It starts from the assumption that we need to calculate the future benefits and costs and forgets that sometimes we can run on the serious problems. We can omit some very important benefits which are result of our project –can be social or environmental or have some positive effect on human life's- we are currently undertaking project of making gas infrastructure in the southern and western part of the country. While it has economical reasoning in Istra where it should be connected with the Italy which is not rich with the energy and imports a great deal of electrical one from France –so we are seeing our chance in export- but it does not have economical explanation for making this project in Dalmatic- only the social effect-and the price will be equal through the country. The other side of the medal are costs that are sometimes hard to establish even for the next year and investment project can stretch over ten even more year. We should think in advance about cost that are going to occur, using the same methods for depreciation not for the calculation of the cash flow but for the tax relief on profit .We have to decide whether we are going to use straight or linear depreciation calculate the tax relief on it and than involve the scrap value of on machine at the end of the project as the cash inflow-if we are going to sell it on the market. Accelerated depreciation or double declining depreciation is allowed and tax deductible but there is no scrap value after project is done. We have to have clear accounting rules before starting the investment.

Our horizon should broaden and we should look at the economical and political influence that can occur such as: change in the governments policy toward taxes or tariffs, subsidies, potential inflation or deflation, not just the micro effects but also and macros are important and in some cases can have a significant role in our decisions. Working with future cash

flows means to have information about potential buyers, their financial credibility to get their responsibilities done and not to be involved in the low suits that costs money and the time due to the unpaid receivables.

Financial decisions when raising the capital should be thorough examined-because we are not living in the perfect world neither we don't have a perfect financial market. We can't lend and borrow at the same interest rate, so when thinking about how to raise the capital we have to calculate whether we are going to issue new stokes or have a loan. This loan can have a fix amount of payment but interest could also be calculated as the variable one which depends on the current state of the money market Libor+ percentage.

Although we are having the software packages, which help us in calculating the NPV, we are still facing the variety of data that could be wrongly interpreted. Excellent communication and interaction of different occupation are from the primary importance.

2.3.5.2. Capital reasoning

Real world put us boundaries and obstacles that we are trying to cross using the methods of optimisations and liner programming. These methods, which are very much present in the engineering field as much as in economy, calculate the different positions of our project, recognise the variables we want to minimize or maximise. Of course, usually we want to maximise NPV, minimise the costs and are constrained to the certain revenue, capacity etc.

Formula can be written as

$$\begin{aligned} &\text{maximize} \rightarrow \dots x_1 \text{ NPV}_1 + X_2 \text{ NPV}_2 \dots + X_N \text{ NPV}_n < R \\ &\text{minimize} \rightarrow y_1 c_1 + y_2 c_2 + \dots + y_n c_n \end{aligned}$$

Linear programming finds its purpose not just in capital constraints but also includes variables such as labour or material shortages, what can all increase difficulties in reaching the right result but also costs for undertaking the project.

Problem that I see within this method is that minimizing the cost in the short run can lead us to the long run problems such as: lack of investment in knowledge, research, and open the door to competition that actually developed new products are implement new type of services. It is great deal of time, money and effort used in European energy sector to minimize costs but the results are small comparing to the new investment and new ways of supply of energy (from Russia).

2.3.5.3. Risk and uncertainties

NPV has not succeeded to avoid risk and uncertainties of future events, but we developed some measures to calculate the level of risk in order to avoid failure of our investment projects. In the society where information's, prices, demand and supply of certain goods are changing from hour to hour it is harder to come to conclusions considering the long term decisions. Especially the problem is the bigger the huge is the project such as –building the new HE or nuclear plant - we don't know whether this project will return our capital plus profit and use its capacities as we hoped to be so. We are witnessing the market opening not just for common goods but also for energy. This means we can choose our supplier who offers us a smaller price and our capacity can stay empty and end up with losses.

Methods that are commonly used today to measure the differences in risk are expected NAP, sensitivity analyses and imputing the rate of risk on the discount rate.

a) Expected rate of return attaches different probabilities to the events are going to come and we in scheme have trees of probabilities, events and outcome. Than using econometric analyses we are getting the probabilities of failure or negative value of $NPV < 0$.

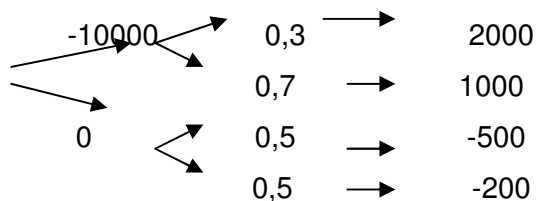

b) Sensitivity analyses are common one of coping with risk where economists item by item approach change one variable to see its effect on the others or with calculating the different level of risk prepare themselves on different solutions. Risk scale is usually set as low, medium and high-risk state of some project. This method seems to me require a lots of work done with the ambiguity in results, demand thorough understanding of some technical problems what is often related to the deficiencies in knowledge by investment economist. The experts have advantage o the other hand knowing the subject but don't know economy. Interaction is of crucial importance in having the good results.

c) The third way of dealing with risk is imputing the risk rate to the discount one when calculating NPV considering different versions of risk. One can use small percentage of incline over the government bonds or in the most cases use the β -market rate of return. It is simple variation, its not time consuming, and demand no extra knowledge of technical nature. A one has to be just good inform and put all the data relevant in the formula.

Investment procedure is process that is interrelated with a lots of different human knowledge's and activities, should be put in the contest of national macro economy, regional market and political situation, market relations: demand and supply of economy, difficulties in finding the costs and benefits related to it, financial, technical environmental contest and value of human lives and quality of living. NPV is the best finger post on our way although it self is not without faults. In today's world it is more and more difficult to make a good decision due to the big market race and uncertainties on it. State can regulate some important investment activities in the energy sector and open or deregulate others. In this way we should still be willing to think about investing in production, distribution and not be just passive subjects.

A scheme for investment is following:

| | | | | | | | | |
|-----------------|---------------------|---------------------------------|------------------------|---------------------|--------------------------------|---------------------|-------------|---------------------------|
| Investment plan | NPV-or other method | determine the right information | calculating the result | analyses of results | imputation of risk in analyses | environmental risks | human value | decision about investment |
|-----------------|---------------------|---------------------------------|------------------------|---------------------|--------------------------------|---------------------|-------------|---------------------------|

2.3.6. Macroeconomic influence

To what extend macro economy influences companies performance should be clearly stated and carefully followed. Inflationary economy demand different way of thinking and decision processes than in deflationary economy. This could bring company to make changes in investment policy or to rethink storage procedure (LIFO , FIFO, etc).

Oil prices could have significant impact on level of costs and regression analyses need to be undertaken.

Having a task of undertaking an investment decision in deflationary economy I first start to think about real economic situation where prices are falling. I realize that it is not just Croatia that usually copes with diagrammatically opposite problem such as having inflation or unemployment but even the economic giants experience just two short period of falling prices after the Second World War. Every lands macroeconomic policy has measures that are very effective or useful stabilization policies to prevent price falling. When considering the investment in the inflationary environment we have to adjust our nominal discount rate for the inflation factor to obtain the real discount rate, which is suitable for our analyses. This can be put into formula as $R = (1+r) / (1+i) - 1$ Inflation factor or rise in the prices have a positive sign while the deflation uses negative mark and can be written as:

$$R = (1+r) / (1-d) - 1.$$

Depending upon purpose and aim of our project we are comparing the different measures of deflation. The most widely used for the general purpose in economy are: GDP –which

presents the measure of all the goods and services produced in one country. With comparing the value of GDP in current year with the previous year or in the case of calculating the index we are marking a base year as 100 and comparing it with the current year. Others indexes that are the mostly present in our calculations are PCE, CPI, CPI-U and PPI and which one is actually implemented depends upon our purpose. Derived from the GDP is the second measure of the deflation: PCI or Personal Consumption Expenditures –measure of change in prices of goods and services purchased by individuals. Different ratio of prices that are determined in the consumer basket makes another group of index related to the change in prices: Consumer Price Index or CPI. This index can be related to the different groups of people such as CPI-U for urban population, or CPI-W for the wage earners and exclude the unemployed population and professionals. This index can be used in analyses that are related to the local or state matters. The third measure is often used in industry and is related to it as the name suggest: Producer Price Indexes PPI. It is good measure for different productions, commodities or industrial sectors.

The data relevant for our calculations can be found in statistic departments, different ministries, institutes that collect information for each year and cover almost every area of human activities. Although there are not perfect index I would use one that is relevant to my subject of interest.

As I suggested earlier when doing investment calculations by using the NPV we often should join different risk rates or conduct sensitivity analyses. While inflationary economy is the high risk one, the deflationary one on contrary, has a low level of risk and make our project safer. It is present in the East Asia and can be explained by contraction aggregate demand side of economy. If we draw a diagram we can see the demand and supply side of economy.

Moving D to D1 we are getting the price smaller and that can be achieved by moving the LM curve or IS curve to the left, or with active government decisions. Monetary side LM tells us that prices are positively related to the quantity of money or $P = k \cdot M$ or $MV = PQ$ On the fiscal side can be reduction in production, or export decreasing.

It is rare that some economy has this situation and I would concentrate myself on the further steps of government to see long term trend .

2.3.7. Market analyses

The strategic planning process for a business begins with trying to obtain answers to three simple questions: Where are we now? Where do we want to be? How are we going to get there? The first question is usually answered through the use of SWOT analysis. SWOT is acronym standing for Strengths, Weaknesses, Opportunities and Threats. It provides a useful framework for analyzing a companies existing situation, both in terms of its own strengths and weaknesses and in terms of the opportunities and threats posed by the external environment within which it operates. To undertake SWOT analyses the company first undergoes a self-critical review of its existing strengths and weaknesses. In doing so it looks at its existing product range; its fixed asset base; its human resources and it looks at its existing producing range; its fixed asset base; its human resources and its managerial capability. This inward look is then followed by an outward look at its operating environment. In looking at both the opportunities and the threats that it may face the company would examine such issues as changes in consumer demand for the companies products and services; the range of competitors that the company faces in the market place and the way in which technological change is affecting the company its products and its organization.

Once the company feels it has a clear response to the first question it can then turn to the second related question: "Where do we want to be in three to five years time?" According to Porter there are five key factors, which determine how attractive an area of business will be to a company: buyer power, supplier power, entry opportunities, substitute possibilities and competitor rivalry. These competitive forces are termed profit or value drivers and it is these that the company must take into account in answering the question where we want to be? In terms of what business areas should we expand into? What business areas should we withdraw from? And how can we improve a business areas level of profitability?

SWOT (strengths –weaknesses- opportunities- treats) analysis should be made not just once in the life time of one company's life but at least yearly. How often is the re valued depends upon status on the market whether or not is monopolist what is still rarely or works in the more competitive oligopoly market?

After making SWOT analyses competitive surrounding should be valued in order to reach conclusion about their costs, profits, planned or current production, installed capacity, future investment opportunities and chances.

10 7 1 Strengths

10 7 2 Weaknesses

10 7 3 Opportunities

10 7 4 Treats

10 7 5 Competitive surroundings

10 7 5 1 Number of competitors

10 7 5 2 Capacity

10 7 5 3 Competitive costs/revenues

2.3.8. Creativity

Even Balzac thought us that success is fruit of hard labour or strong genius impulse.

This connects us to the creativity topic and its importance. While Western economies are seeing as creative ones, balance was made on the Asian production side while making the cheap already seeing products on the market. This newly balance is justice made by nature and forcing richer western countries not to sleep but to use their wealth in order to create something new, useful, energy efficient, more productive, or simply beautiful. Having more money better research facilities more organized and richer economies obliged them to invest in innovation and research and establish the balance while letting the poor Asian countries to enter into world corporate worlds with cheap similar products.

If we all fail to develop our creative strengths world would soon be filled with dust, environmentally damaged materials and gases, tons of un recycled products, energy crises due to lack of clean technologies and many toys. Creative strengths could be found and incentives in each company, no matter how large or small it is, while the good ideas are often found in small ones. No matter how repetitive or boring one job is an employer should leave some extra free time to employee in order to think about new ideas or make this job on more productive way. This time should not be seen as the vase one but as collection and reaching the new ideas and knowledge's while trying to do the same thing on different way.

The direction should be established between corporate and research centres and talented student who lack the proper means. Reality today is work among various groups, with

various acknowledges and experience in order to achieve more qualitative products and services.

The accounts that could be considered under this chapter are:

- 18 1 1 New products
- 18 1 2 New services
- 18 1 3 New technologies
- 18 1 4 Environmental handling
- 18 1 5 Energy saving
- 18 1 6 Advertisement, media, communication
 - 18 1 6 1 Film, radio, pictures, slogans
 - 18 1 6 2 Ads, sports,

2.3.9. News, press, information, public judgements

News and press models our daily life and business performance is often under scrutiny of public eyes. Is the public more or less open to some changes or more conservative in their views is often consequences of the media influence. Ignoring its power would be disadvantageous and the right battle and strategy should be made and followed. It doesn't necessarily implies that constant public appearance can give benefits to company –on contrary it can harm it and endanger long term prospects. Public appearance should be made only if product is made, company is ready to challenge any potential critics and all public statement, reports and behaviour of company's representative should be verified and clearly stated. Public is subordinated toward partial and incorrect statements that could lead to minimisation of companies good achievements.

Although good public relation or bad image is in the most cases difficult to judge and value some factors such as stock price rise / fall, stocks quantities bought/sold, opinion pools, number of un /favourable articles or TV reports etc.

Accounts that need to be followed are:

- 19 1 Media (+,-)
- 19 1 1 TV
- 19 1 2 Newspapers
- 19 1 3 Ads
- 19 1 4 Public opinion

2.3.10 Indirect elements allocation

This qualitative part of reports need to have in certain if not all cases size to balance the qualitative description of companies activities. This can be done in the following ways:

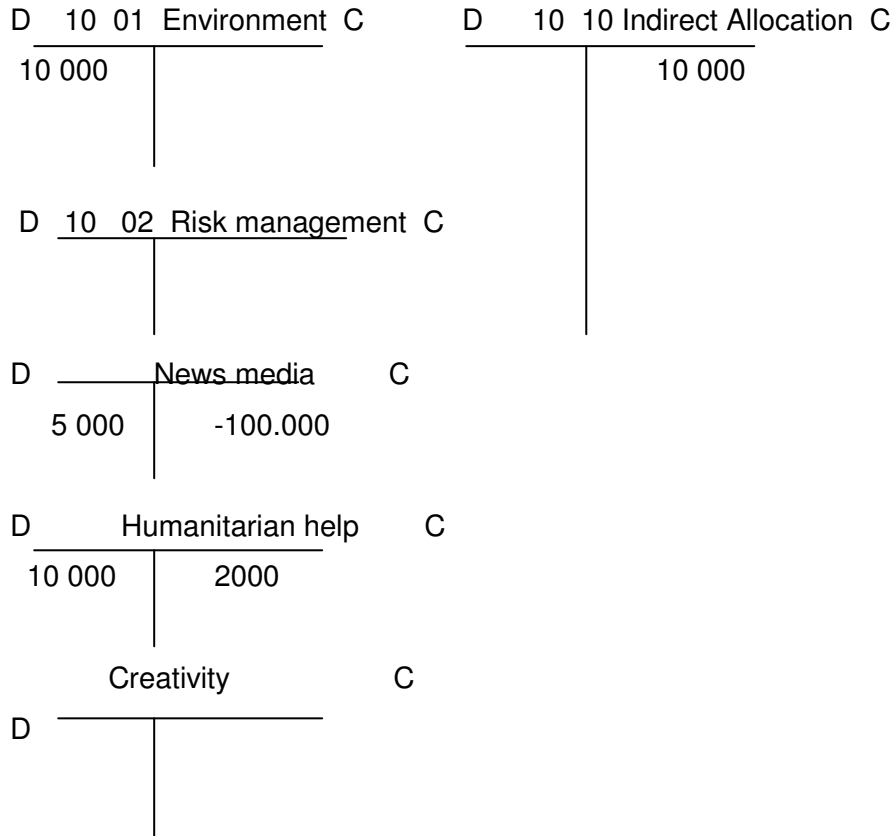

2.3.11. Company mark with indirect effect

At the end all indirect effects are summed and transferred to indirect mark account that gives us the clue how secondary companies effects are develops. It can be signed up as

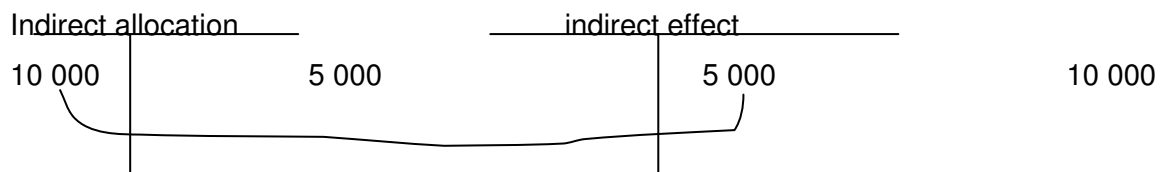

2.4. SPACE DESCRIPTION

Company doesn't flows in the sea of standards and rules. Even if framed in good time space consideration is also relevant. Although very distinctive types of European and Anglo-Saxon rules doesn't imply opposite business logic. We have to admit that privatisation process in various transition countries goes with more or less success, bribery is a normal way of making business in great parts of Africa, Asia and Eastern Europe, business behaviours in some countries include women and other not, military strength can provide some nice perspective for "bad" companies and disclosures of certain successes. Write framework depends upon country where the first step would be econometric measures of following variables: GDP, GDP/capita, Investments, Population, Consumption, Inflation, Bankruptcies number, Bribery, War variable, Transition economy, etc.

Theses consideration leads us to put out quality cube into right position in space framework.

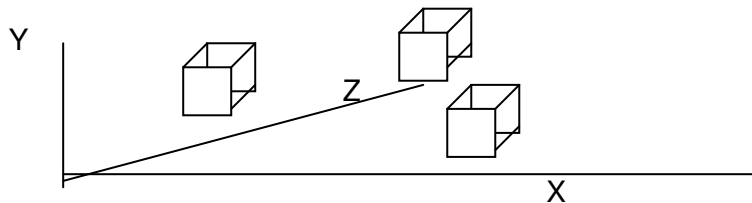

Very static company with limited opportunity of expanding would take the form of ellipse, while continues merge ring would bring us to logarithmic spiral.

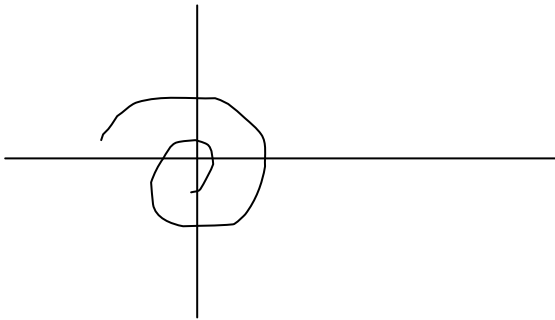
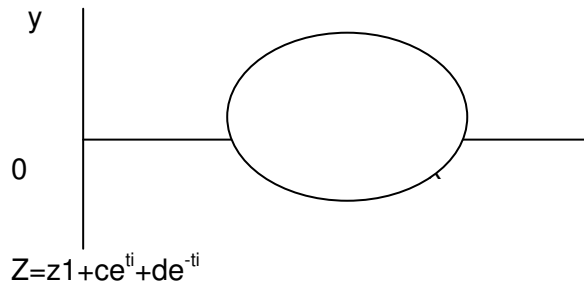

$Z = ae^{bt}$ where a and b depend upon space coordinates of company.

Accounts connected with the subject could go as follows:

- 21 General spatial determinants
- 22 Risks
- 23 System change
- 24 Ethics
- 25 Uncertainties

2.4.1. General spatial determinants

Company's performance and its status are often related to the physical place of headquarters or place where it operates. It is often heard on economist's sessions that bribery or nepotism causes great deal of concern when trying to widen its business operating in developing countries. Numerous stimulants could be offered such as tax relief's, subsidies or good geo position if inflexible un transparent government follows it and business surroundings that understand only language of money and arms a little can be achieved.

General spatial determinants should be carefully determined especially if it is a word about global corporation that has to monitor huge number of filial and factories.

When looking at the graph that shows GNP/capita how huge the difference between the Luxembourg and Somalia are is clearly stated.

Although each company should determine its own mayor global spatial factors I am going to point out some important features that companies are meeting. These features starches from

the basic fiscal and government numbers, which could be the first signs of business distortions and in the other sectors. Unemployment in each state of our business conduct could direct us toward possible reduction or increase in our service goods sale or in making the different best contract for each place differently. An average person in Bangladesh would be happy with an insignificantly lower level of salary that on in Great Britain. Un favourable macroeconomic situation as well as mentality or tradition that are visible through bribery could be another factor that causes distortions on the market. Excellent project could fail due to unclear and vague communication standards. Global companies are due to their desire to stretch or cut costs have to produce in the developing countries what means that they should bring them the culture of good communication, fast pace and correct way of doing business and careful monitoring of all activities. Due to economic and social underdevelopment workers in those countries tend to distort information by using the political or working power in order to reach certain money or status benefits.

A small number of countries are living on an Ireland –we all more or less cooperate with each other and each new moment brings us new partnership, membership, allies or foes. If such membership brings certain responsibilities, employment of financial or military means company has to be aware of certain costs / benefits that are not recognizable in the times it has started its operation.

Factors are short listed as:

21 1 Macroeconomic factors

21 1 1 1 Fiscal

21 1 1 2 Government

21 1 1 3 Unemployment

21 1 1 4 Bribery

21 1 2 Communication

21 1 2 1 Clear honest contract based communication

21 2 2 2 Propensity to distort the facts and work in own interest

21 2 2 3 Lack of basic /good business manners

21 1 3 Transitional period

21 1 4 Membership in international organisation

2.4.2. Legislative rules and different accounting standards

The majority of annual reports of large conglomerates that work internationally comprise differences between standards of reporting. They stress the difference between the American or British GAAP, and IFRS, which is employed in the European countries. Having the access to these differences in each moment makes companies equipped with additional knowledge sources in times of making quick decisions where to invest, or is it wisely to

reduce production in certain world parts that are covered with different standards. Detailed knowledge with the computer assistance is from the vital importance to all companies that are subject to different regulation. To make just once a year summary of different method sometimes is not enough and could brought of losing some of the market advantages.

- 22 1 1 GAAP
- 22 1 2 FRSB
- 22 1 3 IAS
- 22 1 4 GAAP /UK

The most prominent differences are stated in the Table4:

| Table 4 : Difference between IFRS and US GAAP | | |
|--|---|---|
| | IFRS | US GAAP |
| Expense recognition | | |
| Employee share Compensation | Recognise expense for services acquired | Two alternative methods for determining cost: intrinsic value market price at measurement date less any employee contribution or exercise price) or fair value at issue using option pricing model |
| Termination Benefits | Account for post-retirement benefits as pensions. Requirements also exist for termination benefits arising from redundancies and other post employment and long-term employee benefits. Account for termination indemnity plans as pensions. | Similar to IFRS for post retirement benefits. More detailed guidance given for termination benefits. Termination indemnity accounted for as pension plans and calculated as either the vested benefit obligation or the actuarial present value of the vested benefits. |
| Assets | | |
| Internally generated intangible assets | Expense research costs as incurred. Capitalise and amortise development costs only if stringent criteria are met. | Expense both research and development costs as incurred. Some software and website developments costs must be capitalised. |
| Property, plant an equipment | Use historical cost or revalue amounts. Regular valuations of entire classes of assets are required when revaluating option is chosen | Revaluation into permitted |
| Impairment of assets | If impairment indicated write down assets to higher or fair value less costs to sell and value in use based on discounted cash flows. If no loss arises reconsider useful lives of those assets. Reversal of losses permitted in certain circumstances. Impairment in assessed on undiscounted cash flows for assets to be held and | For assets held for disposal, impairment is based on lower of carrying amount and fair value less cost to sell. |

| | | |
|--|--|---|
| | used. If less than carrying amount, measure impairment loss using market value or discounted cash flows. Reversal of losses prohibited. | |
| Inventories | Carry at lower of cost and net realisable value. Use FIFO or weighted average method to determine cost. LIFO prohibited. Reversal is required for subsequent increase in value of previous write-downs. | Similar to IFRS, LIFO permitted. Reversal of Write down prohibited. |
| Derecognising of fin. Assets Measurement | Derecognise financial assets based on risks and rewards first; control is secondary rest | Derecognise based on control. Requires legal isolation of assets even in bankruptcy. |
| Liability | | |
| Provisions general | Record the provisions relating to present obligations from past events if outflow of resources is probable and can be reliably estimated | Similar to IFRS; with rules for specific situations (employee termination costs; environmental liability, loss contingencies etc) |
| Provisions-restructuring | Recognise restructuring provisions if detailed formal plan announced or implementation effectively begun | Recognition of a liability based solely on commitment to a plan is prohibited. Must meet the definition of a liability including certain criteria regarding the likelihood that no changes will be made to the plan or that the plan will be withdrawn. |
| Leases –lessee accounting; sale and leaseback transactions | For finance lease defer and amortise profit arising on sale and finance leaseback. If an operating lease arises profit recognition depends on sale proceeds compared to fair value of the assets. Consider substance/linkage of the transactions | Timing of profit and loss recognition depends on whether seller relinquishes substantially all or a minor part of the use of the asset. Immediately recognise losses. Consider specific strict criteria if a property transactions. |
| Financial liabilities classification | Classify capital instruments depending on substance of the issuer's obligations. Mandatory redeemable preference shares classified as liabilities. | Where an instrument is not a share, classify as liability when obligation to transfer economic benefits exists. |
| Convertible debt | Account for convertible debt on split basis, allocation proceeds between equity and debt. | Convertible debt is usually recognised as a liability. |
| Equity instruments | | |
| Capital instruments-purchase of own shares | Show as deduction from equity | Similar to IFRS |
| Derivatives and hedging | | |
| Derivatives and other fin. Instruments | Measure derivatives and hedge instruments at fair value; recognise changes in fair value in income statement except for effective cash flow hedges Gains/losses on hedges of foreign | Similar to IFRS except no basis adjustment on cash flow hedges of forecast transactions. |

| | | |
|--|--|--|
| | entity investments are recognised in equity, including hedge ineffectiveness on non-derivatives. | |
| Other accounting and reporting topics | | |
| Functional currency determination | If indicators are mixed and functional currency is not obvious, use judgments | Similar to IFRS; no specific hierarchy of Factors to consider. Generally the currency in which the majority of revenues and expenses are settled. |
| Hyperinflationary economy | Entities that have as functional currency the currency of a hyperinflationary economy must use it for measuring transactions. Remeasurement of the measurement unit at the balance sheet date is required. | Denote permit inflation adjusted financial statements ;instead requires the use of a more stable currency as functional currency |
| Segment reporting-scope and basis of formats | Public entities; report primary and secondary segments based on risks and returns and internal reporting structure | Public entities; report based on operating segments. |
| Segment reporting accounting policies | Use group accounting policies | Use internal fin. Reporting policies |
| Interim fin. Reporting | Not mandatory to prepare interim statements but must use the standard if prepared. Basis should be consistent with full year statements and include comparatives | If issued, the contents of interim statements are prescribed and basis must be consistent with full year statements. |
| Insurance and reinsurance contracts | Provides definition of insurance contracts. Subject to few minimum requirements | No single definition. Detailed measurement basis for the different types of insurance contracts. |
| Separate accounts | Single line presentation not permitted | FAS60 and SOP 03-1 allow single line presentation in the balance sheet and offsetting of investment results with changes in policyholder liabilities in the income statement |

2.4.3. System change

Transfer from one economical and political system to other causes at regular a great stress, lot of additional world and greater possibility of failure. Includes legal, business, social and changes that varies from the small to great impact on business conduct.

The first significant system change was transition from the socialist to capitalist economies, which has for its consequences large structural changes, many bankruptcies, and newly established market rules were about to learn quickly. Without clearly stated where we are and where we are going too proper valuation and business aim would not be reached.

The second significant system change was transfer from national currencies to one unifying volute Euro in countries of European Union.

The accounts related are

- 23 1 1 The first system –
- 23 1 2 The second system
- 23 1 3 Aims to be reached
- 23 1 4 Legislative impact on business conduct
- 23 1 5 Revaluation
 - 23 1 5 1 Assets
 - 23 1 5 2 Immaterial assets
 - 23 1 5 3 Capital

2.4.4. Ethics

Ethics in the business world is often just the phrase behind all interested parties seeing only profit. That these times are behind us shows us some capitalist companies that from year to year impose some ethical and moral standards in the way they conduct business, communicate inside and outside company, are present and willing to help voluntarily creating the climate of connection with environment they are living. Even profits amounts are coming under lenses of ethical business while being pressured to share its capital with underprivileged ones.

There would be good praxes to establish a set of key ethical components like contribution to society, employee volunteering, marketing ethics and environmental ethics.

Company is expected to comply with all laws, regulations and code of marketing praxes. By following Code of Business Conduct company is obliged to not knowingly creation of work which contains statements suggestions or images offensive to general public decency and will give appropriate consideration to the impact of our work on minority segments of the population, either that minority or by race, religion, national origin, colour, sex, sexual orientation, age or disability.

One of the good measures to follow company's success is number of complaints on their businesses and way of handling all disputable situations.

The problem with this point is it is quite new to majority of managers / workers while their current / future success is closely related with lack of ethical standards but involving it in our daily accounting reports this would force them to change their perspectives.

Ethical standards inside corporation has the important long term strategy of making community of having the employees that could count of certain rules and be sure that good manners are not an obstacle. Keeping privacy of workers and customers having honest relationship with all directly and indirectly involved insures company's long-term success.

In relation to the community where corporation doing business, voluntary work should be normal praxes and workers should at least one day a year (not to be punished like salary deduction) be part life of community in the way to offered pro bono work. Company should encourage employee volunteering because its benefits the charity and people. Pro bono work should be classified by category and followed in percentages (health, local community, other, education, art, environment, illegal drugs, alcohol abuse etc)

Under this category employee ownership plan as well as care for the health and communication also could very easily fit. Not rewarding the good employees in the case of profitable company creates significant damage in it good name and is unjust toward employee, not protecting the employee in the times of need, or lacking the consideration about childcare, training on stress, time management are also facts that creates huge discourse among involved parties. Communication could be disrupted if one of the following factors are not met: distribution of the Annual Report inside the company and among all companies worldwide, a monthly online news bulletin e-wire is not seeing as important, regular communications on Group initiatives and professional development workshops are not attended, formal and informal meetings at operating level are not kept.

These categories could be seeing as accounts:

- 10 4 Ethics
 - 10 4 1 Business Code
 - 10 4 2 Marketing ethics
 - 10 4 3 Social marketing
 - 10 4 3 Workers
 - 10 4 3 1 Diversity
 - 10 4 3 2 Development and training
 - 10 4 3 3 Employee ownership
 - 10 4 4 Communication
 - 10 4 4 5 Health and well being
 - 10 4 5 Social investment
 - 10 4 5 1 Pro bono work (categories)
 - 10 4 6 Environmental supply chain
 - 10 4 7 Employee harassment and discrimination

2.4.5. Uncertainties

Decisions and companies business is made in the uncertain environment. Uncertainties arise because the consequence of a decision is seen not to be single sure outcome but rather a number of possible outcomes. There may be technological uncertainties whereby the firm may not be able to predict with certainty the output level, which would result from a given set of input quantities. This may arise for example from the possibility of variations of exogenous variables which effect the outcome but which are outside the firm's control e.g. weather conditions. There may be market uncertainty; a single household or firm may not be able to predict with certainty the market prices at which it will buy or sell though it has to take decisions in advance of acquiring this information. This uncertainty will be very much associated with disequilibria and change if an economy were permanently in long run static equilibrium then firms and households would expect to trade at equilibrium prices which by experience become known. If however changes are taking place through time which change equilibrium positions the individual agents in the market cannot know the new equilibrium in advance and can only from expectations of prices which they know may be wrong. Three kinds of variables play part in an economic system, The first one is the choice variable of the decision taker, those variables those variables whose values are directly under his control Such variables are not only endogenous to the model of the economic system but are also endogenous to the model of the individual economic agent. The second variables are those whose values are determined by the operation of the economic system by the choices of individual economic they regard agents and which as parameters. In competitive economy prices are such determined variables. These variables are endogenous to the model of the economic system but exogenous to the model of individual economic Agent. Environmental variables whose values are determined by some mechanism outside the economic system and which can be regarded as parameters of the economic system. They influence its outcome but are not in turn affected by it. Theoretical framework to deal with formation of plans and expectations and their influence on current choices.

Before we start to analyse possible uncertainties it is establish state of the world which is actually a vector of n possible states or Cartesian product of $S = (s_1 \times \dots \times s_n)$. This set can be exhaustive in that it contains all the states of the world which could possibly happen in period 2. There is possibility that members of the set are mutually exclusive in that the occurrence of any one rules out the occurrence of any other. The third possible case is that the states of the world are outside the control of any decision taker so that the occurrence of any one of

them cannot be influenced by the choice of any economic agent, or indeed by any coalition of agents.

Question that is asked to be answered is to find optimal choice under uncertainty. First we should define the object of choice and then we can consider the question of the decision takers preference ordering over these choice objects. Our representative individual assigns a probability P to state of the world s and we denote the vector of these probabilities by $P = (P_1, \dots, P_n)$ while $y = (y_1 \dots y_n)$ in the corresponding vector of state distributed incomes. Then we define prospect P as a given income vector with an associated probability vector. $P = (P, y)$ It is possible to define a new prospect by changing the probability vector P or the income vector y or both. Another term for a prospect would be a probability distribution of incomes or prospect. Any decision has as its only and entire consequence some prospect P and choice between alternative actions or decisions is equivalent to choice between alternative prospects and a preference ordering over decisions can only be derived from a preference ordering over their associated prospects. The object of choice consists of a set of prospects, which we can denote by $(p_1, p_2 \dots p_n)$.

The decision taker if faced with any two prospects says she prefers one or another or is indifferent between them. It is also worth noting that the decision taker would always prefer a standard prospect which gives the better chance of getting the higher valued outcome while two standard prospects with the same chance of getting the better outcome would be regarded as equivalent.

If the decision taker does indeed rationally evaluate the probabilities of ultimately obtaining the two outcomes and is not affected by the two-stage nature of the gamble and can say he does not suffer from risk illusion. This statements on the other hand suffers or incorporates a strong assumption about the rationality and computational ability of the individual decision - taker.

Each decision maker wants to maximise his utility which is defined relative to the values of y_u and y_l and bounded by the value 1 and below by the value 0. For the analyses sake it is useful if the utility function is differentiable at least twice in its entire domain that is if the derivatives $v'(y)$ and $v''(y)$ exist for all y in the interval $[y_u, y_l]$. The first difference $v'(y)$ is the marginal utility of income and $v''(y)$ is the rate at which marginal utility of income changes with income. If the prospect is written as $P = (P, y_1, y_2)$ the expected value of the outcomes is then $y = py_1 + (1-p)y_2$. Certainty income of prospect P can be seeing as $y(y_c) = v = P * v(y_1) + (1-P) * v(y_2)$ That is $-y_c$ is the amount of income which if received for certain would be regarded by the decision taker as just as good as the prospect P .

There are three possible cases between the relation between certainty equivalent y_c and the expected value of the outcomes. If $y_c = y$ the decision taker values the prospect at its expected value. If the $y_c < y$ the decision taker values the prospects at less than its expected value. In this case a preference ordering over alternative prospects could not be based on

expected values of outcomes, since these overstate the values of the prospects. To predict the rankings utility function or certainty equivalents should be familiar.

The third case is when the $y_c > y$. Then the decision taker values the prospect at more than its expected value. A preference ordering over prospects could not be based on the expected values of outcomes since these now understate the values of the prospects.

These three ways of classifying attitudes to risk, based on a comparison of the certainty equivalent on the one hand and expected value on the other. The kind of attitude where prospects are valued at their expected values are risk neutral; the second where prospects are valued at less than their expected values risk averse; and the third case risk attracted.

Utilities of risk averse and risk attracted are presented on graphs.

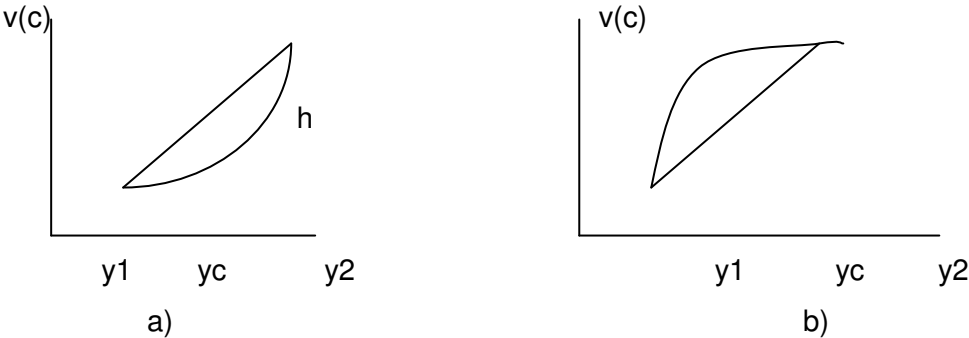

In the figure a) $v(y)$ is strictly convex and y shows the expected value of income for a particular choice of P. The certainty equivalent is $y_c > y$ since $y(y_c) = v$ at h. The risk attraction is equivalently described as corresponding to a strictly convex utility function, or a certainty equivalent in excess of expected value of income.

Figure b) shows us strictly concavity of utility function where $y_c < y$ and suppose assumption of risk aversion.

This can be summed p in table below:

| | Risk aversion | Risk neutrality | Risk preference |
|------------------------------|------------------|-----------------|-----------------|
| Certainty equivalence | $y_c < y$ | $y_c = y$ | $y_c > y$ |
| Risk premium | $r > 0$ | $r = 0$ | $r < 0$ |
| Fair bets | reject | indifferent | accept |
| Utility function | strictly concave | linear | strictly convex |
| | $v'' < 0$ | $v'' = 0$ | $v'' > 0$ |

The risk averse individual will prefer to have a certain income of y rather than the risky prospect $P=(P,y_1,y_2)$ where y is the mean of the risky incomes y_1 and y_2 . The risky prospect is costly to the risk averse individual in that it reduces his expected utility compared with the certain prospect of y . A monetary measure of this cost of risk can be obtained by asking the individual how much of his certain income he would be willing to give up rather than face the risky prospects.

This sum of money r is the risk premium or the cost of risk and is defined by:

$$v(y-r)=Pv(y_1) + (1-P)v(y_2)=v$$

since the individual is indifferent between the risky prospect P with expected income y and the certain income $y-r$. The risk premium r cost of risk r depends on the individual's attitude to risk and the prospect she is confronted with. It will be larger the greater is the risk and the more risk averse the individual.

Riskiness of the decision makers situation is describes with some risk measures. When there are only two states of the world it is possible to describe the amount of risk facing an individual by the absolute or risk facing an individual by the absolute or relative range of incomes: $y_2 - y_1$ or y_2/y_1 . These absolute or relative distances from 45 ° certainty line where $y_1=y_2$ are crude measures of risk in that they ignore the probabilities of the states. When there are more than two states the absolute or relative difference between the largest and smallest state contingent incomes are even more suspect because they take no account of states in which income is less than the maximum and greater than the minimum. The first good measure of risk is variance because it takes account of all the state contingent incomes and their probabilities. Prospects with greater variance yields a greater expected what takes us to reasoning that the use of the variance to measure the riskiness of distributions is valid only if preferences or the set of distributions being compared are restricted so the higher moments of the distribution either do not matter to the decision maker or are determined by mean and variance.

The decision maker's ordering of prospects, which differs only in location and scale parameters, depends on the mean and standard deviation (or mean and variances). Increase in the mean of y increase expected utility:

$$\partial V / \partial \mu = \int v'(u+\sigma z)g(z)dz = Ev'(\mu+\sigma z) > 0$$

since marginal utility is always positive. Less obviously but more importantly increases in the standard deviation reduce expected utility:

$$\begin{aligned} \partial V / \partial \sigma &= \int v'(u+\sigma z)zg(z)dz = Ev'(\mu+\sigma z)z = Ev'(\mu+\sigma z)z + Cov(v'(\mu+\sigma z),z) \\ &= Cov(v'(\mu+\sigma z),z) < 0 \end{aligned}$$

The risk averse individuals choosing among prospects which differ only in scale and location parameters will prefer prospects with smaller standard deviations (or variances) for a given mean.

Firms face two types of uncertainties. There may be technological uncertainty in that the amount of output produced from a given input combinations is uncertain. The output of wheat depends on the weather as well as the amounts of seeds, fertilizer etc. The firm faces market uncertainty if the prices at which it transacts in input or output markets are uncertain. Uncertainty in market prices may arise because of random changes in demand—because of random variations in preferences consumer incomes or the prices of related goods. Much price uncertainty can also be linked to supply randomness and so production uncertainty may lead to market uncertainty. If the output of wheat is affected by the weather –production uncertainty- this will imply an uncertain price of wheat because of the random fluctuations in supply.

A firm produces a good y , which sells at the random market price p . The firm chooses its output before it known what the state of the world (the price p) will be. The revenue is psx and cost of production is $c(x)$ whole B is the other non-random income of the owner. The firm chooses output to maximize

$$V = E_v(y_s) = E_v(psx - c(x) + B)$$

Assuming that the optimal output is positive the choice of x will satisfy the first order condition

$$V_x = E_v'(psx - c(x) + B) \frac{dy}{dx} = 0 \quad E_v'(px - c(x) + B)(p - c'(x)) = 0$$

where $c'(x)$ is marginal cost. The second order condition is

$$V_{xx} = E_v''(psx - c(x) + B)(p - c')^2 - E_v'(px - c(x) + B)c'' < 0$$

When firm faces technological uncertainty its output is determined both by its choice and by random factors over which it has no control.

2.5. TIME VARYING

Classical Accounting doesn't provide us with information about companies time frame: whether it is a report about entrant or incumbent, giant in problems (an analyst got fired when revealed certain Enron's difficulties a year before scandal broke out) or multinational corporation with huge merge ring plans is often in darkness. In order to lighten this side of company history it is necessary to consider entrance of new accounts that would provide us information about that fact.

Numerous empirical evidence shows that demand for some products grows over time until the market reaches its maturity and then falls gradually thereafter. This pattern of product life cycle is incorporated into companies thinking for their forecasting purposes. We have to put into our consideration economic cycle that is currently present in economy and whether or not we are in recession or have economic boom.

If the time is present as $t \in [0, \infty)$ or we consider company entrance in certain type of industry and explore does it influence entrance. Certainly it is not important for monopoly, while in the oligopoly case new product would certainly have different status than entrance in the well established market for certain product.

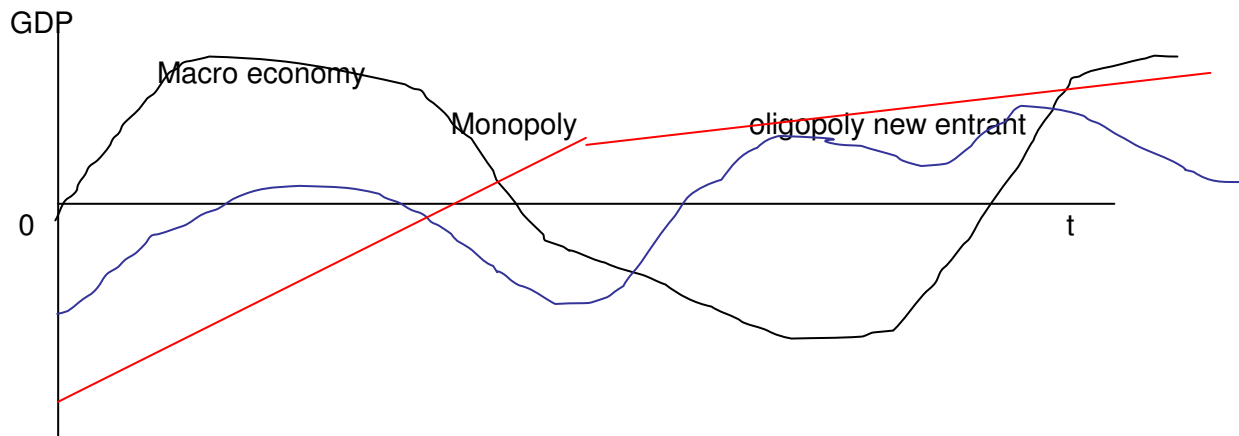

Entry is certainly easier in boom economy for new entrant in oligopolistic market but investment decisions should be based on future economic conditions, strategic interaction between present and potential players, investment costs due to irreversibility of investment and uncertainty about future events. A new comer certainly should consider type of market and if it were a word about small market opportunities entering into new market would be contingent on the duration of the product life cycle. A successful product would attract additional entrants sequentially as the market gradually expands until it began with recession. Very large market, on contrary, would lead firms not to care about the future

evolution of the market. All, those problems are very well hidden in the balance sheets of our business partners. New companies depending whether the percentage reduction in individual profit due to the immediate follower's entry increases or decreases with the number of remaining entrants follow potential entrant.

For the new company which enters into market there are numerous possibilities concerning the investment cost which could be just the buying the existing company (picture a), short research and investment cycle and long period of investment return (picture b), long period of large investments which bring large risks and profits (picture c) or large investment which brings small profit with small risk (picture d).

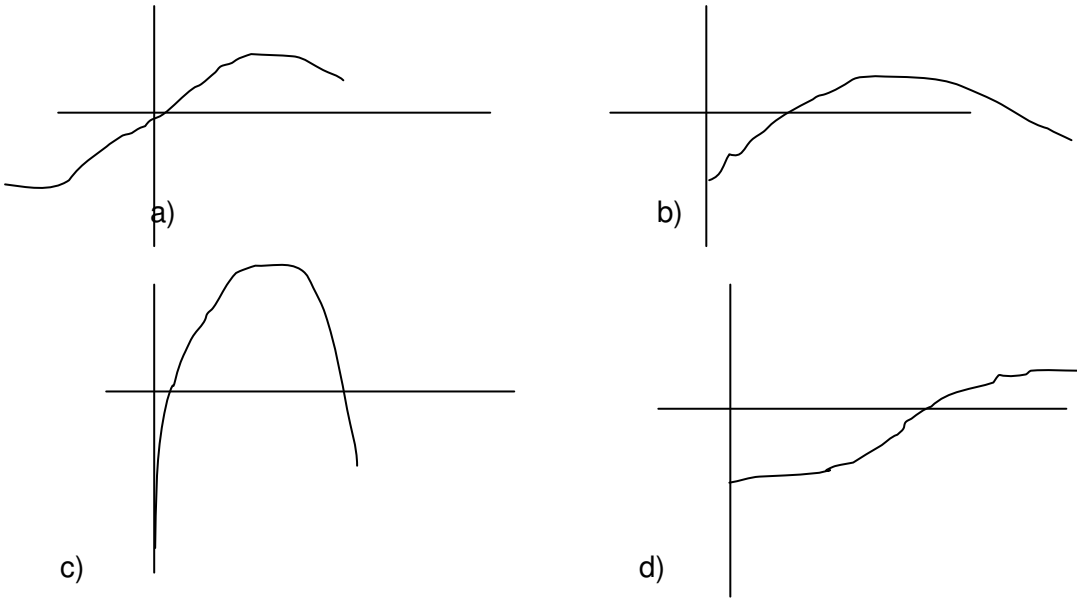

Entrant of new player as well as of new product has the all elements of the game theory non described in accounting books. Risk as well as the phase of company maturity should be visible in reports by including additional accounts.

The reasoning about risk imputation goes as follows:

The first stage balance sheet report:

| Active | Passive |
|------------------|---------|
| Immaterial Asset | Capital |
| Material Asset | Debt |

The second stage involves development of new products (A, B,C) and new services (D,E), together with new experiences, obtained patents and knowledge. This is all present under

one number immaterial asset and investment. How many investments or developments of new projects are going to be or how skilful employees are is not visible while there is no NPV for each investment separately stated as well as hindering of the global market economies.

| Active | Passive |
|-----------------------------|------------------|
| Immaterial Asset | Equity |
| <i>Immaterial Asset</i> | <i>Equity2</i> |
| <i>Afterwards2</i> | Profit a,b,c,d,e |
| Material Asset before | Debt |
| <i>Material Asset added</i> | |

This situation could lead us in period 3 to reveal possible outcomes of which I would write down only two extreme cases. In one scenario there is possibility of total success of all efforts with greater market share, the other leads to failure in all future plans.

| Active | Passive |
|---------------------------|-----------------------|
| Immaterial Assets | Equity |
| <i>New product a ,b,c</i> | <i>Equity a,d</i> |
| <i>New services d,e</i> | <i>Debt c</i> |
| Material Assets | <i>Debt b,e,other</i> |

| Active | Passive |
|------------------|--------------|
| Immaterial Asset | Equity |
| Material Asset | Loss a.b.c.d |
| | Debt |

Lack of knowledge about certain investment, their financing resources and risk as well as type of economy bring to falls market pricing and could mislead future investor.

The risk can be measured and imputed for each investment project and imputed in the additional part of balance sheet based on calculation of internal rate of return and net present value. Additionally, passive side of balance sheet should be burdened with amount of risk that project carries in the beginning faze until it starts selling.

It is the highest risk and at the beginning of the investment project and smallest with getting new markets.

Account 26 =research and development of new project, service, investing,

Account 27= entrance of new product company, service on the market, type of economy through interest rate

Account 28= maturity of product

Account 29= well established market, its share, consideration of merge ring, or decline in sale, market type

Account 30=outcomes of strategy bankruptcy, merge ring, consolidation, result

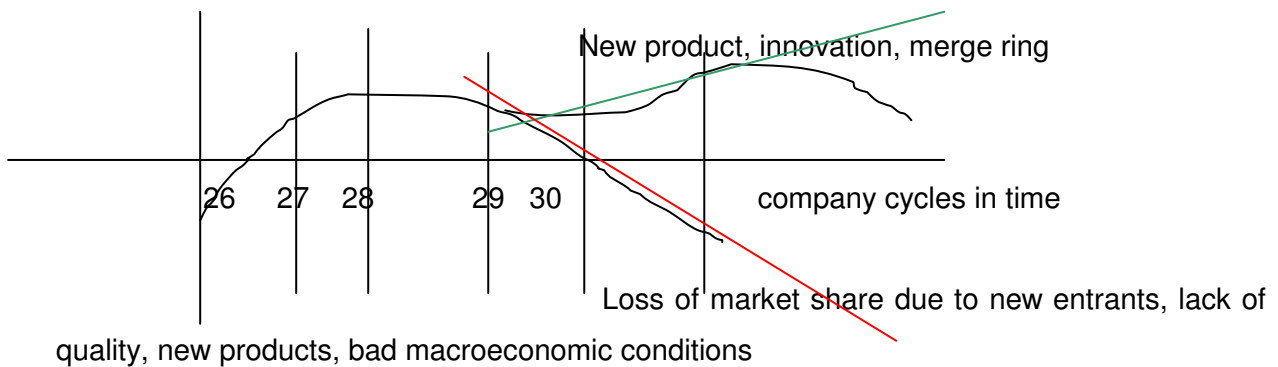

2.6. PROPOSED ACCOUNTING METHODS

Accounting methods proposed by this paper should satisfy basic accounting principles: recognition, matching, objectivity, disclosure materiality as well as output principles: comparability, consistency, uniformity.

Since now, we had basic rules which should be respected and implemented and followed some legal requirements. It is the often case that these rules are avoided due to moral hazard, adverse selection or our bounded rationalities. The Stock exchange have undertaking supplementary role to iron mistakes and quite often prices reacts properly on the negative/ positive movement in direction of one companies. Accounting reports are slow paced, often UN correct and bitten by very dynamic and more and more aggressive stock dominance. We have seen cases of over/under valued stocks due to the speculations on the market in order to buy cheap and sell at the higher price and good and quality companies are often ruined under burden of speculative games.

In order to avoid such scenarios accounting praxes should react more quickly and thoroughly presents all details and relevant information connected to it. This means that some descriptive facts should be given numerical values in order to reach certain and correct conclusions. Accounting praxes should beat the market oversimplification of facts in the way to analyse all good and bad side of the company performance, its surroundings and time line.

Having it done and in each moment ready to be reached by management this wide spectrum accounting reports have more values than information about profit/loss and assets value.

This papers argues that besides 0-9 accounts reports should cover topics such as environmental concern, creativity, human care and rights, good / bad public coverage, education, macroeconomic factors etc the qualitative description what is to be found in the accounts from 10-20. The third part points us toward thinking and analyses of our geographical position and risks and benefits related.

Sometimes, one companies success depends upon companies maturity, whether is it a word about monopolist or incumbent, thorough picture of companies maturity stage, merge ring / acquisition treats/chances and investment possibilities.

When was a word about second part I have placed the basic accounting standards in a big cube to stress significance of the numerical legislative values and the qualitative description was placed as a small cube in its body. It is not hard in the praxes to evaluate some qualitative values and demand knowledgeable person, wide spectrum of information and relevant econometric experience. Although hard task it is achievable with constant education and reliable auditors who do not avoid subjects such as environment and uncertainties. After establishing absolute values of qualitative marks and compare it with the similar companies in the same industry in region and worldwide new horizon's can be reached. It is worth establishing the proper value of the qualitative company body and this value is in the most cases individual. Similarities are the most likely to be in the same industry or region. Although perfect values vary, the best ration between the values and importance of legally established standards and the second part pf accounting reports should be 4 :1. If overvalued qualitative descriptions could lead us toward failure to reach the basic company aim: profit increase.

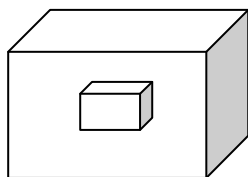

Certain time passage point us toward growth or reduction of qualitative values and are early signals of future profits or losses. Interaction between the two parts should be carefully monitored and followed and sudden rise or change in direction should be immediately analysed and failures prevented.

In the case of lowering qualitative values this could lead to lower educational employee level, having the best people leave the company, or lower environmental standards could cause some legal penalties and environmental pollution or damage.

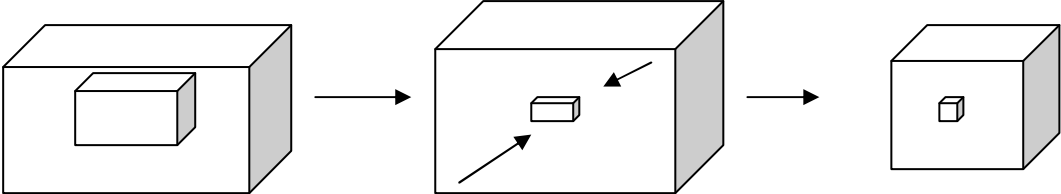

By lacking to admit the importance of qualitative values and ignoring them this values causes the small body of the company its spirit to disappear, with failure to keep qualitative standards possibilities of lower sales, accidents, higher costs, non professional behaviour lead to lower revenue, lower profit, decreasing stock price and possible investors run off. Proper accounting standards could prevent the bad and worse case scenario.

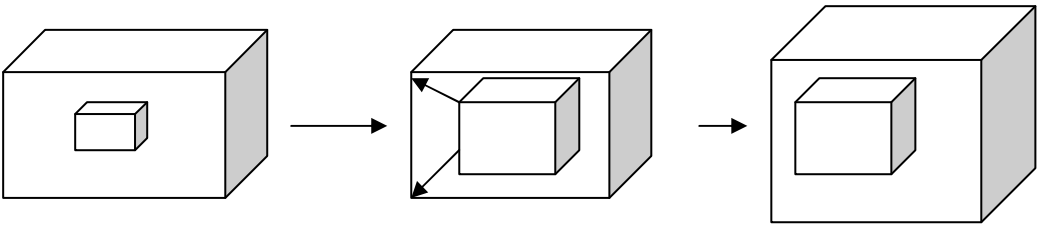

The reverse is valid and case where qualitative reports grows means better educated employees, better market conditions, strong advertising campaigner, and this facts should bring company to the higher level considering revenue, profits and stock prices. If investors confidence grows, company is valued more and have greater chances of new investment opportunities, possible acquisitions etc.

These results would be obtained in the case of normal business and market conditions. Anomalies are possible to happen in the complex business surroundings and should be carefully monitored and analysed. It is the most likely the case with monopolies who do not need to have good marketing campaigner, beneficial market conditions to growth. Sometimes it is the case that very bad market conditions recession or war situation, help some pipeline or water suppliers to growth. It is the case with weapon traders who benefit from uncertainties and bad market conditions. With the profit increase It is possible that companies care less about human rights, education and deviate on making to much advertisement.

Various results after cross sectional analysis would reach results that could help us in establish the pattern of behaviour in different sectors. Quadrate of four could have various shapes from the equal values to minimization of three on account of one part of company performance.

| | |
|---|---|
| A | B |
| C | D |

| | |
|---|---|
| A | B |
| C | D |

| | |
|---|---|
| A | B |
| C | D |

| | |
|---|---|
| A | B |
| C | D |

| | |
|---|---|
| A | B |
| C | D |

After cross sectional analysis is made we could trace whether banking, agriculture, industry, education, military, government and health institutions features the same behaviour across the world.

This analysis could be stretched across time and give us results of various sectors in the following way.

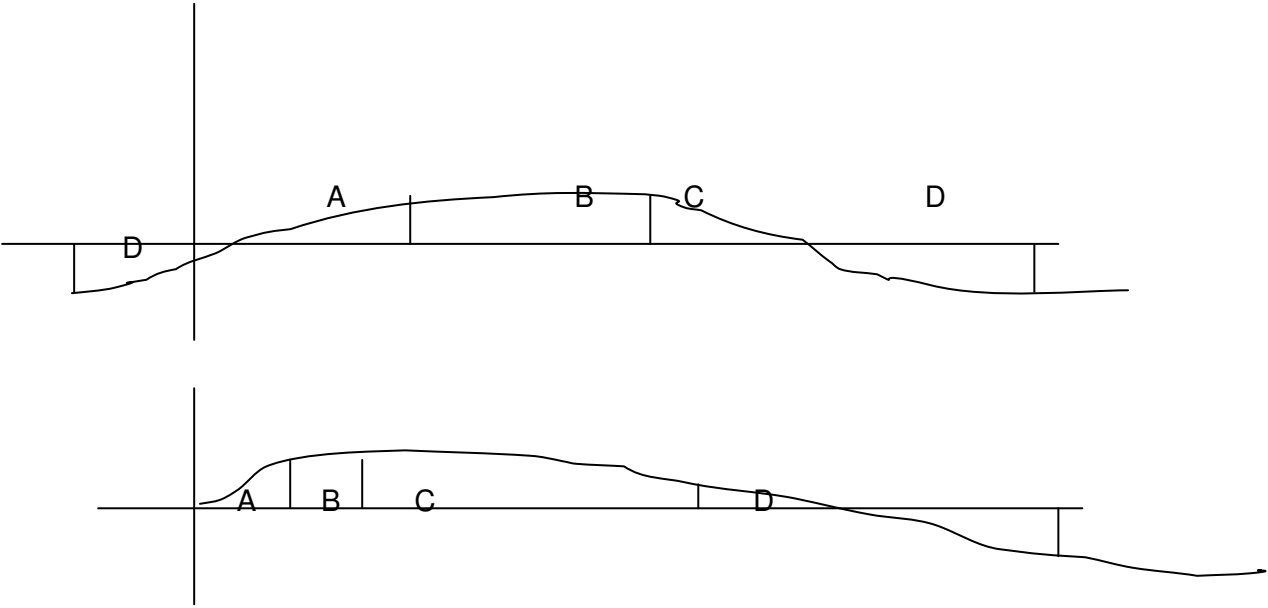

3. EXAMPLES

3.1. WPP

WPP is one of the world's largest communications services groups made up of leading companies in advertising, media investment management, information, insight and consultancy, public relations and public affairs, branding and identity, healthcare communications, direct, promotion and relationship marketing, specialist communications. With 84.000 people working in over 2.000 offices in 106 countries WPP provide communications services to clients worldwide including more than 300 of the Fortune Global; over half of the NASDAQ 100 and over 30 of the Fortune e-50. Distinctive and memorable mission statements confirms their creativity and success: "we exist to develop and manage talent; to apply that talent; thought the world; for the benefits of clients; to do so in partnership; to do so with profit." Having the role as the parent company WPP helps companies in the three distinctive ways: it relieves them of much administrative work; encourages and enables operating companies of different disciplines to work together and finally with a vast geographical spread and all marketing services provided it acts as portal to provide a single point of contact and accountability. Short financial summary gives us the clearer picture about company's performance:

Table 5: Main business measures in WPP

| Description | 2004 | 2003 | Change % |
|--|----------|----------|----------|
| Turnover (billing) | £19.598m | £18.621m | +5.2 |
| Revenue | £4.300m | £4.106m | +4.7 |
| Headline EBITDA* | £ 709m | £ 661m | +7.3 |
| Headline operating profit** | £ 560m | £ 493m | +13.6 |
| Headline diluted earnings per share*** | 32.3p | 29.0p | +11.4 |

* Headline EBITDA: profit on ordinary activities before taxation, net interest payable and similar charges of 70.7 mil. Pounds, depreciation of 103.4mil.pounds, and goodwill amortisation and impairment of 78.5 mil. pounds

** Headline operating profit: operating profit before goodwill amortisation and impairment of subsidiaries of 75.mil.pounds

| | | | |
|-----------------------------------|-----------|-----------|--------|
| Ordinary dividend per share | 7.78p | 6.48p | +20.00 |
| Average net debt | £ 810m | £ 1.222m | -33.7 |
| Market capitalisation at year end | £ 6.792 m | £ 6.513 m | +4.3 |

Excellent financial numbers are presented in spite of recession period and twin deficit in USA, with 39 % of revenue coming from N.America, 17% from UK; 26% from Continental Europe and 18 % in Asia Pacific and other world areas. According the numbers company is more profitable, more liquid, less leveraged and better structured from years to years. Shareowners are by majority seated in UK with 46%, and then in US 39% and only 15 %of them are in other world areas. Very remarkable data is expressed in the following explanatory ownership numbers where institutional investors presents 92% of ownership structure, employee's only 7% and all other players on the market just 1%.

Setting the three priorities: weathered the recession need to build on strong base with a better motivated, incentives and resourced people, with the aim to continue to integrate successfully the acquisition of Young & Rubica Brands and to increase share of revenues of Asia Pacific, Latin America, Africa and Eastern Europe from 20% to 1/3 WPP seems to confidently steps into 21. century.

Very clearly stated objectives in the Annual Report (2004) on which the analysis is based directs me toward opinion that I am ready to comment very successful, know how equipped and extremely creative but at the same time goal oriented company. What can be improved in excellently made and presented with numerous artistic photos annual reporting is going to be made by following WPP six objectives: the first goal is to rise operating margins to the levels of the best performing competition at the achievable level of 15-20%. To continue to increase flexibility in the cost structure and third to improve total shareowner return by maximising the return on investment on the companies 450£ million free cash flow. Fourth to enhance the contribution of the parent company in the way to continue giving added value both to clients and employees. In the way to make as many initiatives as possible, use optimum of property, in information, technology and in procurement and putting all the cards on attracting, making, keeping and educating talents in each sphere of our business life. Fifth objective is stated in words moving up the margin curve greater emphasis on revenue growth is putted and the last but not least although of high quality the aim is to further improve creative output..

*** Headline diluted earnings per share and ADR excludes goodwill amortisation and impairment, fixed asset gains and write downs and net interest charges on defined benefit pension schemes.

Excellent annual report that stretches from the basic answers and explanations about company, examples what they are, why they exist, how they are doing through financial summary, letter to share owners, reports from other operating brands goes beyond narrow companies borders and explain what they think about the global economy and especially the advertising and marketing service industry, Report comprises all answers about who runs WPP and how they behave. Questions like how they are rewarded is answered in detail, operating and financial review as well as 2004 financial statements signed by Deloitte & Touché LLP thoroughly presented and ownership structure as well as basic group information excellently presented.

To start with my hypotheses in order to show another look at the same company I would quote the word of their chairman and Philip Lader and chief executive Sior Martin Sorrell about numbers in the report: those numbers are there because they have to be there –and they are almost universally positive. But numbers disguise the true dynamic of company – dynamic of the people.

My hypothesis goes as follows:

- H0: Yes, numbers can state the dynamics of people
- H1: Yes, we can express ourselves in numbers and be creative
- H2: Yes, new accounting approach would give added value to WPP and explain it more thoroughly than the almost perfect report I have the pleasure to have

Due to simplicity I would obtain all three hypothesis in the following explanation:

Step 1: Draw and explain where we are

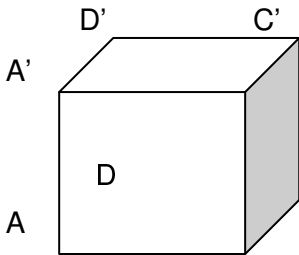

Where letters are chooses from the importance in companies report
 A= assets= B= intangibles= C= Debt= D=capital=
 A'=revenue= B'=Dividend= C'= EBIT= D'=stock price

This picture gives us immediately more insightfully look into importance of some factors in company performance. To give the more facts and describe the companies spirits and real

engine we have to examine the small cube or whatever shape it has what we are determined to discover inside the big one and allocate numbers to them. This how we are going to reach for solution:

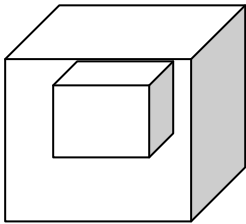

Eight letters that end with the total company performance marks should say something about ecology, risk management, human valuation, project preparation, macroeconomic influence, market share, creativity news, press and connect it with indirect allocation in giving the company total mark.

Huge goodwill amount and almost 89% of intangible assets in the fixed asset structure points us to think that this small cube is very important, huge in its size and should be specially cherish by company.

Letters are allocated after reading the report according the value so:

E=human factor F=macroeconomic influence G=creativity H= News, Press, Advertisement

Of less importance seems to be:

E'=ecology F'=humanitarian help G'=project preparation H'= market share

Company stresses importance of people, their value and creative power their bring to company. It carefully monitors macroeconomic structure of the world and makes forecasting 30 years ahead about major macroeconomic factors for the most significant macroeconomic factors while its revenue is narrowly correlated with boom/slump economic periods; its job is to advertise to be constantly in media and around it for themselves and their clients and how established or newly media branches are developing is of major importance to the companies existence.

Not many words were pointed toward ecology, risk management, and one particular projects, while humanitarian help is recognised and is practiced in praxes through one voluntarily work of all employees and followed statistic about achievements and investments in that area.

Annual report widened by new accounts brought us to the following pictures and conclusions:

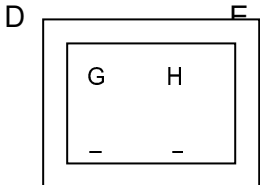

Corners of the balance sheet are tightly depended on Qualitative factors that are not visible in the basic consolidated balance sheet reports and could be

A B eventually discovered /or not by reading 200 pages

of Annual report. While time is indeed money for investors that do not have enough time to study millions of reports short version of wide based studied qualitative factors gives him very quickly answer to question how this company really operates. These are not just boring numbers that need to be there.

The second part of the cube equation consist of profit/loss numbers and qualitative descriptions which are not very broadly elaborated in the annual report due to their minor importance to the real company operation. It could be seeing as follows:

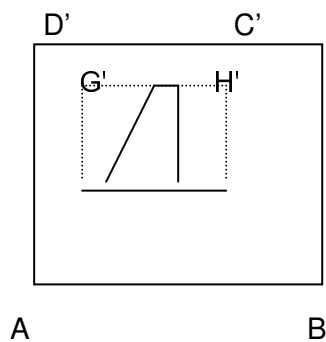

Profit/loss numbers although very depended upon qualitative structure base EFGH , shows less fluctuation . When parameters like ecology or risk management are involved. The only parameter that make “disturbance” to the small square is the humanitarian help that has actually two fold role: help people in community and make an good advertising image in the world. Although we have expected the small cube to have significant effect on the companies performance, its irregular structure rise questions whether factors like ecology, project preparation and risk management are not reported as they should be, are they important to companies operation and to what extent and do they present the natural state of affairs, or need to be more explained. Are these irregularities is source of future revenue or customer’s loss is about to see.

Without recognising it in the annual report we can’t say whether or not this company could follow us in the more complex environmental advertising demands, can manage its own risk and in that way provide good media champagne to financial institution, and is really doing each project separately, originally and carefully like it says it is. My investors would like to be involved in the business that shows him as rabbit in the space chasing some unreachable

star. He should be down earthed with the simplified and at the same time more complicated help of broader accountancy.

Step 2: Allocate the indirect numbers (1-100/100) to each category recognised that qualitatively describes/or not company.

This task requires some speculation and comparison with the other company's numbers. It should be made from the bottom to the top of each category in the following way:

$$y_1 = c + a_1 x_1 + a_2 x_2 + a_3 x_3 + a_4 x_4 + \text{error}$$

where

y_1 = accounts from 10- 18

$x_1 \dots x_n$ qualitative descriptive factors for each category.

For example for

b Y18 = $c + a_1$ * number of adds in TV + a_2 *number of media announcement on radio + a_3 *number of awards getting for advertisement + a_4 *public opinion pools about marketing campaign + a_5 *hours per person per year using consumer media in US + a_6 * top 10 global advertiser + a_7 * worldwide advertising expenditure + a_8 *world's 10 most valuable brands + a_9 *top 100 global marketers spending by category + a_{10} *advertising expenditure as a % of GDP + error

After having all eight equations with relative numbers they are put together in order to form qualitative description relative equation.

Step 3: Put the company in the space

As I mentioned early WPP is not operating in the space without gravity. Businesses are influenced by surroundings and places where the business is conduct. The same type of advertisement would not be appreciated all over the world the same-and the same thing could be praised in one part of the world and prosecuted in the other. Wisely recognised policy and established the place of business and its influence should be stated in each report. Although different accounting rules and their influence on the basic consolidated reports are part of each annual report nowadays, it still stays without spirits hanging that knows where.

To establish this part careful monitoring of the GDP/capita and market share of company should be establish and cube put in write place. While WPP is doing business worldwide with ambition to grow in other world area it should establish its place according to revenue. The graph could look like as follows:

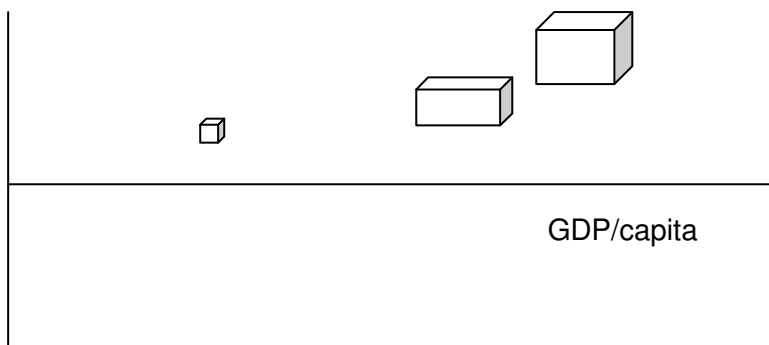

Three cubes presents three different part of world where the company operates. The highest GDP/capita and market share is seeing in the UK with UK GAAP standards employed and projected GDP for 2010 of 1,876 billion \$. The second cube presents US market where significant part of businesses activities is conducted, and part of the world with projected GDP in 2010 of 13 bill \$ but still fighting the twin deficit. The third the smallest cube represents operating in Asia, Africa and Eastern Europe, growing potential market that has for example Russia projected GDP for 2010 of 847 billion \$ a significantly lower GDP and fights with different problems that are currently presently in western capitalist economies.

Step 4: Allocate the real values to the indirect numbers

By making three equations with revenue share ,GDP/capita,GDP, potential growth, uncertainties and risks we could reach the real numbers

$$e Z_n = c + d_1 * GDP + d_2 * GDP/capita + d_3 * market\ shared * revenue + d_5 * turnover + d_6 * risks + d_7 * uncertainties + d_8 * ethics + d_9 * accounting\ differences + error$$

Where Z_n are real number for the three cubes

1 for United Kingdom 2 for United States for America 3 Other Worlds

After this procedure some rough figure would be reached and qualitative value for watch and total inner qualitative cube established.

Step 5: Establish the company's maturity and its future prospects

The step 5 requires that we ones put the company in space deal with the time issue.
Or draw a following diagram.

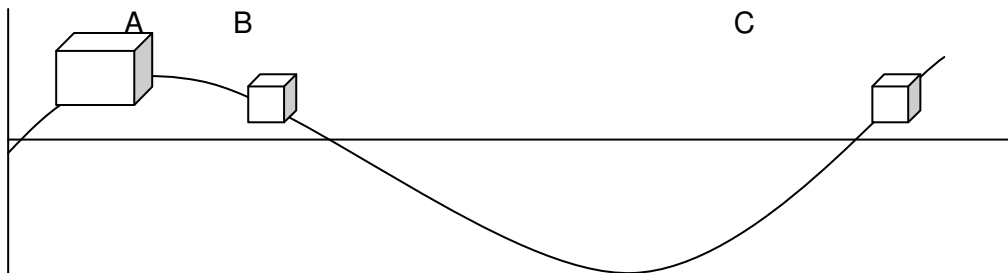

Company WPP is operating on oligopoly market and faces daily with possibility of other companies and competitors to endanger its position what would have for a consequence lost of market. A small cube C presents operation on the other world market but on the line that is rising what means the future good prospects if carefully managed, and future potential growing market share in the world. The cube A brings us some information about mature market position in UK, while cube B possible decreasing market position in USA due to the over saturated market who founds out new informatics' and electronically ways to skip advertisement on TV or internet.

3.2. SCOTTISH POWER

Scottish Power, although registered in Scotland is listed in two hugest world both financial centres because with its business activities provides in excess of 6.7 million electricity or gas services in UK and western US. Operations of electricity generation, transmission, distribution and supply services are offered in both countries it stretches its activities in North America to coal mining, gas storage including gas facilities in western Canada, Texas and New Mexico. The interesting fact about company is it was created upon privatisation in 1991, and then developed by both organic growth and strategic acquisition in electricity, gas and telephony markets. After new strategy was created in 2001, it emerged its UK telecommunications and Internet business and redefines it selves as solely energy business. The group currently operates through four businesses where US seated Pacific Corp operates as a regulated electricity business while the PPM acts as the competitive energy business. In the UK the regulated Infrastructure Division operates electricity transmission and distribution subsidiaries of the wholly owned UK holding company Scottish Power. Other subsidiaries comprise the group's competitive energy business, covering its generation assets; its commercial and energy management's activities and its energy supply business

units. The UK electricity and gas industries are regulated under the provisions of the Electricity Act, the Utility Act and the Energy Act 2004. These Laws includes price regulation for electricity transmission and distribution and gas transportation and of competition in electricity generation, gas storage and supply of both gas and electricity. Theses Acts requires licensing of industry participants and created regulatory bodies for each of the electricity and gas industries. The Authority is responsible for granting new licences or extension of the following activities: electricity generation, electricity transmission, electricity distribution, gas transportation and storage, gas shipping, supply of gas and electricity, modification of licences, term and revocation of licences, transmission price control and distribution price control. Striving to meet all environmental requirements and codes of practice Scottish Power publishes separately Environmental report where in detail provides information about regulation in following fields: air quality, endangered species, environmental clean ups, mining, water quality, emissions and contaminated sites.

Analysis of this company starts from their key drivers and examines its:

For the PacifiCorp this is achieving allowed regulatory rate of return on equity, managing the regulatory rate case process, managing a balanced power position, managing the impact of growing demand and improving operating and capital cost efficiency. PPM Energy drives availability of attractive business opportunities and favourable public policies. Optimising returns from its gas and power portfolio by actively seeking to lock in value inherent in the portfolio’s assets and contracts. Infrastructure division wants to maximise returns from investment in the regulatory asset base; secure a positive outcome and improve operating and capital cost efficiency. For the UK division drivers are by continuing to grow the customers base at optimal tariff levels, managing a balanced power position, expand renewable generation at appropriate rates of returns and improve operating and capital cost efficiency.

How they manage to present/or not in the report show the analyses below:

Step 1: Draw and explain where we are

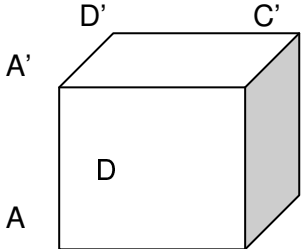

Where letters are chooses from the importance in companies report

- A= tangible assets= 9.602mil£
- B= creditors= 8.004mil.£
- C= provisions= 1.733mil£
- D=equity share holders fund= 3.982mil£

A'=increase in cash in year= 215 mil£ B'=turnover= 6.877m£
 C'= operating profit=152.6mil£ D'=dilluted loss per ordinary share=(16,83)%

This data shows very static company with 90% of tangible assets in their asset structure. Although with made balance scorecard SP was reluctant to go into greater detail in its outcomes what made me to believe that qualitative measures are of much less importance in its business structure are reported only if legislation requires to do so.

Inner body would have the following shape:

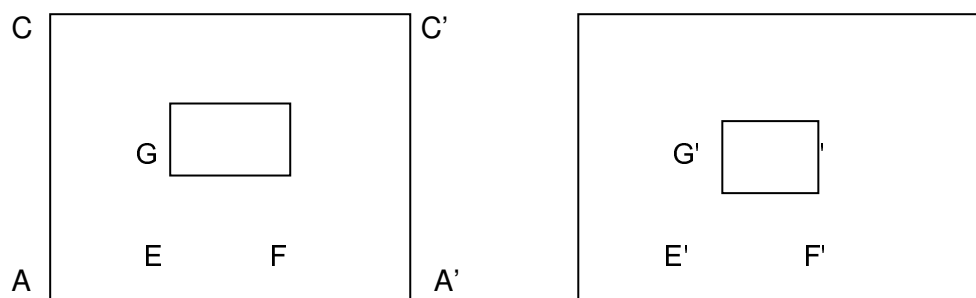

Where the cross relational relationship is established :or fixed asset are related to the less important category Human capital; Macro situation; Creativity and Press, while profit and Cash Flow are related to the more articulated categories such as ecology, risk management, project preparation and part of market share. This offsetting relationship is established while profit/loss accounts are more susceptible to environmental categories although provisions for accidents are made following auditor's recommendations. Very active risk management activities also could bring significant damage or profit increase in reports, as well as bad project preparation or bad decision or mergers. Report reviles us young company, dynamic, which is in search for itself decided that energy sector is one that it needs so sold internet and telecommunication services, than after few years in energy sector decides to drop PacifiCorp and sell it to MidAmerican for for 9.4 \$billion (where 4.54 billion of proceeds goes to shareholders. While Pacific Corp tangible assets worth 5856 mil £, has 6. mil employees what is 95% of working force in USA, or 41% of total working force lack of detailed explanation about selling and future investments plans are missing in the report.

Step 2: Establish real value of the qualitative assets

Real value would be inside reach if the following equation and data were studied:

$$Y = c + a_1 \cdot x_1 + a_2 \cdot x_2 + a_3 \cdot x_3 + a_4 \cdot x_4 + a_5 \cdot x_5 + \text{error term}$$

Where

X1= presents environmental influence and could be calculated as follows:

$$X1 = c_1 + b_1 \cdot z_1 + b_2 \cdot z_2 + b_3 \cdot z_3 + b_4 \cdot z_4 + b_5 \cdot z_5 + b_6 \cdot z_6 + \text{error}$$

Z1= amount of annual costs in all environmental media (air, water, ground, contamination etc)

Z2=investment in new technologies or protection of old ones (air, water, noise, biodiversity, etc)

Z3=legislative obligation (taxes, provisions, etc) and possible future obligations

Z5=provisions for environmental damage

Z6 = administrative and overheads related to environment

X2= presents risk factor influence and could be calculated as follows:

$$X2 = c_1 + b_1 \cdot z_1 + b_2 \cdot z_2 + b_3 \cdot z_3 + b_4 \cdot z_4 + b_5 \cdot z_5 + b_6 \cdot z_6 + \text{error}$$

Risk related to the group is those related to business. This implies that assets and business processes of the group may not perform as executed (uncertainties!), the sale of PacifiCorp may not progress or conclude as expected; changes in federal or state regulatory requirements in the US could negatively affect the group's turnover or profitability; changes in national regulatory requirements in the UK could negatively affect the group's turnover or profitability; pending legislation in the US could have currently unpredictable effects on the nature and extent of regulations to which the group is subject and on its revenues or profitability; the group cannot be certain of the extent or timing of the general trend towards tightening regulation of environmental impact and may therefore fail to meet predicted turnover or profitability; the group's business may be vulnerable to acts of terrorism; the group pension plan funding obligation are significant and are affected by factors beyond its direct control and the UK governments energy policy could change negatively affecting the context in which the group has established its UK strategy.

The second group of factors should consider following mostly financial factors

Such as: energy price risk, energy volumetric risk which is created by varying demand due to weather and economic circumstances and varying supply due to forced outages or other

physical supply and logistic information, credit risk, interest rate risk, inflation rate risk, insurance risk, foreign exchange translation and transaction risk, liquidity risk and derivative risk.

X3= presents project preparation influence and could be calculated as follows:

$$X3=c1+ b1*z1+b2*z2+b3*z3+b4*z4+b5*z5+b6*z6+error$$

Projects in energy sectors takes the totally opposite form than those marked by advertising companies. They employ's large amounts of financial means, huge infrastructure, a significant number of various experts, strong NPV as well as social, environmental and governmental cooperation, lasts a long time, and are subject to diversification and regulation.

Very little attention was devoted to this part, which could have very negative influence on SP business performance, lacking brand and clear future strategy. By selling one significant part in US connected with energy production, some short term miss management problems (negative result) switch the place with the long-term strategic important energy supply assets. USA market is always hungry for electricity (California Outages) and strong energy producer would have its place in tee future.

No words about future investment plans causes insecurity to investors, and by knowing SP history this company could enter into non-energy related future investments. Although human capital is mentioned and SP is equal opportunity employee there are no structure about employees, their age, sex, Company is on the other hand very proud with donations to political parties and gives exact amounts to each political group.

Step 3: Establish space considerations

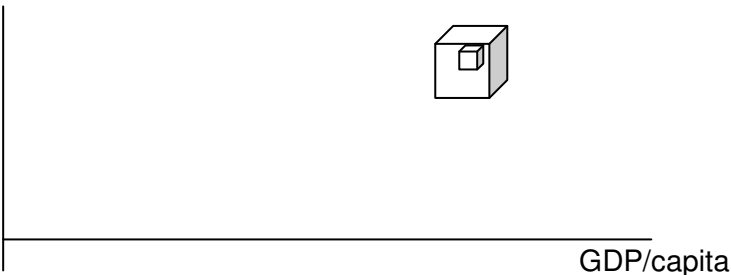

Very detailed accounting standards in two rich western countries are presented in report. But this detailing doesn't mean it has considered all the facts necessary. It is often the case that rich and especially energy related companies have sluggish management and ethical structure, and besides legal obligation it is not bordered to deal with anything else. Lack of strong

correlation between the ethical standard and GDP values and thoroughly presented as well as fears of some future uncertainties related to business made this company subordinated to sudden political and governmental changes.

Working on just two markets with the same lingual background's provides us with Information about current market share. Still it lacks the clear picture of assets and market share relationship and revenue terms, and there are no worries whatsoever about losing the total market share in USA by keeping only 265 employees and having only electricity providers and financial services.

Step 4: Establish time considerations

X4= presents market share influence and could be calculated as follows:

$$X4=c1+ b1*z1+b2*z2+b3*z3+b4*z4+b5*z5+b6*z6+error$$

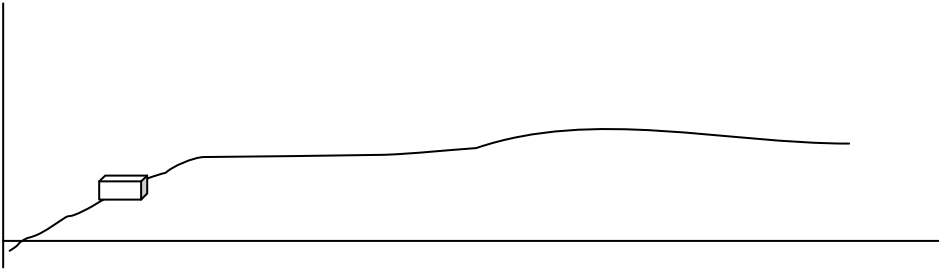

Diagram shows us young dynamic company in the static monopolistic highly regulated surroundings. Lack of real competition and partly monopoly role it doesn't seem to suit this company. Time of entrance and leaving the market, margin and de merger decisions seem to follow fluctuating trend and should be studied and presented in details. Consequences of huge investment decisions are vague and company seems to lead concretionary policy without giving the true values to come to a surplus what would certainly have happened if new accounting standards were followed.

3.3. UNILEVER

With the anniversary of 75 years of existence in 2005 interpolates Unilever among significant companies of our times. Although foods turnover declined in 2004 for 3% to 23.5 billion € what reduced operating profit BEIA (before exceptional items, goodwill amortisation and intangible assets) by 6,9% to €3,6 billion, Unilever is still number one in savoury and dressing business with brands Bertolli, Calce, Hellmann's and Knorr. Although overall growth in category of spreads and cooking products was holds back by lower sales of tail brands, which are being managed, for value and in which investment is low. Products such as healthy heart brands like Becel/ Flora, Blue Band, Country Crock and Rama. Beverage business sales decline by 3,9% with operating margin BEIA falling from 14,8% to 12,1% due to restructuring of Slim Fast production. Other marks in this fields provided different performance through world so Europe reduce Lipton tea consumption, while Asia increased demand for Brooke Bond and Sariwangi tea. Unilever's frozen food is number one in Europe mainly focused on Iglo/Birds Eye/Findus brands. Being the global foodservice industry that workers with caterers, restaurateurs, and major hotels and fast food chains around the world 2004 sales grew in low single digits was mainly driven by a strong performance in developing and emerging markets.

2004 was also unfavourable towards home and personal care goods whose turnover declined by 0,5% to €18,3 billion and reduced operating profit BEIA by 3,7% to € 2,8 billion. Six global brands Axe, Dove, Lux, Pond's, Rexona and Sun silk form the core of Unilever's business in their category making the company the leader in global deodorants and skin cleansing market, and among first three in mass market skin care and daily hair care. Unilever presents itself as the market leader in laundry products in developing and emerging markets with brands Comfort, Omo, Radiant, Skip, Snuggle and Surf available in over 100 countries.

Although underlying sales in Europe as a whole declined 2.8% due to continuing growth of hard discounters and the responses of traditional retailers looking to compete through value on both branded and private label products. Eastern Europe on contrary marked grew by over 5%, North America products grew by 1,5%, Latin America 7,2% and Africa and Middle East by modest 3,1%.

With 223 thousand people employed in more than 100 countries, Unilever achieves settled targets of sales growth reaching 3,6% from 2000-2004 getting 95% of sales in leading brands and increased in advertising and promotion as % of sales in 1,5%. Setted target of

€3,01 bn of restructuring and buying savings was exceeded, best foods synergy exceeded € 0,8 bn and capital productivity improved by 9 percentage points. Unilevers Annual Report discovers continuing drive toward employment of information technology, improving performance in managing the impact of our manufacturing activities, behaving responsible in order to have positive social impact, protesting and cherishing intellectual properties and government regulation. Although our products are subjects to seasonal fluctuation in sales, they are offset by network of customers on global level.

Unilever embraces differences and the fact that 30% of managers are women and senior management team is made up of 32 nationalities, with excellently presented and in detail calculated remuneration packages.

The analysis starts with establishing the details about corn stones of company's activities:

- A= fixed asset= €21.8111 million
- B=goodwill and intangible assets €15.338 mil
- C=credits due within one year € (14.570 mil)
- D= capital and reserves € 5.534 mil
- E=turnover=€40 366 mil
- F=result for the year retained € 33 mil
- G= net profit €1876 mil
- H=decrease in cash in the year €(672 mil)

The next step would be to study how and if qualitative description could help Unilever by recognizing the value important to company to find new, more profitable and socially responsible way to incorporates in its business structure.

After careful company study I have concluded that important factors that four major factors that drives the companies grows are Ecology questions, ecology, market share and macro economy. The results of the last few years shows that GDP factor such as GDP level doesn't proportionally influence product sale, on contrary richer countries reduced Unilevers mass product. The second fact that is important to Unilever management is ecology and environmental reasoning of single markets segments. Also, reversal approach is established between the market share, growth and ecology. In order to reverse the starting trend of lower turnover and lower sales in general strong marketing campaign with carefully structured universal massages would be of great help to contribute to further growth.



Putting an emphasis on the health and making innovative products for the fat population in western countries Unilever could benefit from excellent diversification in products and

regions. While more healthy products are more demanded in the western countries production of other product should be targeted more in developing world.

Huge goodwill and immaterial asset value point us to believe that this secondary cube is of more importance to the company and each activity should be separately monitored and valued numerically in order for company to continue its growth.

Basic classical linear regression should be expanded so from

$$Y=c+a_1*x_1+a_2*x_2+a_3*x_3+error$$

Y=group turnover (food, home and personal care and other operations)

X1=group operating profit (food, home and personal care, others operations)

X2=net operating assets (food, home and personal care, other operations)

X3=capital expenditure (food, home and personal care, other operation)

Should be widened for strong ecological background and strong marketing campaign.

Very clear articulated and widely promoted indiscriminately policy together with excellent rewarding system. While system is based on wide product are, covering globe human capital, communication and interaction could cause greater productive or sales mistakes if not properly valued. Quick change of goods, information followed by constant surveys, research and innovation are the heart of this company.

That why this second cube is 80% of the first that presents classical accounting values.

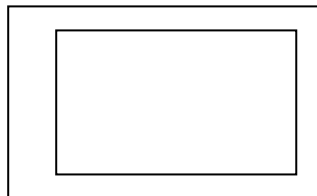

Next step that should be considered is spatial determination of Unilever operation.

Thorough picture of markets, regulation, development in infrastructures, number of stores, chains, marketing servicing, ratio between product category and sale should be considered. Informatics could be of primary importance but lack of infrastructure and possibilities sell could stop further growth,

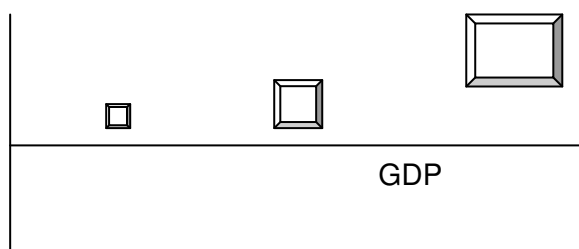

Table 6: Business results-Unilever

2004 mill €

| | Group turnover | Group operating profit | Net operating Assets | Capital expenditure |
|--------------------------------|-----------------------|-------------------------------|-----------------------------|----------------------------|
| Europe | 17 314 | 1 827 | 9 748 | 461 |
| North America | 8 908 | 259 | 6 031 | 161 |
| Africa, Middle East and Turkey | 3 263 | 302 | 1 111 | 116 |
| Asia and Pacific | 6 472 | 665 | 1 183 | 166 |
| Latin America | 4 212 | 358 | 2 838 | 101 |
| TOTAL: | 40 196 | 3 411 | 20 911 | 1 005 |

The third part is to establish the time line, strategic position and future prospects.

Age doesn't imply antiquities brain and attitude what this company proves but lack of future new goals, strategies except trying to make more of the poor Latin American and Eastern

Europeans market with products of greater qualities could be one of the dreams. Without dreams each oligopoly company doesn't have the chance to stay much on the market.

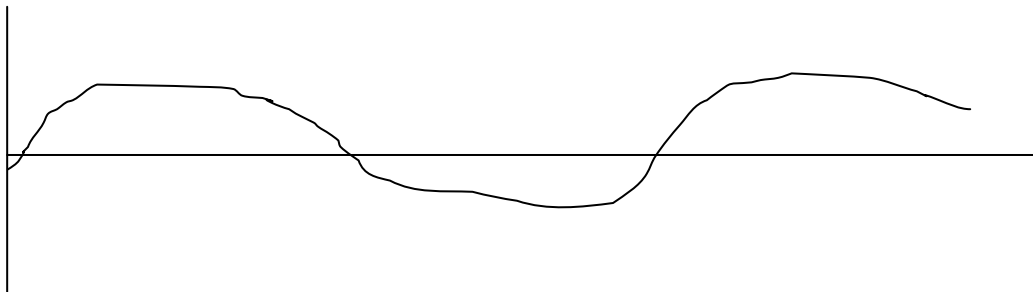

3.4. BRITISH TOBACCO

British American Tobacco p.l.c. Is a holding company, which owns directly or indirectly investments in the numerous companies' constitution the British American Tobacco Group. Their strategy of balanced approach to achieve growth, improving productivity. Managing business in a responsible manner and developing a winning organisation is strongly supported by 69 343 shareholders that owns 2 139 billion shares. Although holding 87 % of

total holders individuals contribute only 3,6% of issued ordinary share capital, while nominees companies with only 11% of total holders contribute with 66% of issued ordinary share capital. Strong winning policy is written in each page of annual report and profit orientation couldn't be expressed more than in BT organism. Only pluses on cigarette boxes attracted so much investors and flavour of success covers all the problems stated in some bodies else report: we have 2% greater operating profit excluding goodwill amortisation and exceptional items, we have 20% greater pre tax profit; we have 10% more adjusted diluted earnings per share; we have 8% more dividends per share and grew by 8% to 853 billion largely due to the impact of acquisition and the Reynolds American transaction. We love it!

Lets start with analysis by incorporating and other elements in our reasoning. I am going to research what stands behind the global brands Dunhill, Kent, Lucky Strike and Pall Mall that grew by 2% and Kent's that grew in last year by 10% to a new record high of 33 billion.

Firstly, I am going to introduce main elements of the basic accounting statements:

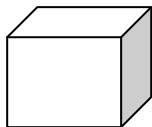

A=intangible assets=7.135 mil. B=Stocks=2.145 mil. C=Merger reserves=3.503 mil.
D=Net debt =5.119 A'=Revenue-subsidiary undertakings=31.811m B'=Profit=1.794 mil.
C'=Basic EPS =52.2 p D'= Increase in cash in the year 46 mil.

This corn stone value directs us toward company that with few famous brands and relatively simple products relies strongly on organic growth and acquisitions fighting fiercely legislative rules in order to reach more of the market share. Reports inform us about strong future growth in Venezuela, South Korea, Turkey, Hungary, Brazil, Australia and especially Russia.

Table shows the main elements of operation based on location of manufacture.

Turnover excluding duty excise and other taxes is hugest in Europe 46,89% and America Pacific 21,43% region with operating assets largely situated in Europe 43,91%. Somewhat similar operating profit picture could to one extend point us toward creative accountancy while charges include other operating charges that are different across regions and could be the source of future savings.

Interesting fact is that after all duties, excise and other taxes that reaches 38 % of revenue BT still presents profitable company with retained profit of 202 mil £.

Table 7 :Business results British Tobacco

| LAND | Turnover excluding duty, excise and taxes | % | Operating profit | % | Operating assets | % |
|------------------------|--|---------------|-----------------------------|---------------|-----------------------------|---------------|
| America Pacific | 2.307,00 | 21,43 | 649,00 | 25,71 | 391,00 | 10,15 |
| Asia Pacific | 1.290,00 | 11,98 | 411,00 | 16,28 | 555,00 | 14,40 |
| Latin America | 1.271,00 | 11,81 | 428,00 | 16,96 | 609,00 | 15,81 |
| Europe | 5.047,00 | 46,89 | 672,00 | 26,62 | 1.692,00 | 43,91 |
| Africa and Middle East | 849,00 | 7,89 | 364,00 | 14,42 | 606,00 | 15,73 |
| Total | 10.764,00 | 100,00 | 2.524,00 | 100,00 | 3.853,00 | 100,00 |

Strong goodwill value (excess of the cost of acquisition of a subsidiary or associate over the groups share of fair value of identifiable assets acquired) lead us to believe that project preparation and market share as well as proper promotion in order to avoid large scale scandals connected to brand gives rise to qualitative value of the company that is strongly hidden behind the huge words of success.

Environmental issue is concerned and touched only to extend in production. Although wisely put global legislative rules in air protection should be carefully monitored and right value put to environmental damage caused by each product. Only proper values written (could be very small letters) are rightful way to do. Is there a chance to make environmental ozone friendly, smelly, product and offset clear damage? Till that time this part is going to reduce companies values and must be incorporated in the price. Equation could follow the steps:

$$Y=C+ a1*x1+a2*x2+a3*x3+a4*x4+a5*x5+error$$

X1=air pollution caused by product

X2= current legal requirements

X3= future possible legally requirements that is connected to air quality

X4= costs to offset environmental damage

X5= investments in environment

Large part of company's activities is leaned to risk management activities. Net borrowings with amount of 5.112 mil £ deserves to be carefully monitored and all risks incorporated into analysis. Such a huge debt amount requires additional potential minus to future revenues. Financial assets and liabilities are recognised when the Group becomes a party to the contractual provisions of the relevant instrument and derecognised when it ceased to be a party to such provisions. In order to balance non-derivative financial assets with bob derivative liabilities their right ratio and accounting methods should be clearly stated in the balance sheet report in each moment. On derivative fin. assets are classified as either available for sale investments, loans and receivables or cash and cash equivalents. Apart

from available for sale investments they are stated at amortised cost using the effective interest method subject to reduction for allowances for estimated irrecoverable amounts. Available for sale investments are stated at fair value with changes in fair value being recognised directly in equity, When such investments are derecognised through disposal it is marked in income statement. Cash and cash equivalents include short-term highly liquid investments. On derivative fin. Liabilities are stated at amortised cost using the effective interest method.

$$Y1 = c + a1x1 + a2x2 + \text{error}$$

Where

Y1 = non-derivative fin. Instruments; x1 = interest rate; x2 = cash;

$$Y2 = c2 + b1z1 + b2z2 + b3z3 + \text{error}$$

Y2 = non-derivative fin. liability ; z1 = interest fixed; z2 = interest variable

The group issues derivatives/ financial instruments to hedge its exposure to foreign exchange and interest rate risks arising from operational, financing and investment activities. Derivatives fin assets and liabilities are stated at fair value, which includes accrued interest receivable and payable where relevant. For derivatives that are designated as cash flow hedges the changes in their fair values are recognised directly in equity to the extent that they are effective with the ineffective portion being recognised in the income statement. For derivatives that are designated as fair value hedges the carrying value of the hedged item is adjusted for the fair value changes attributable to the risk being hedged with the corresponding entry being made in the income statement. Derivatives that are designated as hedges of net investments in foreign operations the changes in their fair values are recognised directly in equity to the extent they are effective. For derivatives that do not qualify for hedge accounting or are not designated as hedges the changes in their fair values are recognised in the income statement in the period in which they arise.

$$Y3 = c + c1t1 + c2t2 + c3t3 + c4t4 + \text{error}$$

t1 = exchange rate (swaps, forward contracts)

t2 = change in interest rate (using agreements such as caps and collars)

t3 = change in equity

t4 = change in profit/loss

Proper human evaluation should be made not just for management personnel but also for the whole group. Such an analysis could give future potential rise/fall to the company.

This part could have a new entry such as how much and to what extent human health is endangered because of product usage and incorporate negative values in company's assets.

Although humanitarian help is stressed to be important unfortunately it includes payments to charitable purposes and political organisation thought Europe it doesn't provide us with the answer what kind and where exactly these donations took place and to what amount they present tax deductible amount. This valuation then could be as the plus sign added to marketing campaign and adds.

Project preparation has the value to incorporate all the direct and indirect effects and be connected with another very stressed part as the market share. An opportunity to win as larger as possible market share in the emerging countries BP tries and can win only if good project preparation is made. That includes research about new marketing ways and channels of distribution and sales, appealing marketing slogans, excellent logistics and excellently remunerated and incentives employees.

This part is strongly incorporated in the second stage of space research. It is noted that although significant assets are employed in Africa it hasn't sales reached wanted high-macroeconomic picture of countries with low GDP or mentality and religious reasons could be base to start research.

Next important part that is not incorporated in the asset intangible values is legislative differences and litigation cases. Litigation formula should be separated into medical reimbursement cases that are civil actions which seek to recover amounts spent by government entities and other third party providers on healthcare and welfare costs claimed to result from illnesses associated with smoking. B&W was named as a defendant in some 14 separate actions attempting to assert claims on behalf of classes of persons allegedly injured by smoking. The third group could be individual cases while approximately 3867 cases were pending against B&W filed by or on behalf of individuals in which it is contended that diseases or deaths have been caused by cigarette smoking or by exposure to environmental tobacco smoke. The fourth based group are conduct-based claims like US Department of Justice brought an action against various industry members, including B&W disengagements of profits pursuant to the federal Corrupt Organisation. Other claims such as cases pending on behalf of asbestos companies seeking reimbursement for costs and judgements paid in litigation brought by third parties against them.

Formula should incorporate number of cases and asked amounts, ratio of possible adverse verdict, amount of provision made for each claims according to verdict percentage. Closely connected to these subjects are uncertainties in legislation, outcome of the case, moral and ethics reasoning and system and value change.

Time consideration is important and in this case where “staying young” phrase is deeply rooted in the well being of the company. Although, hypothesis that inner qualitative values matters (huge goodwill) it seems that they are not established through qualitative approach, reasoning and calculation, but only through organic growth of merge ring and acquisitions.

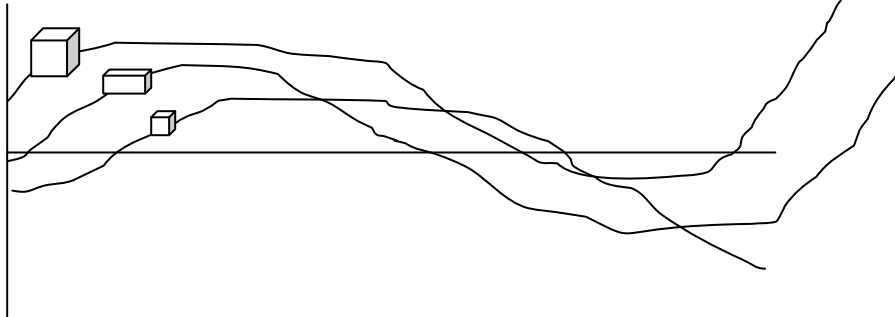

3.5. BANK-UBS

Reporting UBS standards allocates revenues and costs each report group separately that consists of: Wealth Management & Business Banking, Global Asset Management, Investment Bank, Wealth Management USA and Corporate Centre. The UBS maintain with praxes of good reporting and following accounting standard and regulators rules and started to imply IAS 32 and IAS 39 that requires to book credits, financial instruments and loans following fair value what has for its consequence to eliminate disadvantages in Profit Loss account that are caused by Treasury activities. This is the excellent example where the institution that lives from time, money, volatility and actual Information about financial instruments was forced to report changes due to the accounting standards.

2005 brought another change in the accounting where by following IASB Goodwill is going to be booked according to its market value and not according to time or worth value.

Main aims are much similar to the majority of companies and stretches from greater growth, 15% higher ROE, greater cost efficiency and optimising and greater value for owners. Its performance from year to year grows, with market established in western world Swiss, USA, UK and Canada.

UBS presents itself as the very reliable partner and in its reports elaborates too much detail about each accounting rules. This is excellent example where new way of accounting rules actual helps company to developed its quality and recognise all the obstacles it could found during path.

UBS doesn't inform us about any environmental or any other new credit instruments connected to it in order to attract more costumers. Although human value is the main driver it is hidden behind the numbers that has for its porpoise to satisfy some invisible stockholder. Very shy public appearance is not in its nature while it tries to reach middle and upper class individual, now an then good made slogan bake up with words of support for those disprivileged, in need for help or just tackling the important social subject such as environment, nationalism, racism, drug usage etc would not harm this giant.

Secrecy is normal in business world but it should not imply lack of creativity in new financial instruments, reporting, revealing a secret how to make an optimal portfolio or protect itself or customer from unconscious business partners

By making rules, those who like to stick to them would growth in them and provide more for surroundings.

4. CONCLUSION

The main value of this paper lies in the proposal that accounting procedures should be widened in order to incorporate all qualitative, space and time determinants that a company meets along its path in order to be more up to date, observe all obstacles and strengths that it has and circumstances that determine its growth. Although hard to measure, some qualitative descriptive elements should be stated and measured by inclusion of all variables relevant and calculate impact of certain variable on company's performance. By following today's praxis of reconciliation between the two different accounting standards (IFRS/GAAP) we are losing a lot of time and energy, while true determinants that impact the performance are laid aside. Today's accounting reports can't explain why the price of certain stock climbs while a company publishes unfavourable accounting reports or can't explain why in spite of a marvellous profit loss report, excellent media presentation the stock price is falling. By inclusion of additional elements a company's performance would be more transparent; the price speculation would not be speculation any more but based on certain facts and results of measurement and have the foot on the exact measures what is the feature of each science. Some empty calculations, price trading without firm and clear analysis made the economy easily judged and characterised as not so secure obligatory part of our daily life, or just like some unpleasant tax obligation.

Problems seen by paper is willingness to incorporate additional elements in a company, problems about quantifying the qualitative features, recognition of all important elements, lack of personal who is able to do that and those who are willing to control (auditors avoid environmental subjects) and our bounded rationality when specifying all the relevant facts. These problems are universally present in every part of the world, but there still stays the question: Whether the developing countries could afford thinking like these? Paper tried to answer these questions by examining the real life example and firmly states that benefits of having a broader system recognisable in the whole world not just exceeds the costs of measurement but additionally brings added value to a company, employees, society and the whole business community. Environmental problems and costs that their recognition and measurement brings shouldn't mean greater barriers to developing countries to develop but the additional tool how to better value and appreciate their natural resources. Some short-term goals can't be judged from the perspective we don't have to eat today but from the perspective let's make business today and tomorrow by harmonising our relationship with nature.

By widening balance sheet more transparent and valuable picture would be allocated to each company what would have for consequence better understanding of the stock price fluctuations and real value that company has. Sometimes human capital is not recognized and valued enough, some environmental damages would be avoided or bad advertisement recognized as the cause of price fall. If properly valuated and statistically followed secondary qualitative facts could be of enormous value to the company success. Paper presented how on very simple way even some well established, world companies could reach better results and more transparent way of doing business.

LITERATURE

- .. Accounting Theory, Wolk, Tearney
- .. Advanced Accounting, Haried, Imdieke, Smith
- .. British American Tobacco [www adrbny.com](http://www.adrbny.com)
- .. Corden, Economic Policy Exchange rate dynamics in OECD and EU acceding countries
- .. Edgar Feige, University of Wisconsin
- .. Chin M and Pasad 2000,00Medium term Determinants of Current Accounts in Industrial and Developing Countries NBER Working paper
- .. Economics, Organisation & Management, Milgrom Roberts
- .. Economics, Paul Samuelson
- .. Elements of Forecasting, Francis Diebold ,
- .. Essentials of Econometrics, Damodar Gujarati , Mc Graw Hill
- .. Estimating the size and growth of unrecorded economic activity in transition countries,
- .. Finanzbericht UBS [www ubs.com](http://www.ubs.com)
- .. Fundamental sof corporate finance, Brealey, Myers & Marcus
- .. Fundamentals of financial accounting, Welsch & Short
- .. Investment appraisal and financial decisions, Lumby, & Jones, Thomson ,London
- .. Investments, Kolb
- .. Macroeconomic Theory and Policy, William Branson,
- .. Microeconomics Gravelle & Rees
- .. OECD
- .. Principles of Corporate Finance, Brealy & Myers
- .. [ww eu.org](http://ww.eu.org)
- .. [www ina.hr](http://www.ina.hr)
- .. [WWW janaf.hr](http://WWW.janaf.hr)
- .. [www pliva.hr](http://www.pliva.hr)
- .. [www unilever .com](http://www.unilever.com)
- .. [www wpp.com](http://www.wpp.com)
- .. [www cia.com](http://www.cia.com)
- .. [www hgk .hr](http://www.hgk.hr)
- .. [www lura .hr](http://www.lura.hr)
- .. [www scottishpower.com](http://www.scottishpower.com)
- .. [www un.org](http://www.un.org)
- .. [www zse.hr](http://www.zse.hr)

LIST OF TABLES:

TABLE 1: CREATIVE ACCOUNTANCY

TABLE 2 :EARNING MANAGEMENT TECHNIQUES

TABLE 3: SCORECARD MEASURES

TABLE 4: DIFFERENCE BETWEEN IFRS AND US GAAP

TABLE 5: RISK CATEGORIES