



Munich Personal RePEc Archive

## **Bilateral Approach to the Secretary Problem**

Ramsey, David M. and Szajowski, Krzysztof

Department of Mathematics and Statistics, University of Limerick ,  
Plassey, Limerick, Ireland, Institute of Mathematics and Computer  
Science, Wrocław University of Technology, Wybrzeże  
Wyspińskiego 27, 50-370 Wrocław, Poland

2000

Online at <https://mpra.ub.uni-muenchen.de/19996/>

MPRA Paper No. 19996, posted 16 Jan 2010 20:42 UTC

# Chapter 1

## Bilateral Approach to the Secretary Problem

David Ramsey and Krzysztof Szajowski

*ABSTRACT* A mathematical model of competitive selection of the applicants for a post is considered. There are  $N$  applicants of similar qualifications on an interview list. The applicants come in a random order and their salary demands are distinct. Two managers, I and II, will interview them one at a time. The aim of the manager is to obtain the applicant which demands minimal salary. The candidate can be accepted only at the moment of its appearance. When both manager want to accept the same candidate, then some rule of assignment to one of the manager is applied. Any candidate hired by the manager will accept the offer with some given probability. An candidate can be hired only at the moment of its appearance. At each moment  $n$  one candidate is presented. The considered problem is a generalisation of the best choice problem with uncertain employment and the game version of it with priority or random priority. The general stopping game model is constructed. The algorithms of construction of the game value and the equilibrium strategies are given. An example is solved.

### 1.1 Introduction

This paper deals with mathematical model of competitive selection of the applicants for a post. There are  $N$  applicant of similar qualification on an interview list. The applicants come in a random order and their salary demands are distinct. Two managers, called Player 1 and Player 2, will interview them one at a time. The aim of the manager is to obtain the applicant which demands minimal salary. The candidate can be accepted only at the moment of its appearance. When both manager want to accept the same candidate, then some rule of assignment to one of the manager is applied. Any candidate hired by the manager will accept the offer of job with some given probability. An candidate can be hired only at the moment of its appearance. At each moment  $n$  one candidate is presented. The considered problem is related both to the uncertain employment considered by [12] and to the competitive optimal stopping problem with priority (see [4]) or more generally with random priority of the players (see [7], [14]).

Let us formulate the optimal stopping problem with uncertain employment considered by Smith [12] (see also [15]) in rigorous way. Let a homogeneous

---

<sup>0</sup>AMS Subject Classifications. 60G40, 62L15, 90D15.

Key words. optimal stopping problem, game variant, Markov process, random priority, secretary problem

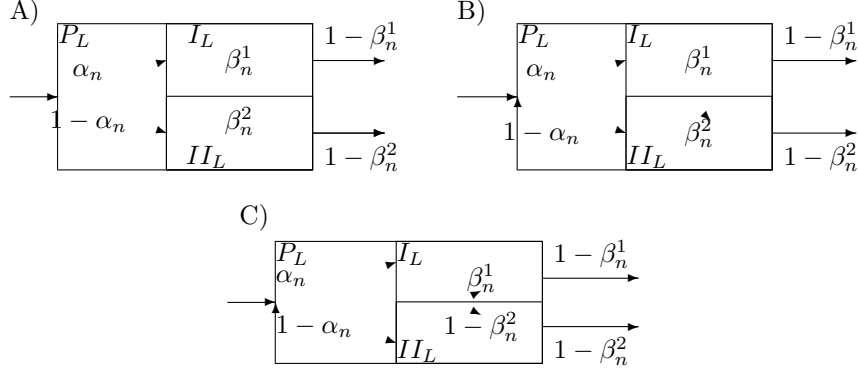

FIGURE 1.1. The schemes of decision processes

Markov process  $(X_n, \mathcal{F}_n, \mathbf{P}_x)_{n=0}^N$  be defined on probability space  $(\Omega, \mathcal{F}, \mathbf{P})$  with fixed state space  $(\mathbb{E}, \mathcal{B})$ . Define the gain function  $f : \mathbb{E} \rightarrow \mathfrak{R}$ . Let  $\mathfrak{M}^N$  be a set of sequences  $\bar{\mu} = \{\mu_n\}_{n=0}^N$  of  $\{0, 1\}$ -valued random variables such that  $\mu_n$  is  $\mathcal{F}_n$ -measurable for every  $n$ . Let  $\{\eta_n\}_{n=0}^N$  be a sequence of i.i.d. r.v. with the uniform distribution on  $[0, 1]$ , independent of  $\{X_n\}_{n=0}^N$  and  $\bar{\mu}$  and let  $\alpha = \{\alpha_n\}_{n=0}^N$  be the sequence of real numbers,  $\alpha_n \in [0, 1]$ . Define  $\tau_\alpha(\bar{\mu}) = \inf\{n \geq 0 : \mu_n = 1, \eta_n \leq \alpha_n\}$ . In the optimal stopping problem with uncertain employment the aim is to find  $\bar{\mu}^*$  such that

$$E_x f(X_{\tau_\alpha(\bar{\mu}^*)}) = \sup_{\bar{\mu} \in \mathfrak{M}^N} E_x f(X_{\tau_\alpha(\bar{\mu})}) \text{ for all } x \in \mathbb{E}$$

and to determine the function  $v(x) = E_x f(X_{\tau_\alpha(\bar{\mu}^*)})$ . We can look at the above problem as a problem of one decision-maker who wants to accept, on the basis of sequential observation, the most profitable state of the Markov process which appeared in the realization but the solicited state is available with some probability only. The availability is unknown before solicitation. If the decision-maker has made unsuccessful stop he is able to choose any next state under the same rules. The availability is described by the sequence  $\alpha$ .

In bilateral approach each player can get at most one of the state from the realization of the Markov chain. Since there is only one random sequence  $\{X_n\}_{n=0}^N$  in a trial, at each instant  $n$  only one player can obtain a realization  $x_n$  of  $X_n$ . Both players together can accept at most two objects. The problem of assigning the objects to the players when both want to accept the same one can be solved in many ways. In [2] Dynkin assumed that for odd  $n$  Player 1 can choose  $x_n$  and for even  $n$  Player 2 can choose. Other authors solve the problem by more or less arbitrary definition of the payoff function. Sakaguchi [11] considered some version of the bilateral sequential games related to the no-information secretary problem with uncertain employment. There were investigated the two-person non-zero-sum games with one or two sets of  $N$  objects in the condition of the secretary problem. In the case of one set of objects it can happens that both players attempt to accept the same object. In this case players have half success

which is taken into account in the payoff function. Another approach assumes the priority for one decision-maker (see papers by Sakaguchi [10], Enns & Ferenstein [3], Radzik & Szajowski [6], Ravindran & Szajowski [9]) or the random priority (the paper by Fushimi[5], Radzik & Szajowski [7] and Szajowski [14]).

The model of competitive choice of the required object with the uncertain employment and the random priority has been formulated and preliminary results have been obtained by Szajowski [13]. At each moment  $n$  the state of the Markov process  $x_n$  is presented to both players. If the players have not already made an acceptance there are following possibilities. If only one of them would like to accept the state then he tries to take it. In this moment the random mechanism assign availability to the state (which can depend on the player and the moment of decision  $n$ ).

**Model A.** This is the approach which has been considered by the authors in [8].

- (i) If both of them are interested in this state then at first the random device chooses the player who will first solicit the state. The availability of the state is similar as in the situation when only one player want to take it.
- (ii) If state is not available for player chosen by random device then the observed state at moment  $n$  is lost as in the case when both players reject it. The next state in the sequence is interviewed.

**Model B.** The model differs from **Model A** only in the case when both players would like to accept the same state. So that point (i) is there same.

If random device chooses Player 1 and the state is not available for him (lottery decides about that) then the observed state at moment  $n$  is solicited by Player 2. The state is available for him as in the situation when only Player 2 tries to take it (the random experiment decides about it). If the state is not available then it is lost and the next state in the sequence is interviewed.

**Model C.** The model differs from **Model A** and **B** in the case when both players would like to accept the same state. This model admits that if the state is not available for the player chosen by device then the another player is able to solicited the state.

Fig. 1.1 presents the scheme of the decision process in each model. The lottery  $P_L$  assigns the priority to the players. The random devices  $I_L$  and  $II_L$  describe availability of the state to Player 1 and Player 2, respectively. In **Model B** there is a door between  $I_L$  and  $II_L$  which can be opened from the room  $I_L$ . In **Model C** the door handles are from both sides.

This paper deals with the extended model described in the point **Model C**. In Section 1.2 the formal description of two step random assignment is given. The algorithms solution of the game related to the model described in Section 1.2 is presented in Section 1.3. The examples are solved in Section 1.4.

## 1.2 Two Step Random Assignment

Let  $(X_n, \mathcal{F}_n, \mathbf{P}_x)_{n=0}^N$  be a homogeneous Markov chain defined on a probability space  $(\Omega, \mathcal{F}, \mathbf{P})$  with state space  $\mathbb{E} \times \mathbb{E}$  and let  $f_1 : \mathbb{E} \times \mathbb{E} \rightarrow \mathfrak{R}$  and  $f_2 : \mathbb{E} \times \mathbb{E} \rightarrow \mathfrak{R}$  be  $\mathcal{B} \times \mathcal{B}$  real valued measurable functions. The horizon  $N$  is finite. Player  $i$  ( $i \in \{1, 2\}$ ) observes the Markov chain and tries to maximise his payoff defined by the function  $f_i$ . Each realisation  $x_n$  of  $X_n$  can be accepted by at most one player and neither player can accept more than one realisation of the chain. It is assumed there is a lottery, which decides which player has priority when both players wish to accept the same realisation. Also, it is assumed that if a player wishes to accept a realisation  $x_n$  of  $X_n$  and has priority, then that player obtains that realisation with some probability strictly non-zero and strictly less than one (ie uncertain employment). If a player has not accepted any of the previous realisations at stage  $n$ , then he has two options. The first is to solicit the observed state of the process, the second is to reject it. Once a player has accepted one of the realisations, then he no longer takes part in the game.

If both players wish to accept the same realisation, then the lottery chooses which player has priority. Let  $(\{\epsilon_n\}_{n=0}^N, \{\alpha_n\}_{n=0}^N)$  be the description of lottery, where the  $\epsilon_i$ ,  $i = 0, 1, \dots, N$  are a sequence of i.i.d r.v.s from the  $[0, 1]$  uniform distribution and the  $\alpha_i$ ,  $i = 0, 1, \dots, N$  are real numbers,  $\alpha_i \in [0, 1]$ . When both players wish to accept the same realisation  $x_n$  of  $X_n$ , then Player 1 has priority if  $\epsilon_n \leq \alpha_n$ , otherwise Player 2 has priority. Similarly, the lottery  $(\{\eta_n^i\}_{n=0}^N, \{\beta_n^i\}_{n=0}^N)$  describes the availability of the  $n$ th realisation of the chain to the  $i$ th player. When only Player 1 (Player 2) accepts state  $x$  ( $y$ ) then Player 1 obtains  $g_1(x) = \sup_{y \in \mathbb{E}} f_1(x, y)$  ( $g_2(y) = \inf_{x \in \mathbb{E}} f_1(x, y)$ ) by assumption. Similarly, when only Player 1 (Player 2) accepts state  $x$  ( $y$ ) then Player 2 obtains  $g_3(x) = \inf_{y \in \mathbb{E}} f_2(x, y)$  ( $g_4(y) = \sup_{x \in \mathbb{E}} f_2(x, y)$ ). If neither player accepts a realisation, then they both gain 0.

Let  $\Omega^N$  be the aggregation of sequences  $\bar{\sigma} = \{\omega_n\}_{n=0}^N$  of  $\{0, 1\}$ -valued random variables such that  $\omega_n$  is  $F_n$ -measurable,  $n = 0, 1, \dots, N$ . If a player uses  $\bar{\sigma}$ , then  $\sigma_n = 1$  means that he declares willingness to accept the realisation  $x_n$  of  $X_n$ . If  $\sigma_n = 0$ , then the player is not interested in accepting the realisation  $x_n$ . Denote  $\Omega_k^N = \{\bar{\sigma} : \sigma_0 = 0, \sigma_1 = 0, \dots, \sigma_{k-1} = 0\}$ . Let  $\Lambda_k^N$  and  $\Gamma_k^N$  be copies of  $\Omega_k^N$  ( $\Omega_k^N = \Omega_0^N$ ). One can define the sets of strategies  $\bar{\Lambda}^N = \{(\bar{\lambda}, \{\bar{\sigma}_n^1\}) : \lambda \in \Lambda^N, \bar{\sigma}_n^1 \in \Lambda_{n+1}^N \forall n\}$  and  $\bar{\Gamma}^N = \{(\bar{\gamma}, \{\bar{\sigma}_n^2\}) : \bar{\gamma} \in \Gamma^N, \bar{\sigma}_n^2 \in \Gamma_{n+1}^N \forall n\}$  for Players 1 and 2 respectively. The strategies  $\bar{\lambda}$  and  $\bar{\gamma}$  are applied by Player 1 and Player 2 respectively, until the first of the two players has obtained one of the realisations of the Markov chain. After that point the other player, Player  $i$  say, continues alone using strategy  $\bar{\sigma}_n^i$ ,  $i = 1, 2$ .

Let  $E_x f_1^+(X_n) < \infty$ ,  $E_x f_1^-(X_n) < \infty$ ,  $E_x f_2^+(X_m) < \infty$  and  $E_x f_2^-(X_m) < \infty$  for  $n, m = 0, 1, \dots, N$  and  $x \in \mathbb{E}$ . Let  $\psi \in \bar{\Lambda}^N$  and  $\tau \in \bar{\Gamma}^N$ . Based on the strategies  $\psi$  and  $\tau$  used by Player 1 and Player 2 respectively, the definition of the lotteries and the type of model used, the expected gains  $\bar{R}_{1, \bullet}(x, \psi, \tau)$  and  $\bar{R}_{2, \bullet}(x, \psi, \tau)$  for Player 1 and Player 2 respectively can be obtained. In this way the form of the game  $(\bar{\Lambda}^N, \bar{\Gamma}^N, \bar{R}_{1, \bullet}(x, \psi, \tau), \bar{R}_{2, \bullet}(x, \psi, \tau))$  is defined. This game is denoted by  $G^\bullet$ . For zero sum games the normal form of the game can be

simply defined by  $(\bar{\Lambda}^N, \bar{\Gamma}^N, \bar{R}_{1,\bullet}(x, \psi, \tau))$  since  $\bar{R}_{1,\bullet}(x, \psi, \tau) = -\bar{R}_{2,\bullet}(x, \psi, \tau)$ . The three models considered in the introduction are presented in the following section for both zero sum and non-zero sum games.

**Definition 1.2.1** *The pair  $(\psi^*, \tau^*)$  is an equilibrium point in the game  $G^\bullet$  if for every  $x \in \mathbb{E}$ ,  $\psi \in \bar{\Lambda}^N$  and  $\tau \in \bar{\Gamma}^N$  the following two inequalities hold*

$$\bar{R}_{1,\bullet}(x, \psi, \tau^*) \leq \bar{R}_{1,\bullet}(x, \psi^*, \tau^*) \quad (1.1)$$

$$\bar{R}_{2,\bullet}(x, \psi^*, \tau) \leq \bar{R}_{2,\bullet}(x, \psi^*, \tau^*) \quad (1.2)$$

*In the particular case of zero-sum games, these conditions simplify to*

$$\bar{R}_{1,\bullet}(x, \psi, \tau^*) \leq \bar{R}_{1,\bullet}(x, \psi^*, \tau^*) \leq \bar{R}_{1,\bullet}(x, \psi^*, \tau) \quad (1.3)$$

The aim is to construct equilibrium pairs  $(\psi^*, \tau^*)$ . After one of the players accepts realisation  $x_n$  at time  $n$ , the other player will try to maximise his gain without any disturbance from the player choosing first, as in the optimal stopping problem with uncertain employment (see Smith [12]). Thus, if neither player has accepted a realisation up to stage  $n$ , the players must take into account the potential danger from a future decision of the opponent, in order to decide whether or not to accept the realisation  $x_n$  of  $X_n$ . In order to do this, they consider some auxiliary game  $G_a^\bullet$ .

Let  $\psi = (\bar{\lambda}, \{\bar{\sigma}_n^1\})$  and  $\tau = (\bar{\gamma}, \{\bar{\sigma}_n^2\})$ . Define  $s_0(x, y) = \beta_N^2 f_2(x, y) + (1 - \beta_N^2) g_3(x)$ ,  $S_0(x, y) = \beta_N^1 f_1(x, y) + (1 - \beta_N^1) g_2(y)$  and

$$s_n(x, y) = \sup_{t \in \Gamma_{N-n}^N} E_y f_2(x, X_{\sigma(\tau, \beta^2)}) \quad (1.4)$$

$$S_n(x, y) = \sup_{s \in \Lambda_{N-n}^N} E_x f_1(X_{\sigma(\psi, \beta^1)}, y) \quad (1.5)$$

for all  $x, y \in \mathbb{E}$ ,  $n = 1, 2, \dots, N$ , where  $\sigma(\psi, \beta^1) = \inf\{0 \leq n \leq N : \sigma_n^1 = 1, \eta_n^1 \leq \beta_n^1\}$  and  $\sigma(\tau, \beta^2) = \inf\{0 \leq n \leq N : \sigma_n^2 = 1, \eta_n^2 \leq \beta_n^2\}$ . By backward induction (see Bellman [1]), the functions  $s_n(x, y)$  can be constructed as  $s_n(x, y) = \max\{\beta_n^2 f_2(x, y) + (1 - \beta_n^2) T_2 s_{n-1}(x, y), T_2 s_{n-1}(x, y)\}$  and the functions  $S_n(x, y)$  has the form  $S_n(x, y) = \max\{\beta_n^1 f_1(x, y) + (1 - \beta_n^1) T_1 S_{n-1}(x, y), T_1 S_{n-1}(x, y)\}$  respectively, where  $T_1 f(x, y) = E_y f(x, X_1)$  and  $T_2 f(x, y) = E_x f(X_1, x)$ . The operations minimum, maximum,  $T_2$  and  $T_1$  all preserve measurability. Hence  $s_n(x, y)$  and  $S_n(x, y)$  are  $B \otimes B$  measurable. If Player 1 has obtained  $x$  at moment  $n$  and Player 2 has not yet obtained any realisation, then the expected gain of Player 2 is given by  $h_2(n, x)$  ( $i \in \{1, 2\}$ ), where

$$h_2(n, x) = E_x s_{N-n-1}(x, X_1) \quad (1.6)$$

for  $n = 0, 1, \dots, N - 1$  and  $h_2(N, x) = g_3(x)$ . Let the future expected reward of Player 1 in such a case be denoted  $h_1(n, x)$ . If the game is a zero sum game, then  $h_1(n, x) = -h_2(n, x)$ .

When Player 2 is the first player to obtain a realisation at time  $n$ , then the expected gain of Player 1 is given by  $H_1(n, x)$ , where

$$H_1(n, x) = E_x S_{N-n-1}(X_1, x) \quad (1.7)$$

for  $n = 0, 1, \dots, N - 1$  and  $H_1(N, x) = g_2(x)$ . Let the future expected reward of Player 2 in such a case be denoted  $H_2(n, x)$ . If the game is a zero sum game, then  $H_2(n, x) = -H_1(n, x)$ .

Based upon the solutions of the optimisation problems when a player remains alone in the decision process, we can consider such an auxiliary game  $G_a^\bullet$ . The form of this game depends on the model determining what happens when both players wish to accept the same state.

### 1.3 The extended model

Assume that the model deciding the priority assignment is Model  $C$ , as given in the introduction. The game related to Model  $C$  will be denoted  $G^C$ . The sets of strategies available to Player 1 and Player 2 are  $\bar{\Lambda}^N$  and  $\bar{\Gamma}^N$  respectively. For  $\psi = (\bar{\lambda}, \{\bar{\sigma}_n^1\}) \in \bar{\Lambda}^N$  and  $\tau = (\bar{\gamma}, \{\bar{\sigma}_n^2\}) \in \bar{\Gamma}^N$ , we define the following random variables

$$\begin{aligned} \lambda_{\alpha, \beta^1, \beta^2}(\psi, \tau) &= \inf\{0 \leq n \leq N : (\lambda_n = 1, \gamma_n = 1, \epsilon_n \leq \alpha_n, \eta_n^1 \leq \beta_n^1) \\ &\quad \text{or } (\lambda_n = 1, \gamma_n = 0, \eta_n^1 \leq \beta_n^1) \\ &\quad \text{or } (\lambda_n = 1, \gamma_n = 1, \epsilon_n > \alpha_n, \eta_n^2 > \beta_n^2, \eta_n^1 \leq \beta_n^1)\} \\ \gamma_{\alpha, \beta^1, \beta^2}(\psi, \tau) &= \inf\{0 \leq n \leq N : (\lambda_n = 1, \gamma_n = 1, \epsilon_n > \alpha_n, \eta_n^2 \leq \beta_n^2) \\ &\quad \text{or } (\lambda_n = 0, \gamma_n = 1, \eta_n^2 \leq \beta_n^2) \\ &\quad \text{or } (\lambda_n = 1, \gamma_n = 1, \epsilon_n \leq \alpha_n, \eta_n^1 > \beta_n^1, \eta_n^2 \leq \beta_n^2)\} \end{aligned}$$

Let

$$\begin{aligned} \rho_1(\psi, \tau) &= \lambda_{\alpha, \beta^1, \beta^2}(\psi, \tau) \mathbb{I}_{\{\lambda_{\alpha, \beta^1, \beta^2}(\psi, \tau) < \gamma_{\alpha, \beta^1, \beta^2}(\psi, \tau)\}} \\ &\quad + \sigma_{\gamma_{\alpha, \beta^1, \beta^2}}(\psi, \beta^1) \mathbb{I}_{\{\lambda_{\alpha, \beta^1, \beta^2}(\psi, \tau) > \gamma_{\alpha, \beta^1, \beta^2}(\psi, \tau)\}} \end{aligned}$$

and

$$\begin{aligned} \rho_2(\psi, \tau) &= \gamma_{\alpha, \beta^1, \beta^2}(\psi, \tau) \mathbb{I}_{\{\lambda_{\alpha, \beta^1, \beta^2}(\psi, \tau) > \gamma_{\alpha, \beta^1, \beta^2}(\psi, \tau)\}} \\ &\quad + \sigma_{\lambda_{\alpha, \beta^1, \beta^2}}(\tau, \beta^2) \mathbb{I}_{\{\lambda_{\alpha, \beta^1, \beta^2}(\psi, \tau) < \gamma_{\alpha, \beta^1, \beta^2}(\psi, \tau)\}} \end{aligned}$$

We have

$$\begin{aligned} \bar{R}_{1,C}(x, \psi, \tau) &= E_x f_1(X_{\rho_1}(\psi, \tau), X_{\rho_2}(\psi, \tau)) \\ \bar{R}_{2,C}(x, \psi, \tau) &= E_x f_2(X_{\rho_1}(\psi, \tau), X_{\rho_2}(\psi, \tau)) \end{aligned}$$

In the auxiliary game  $G_a^C$ , the sets of strategies available to Player 1 and Player 2 are  $\Lambda^N$  and  $\Gamma^N$  respectively. For  $\bar{\lambda} \in \Lambda^N$  and  $\bar{\gamma} \in \Gamma^N$  we define the

random variables

$$\begin{aligned}
 \bar{\lambda}_{\alpha, \beta^1, \beta^2}(\bar{\lambda}, \bar{\gamma}) &= \inf\{0 \leq n \leq N : (\lambda_n = 1, \gamma_n = 1, \epsilon_n \leq \alpha_n, \eta_n^1 \leq \beta_n^1) \\
 &\quad \text{or } (\lambda_n = 1, \gamma_n = 0, \eta_n^1 \leq \beta_n^1) \\
 &\quad \text{or } (\lambda_n = 1, \gamma_n = 1, \epsilon_n > \alpha_n, \eta_n^2 > \beta_n^2, \eta_n^1 \leq \beta_n^1)\} \\
 \bar{\gamma}_{\alpha, \beta^1, \beta^2}(\bar{\lambda}, \bar{\gamma}) &= \inf\{0 \leq n \leq N : (\lambda_n = 1, \gamma_n = 1, \epsilon_n > \alpha_n, \eta_n^2 \leq \beta_n^2) \\
 &\quad \text{or } (\lambda_n = 0, \gamma_n = 1, \eta_n^2 \leq \beta_n^2) \\
 &\quad \text{or } (\lambda_n = 1, \gamma_n = 1, \epsilon_n \leq \alpha_n, \eta_n^1 > \beta_n^1, \eta_n^2 \leq \beta_n^2)\}
 \end{aligned}$$

As long as  $\bar{\lambda}_{\alpha, \beta^1, \beta^2}(\bar{\lambda}, \bar{\gamma}) \leq N$  or  $\bar{\gamma}_{\alpha, \beta^1, \beta^2}(\bar{\lambda}, \bar{\gamma}) \leq N$ , the payoff function for the  $i$ -th player is defined as follows

$$\begin{aligned}
 r_i(\bar{\lambda}_{\alpha, \beta^1, \beta^2}(\bar{\lambda}, \bar{\gamma}), \bar{\gamma}_{\alpha, \beta^1, \beta^2}(\bar{\lambda}, \bar{\gamma})) &= h_i(\bar{\lambda}_{\alpha, \beta^1, \beta^2}(\bar{\lambda}, \bar{\gamma}), X_{\bar{\lambda}_{\alpha, \beta^1, \beta^2}(\bar{\lambda}, \bar{\gamma})}) \\
 &\quad \times \mathbb{I}_{\{\bar{\lambda}_{\alpha, \beta^1, \beta^2}(\bar{\lambda}, \bar{\gamma}) < \bar{\gamma}_{\alpha, \beta^1, \beta^2}(\bar{\lambda}, \bar{\gamma})\}} \\
 &\quad + H_i(\bar{\gamma}_{\alpha, \beta^1, \beta^2}(\bar{\lambda}, \bar{\gamma}), X_{\bar{\gamma}_{\alpha, \beta^1, \beta^2}(\bar{\lambda}, \bar{\gamma})}) \\
 &\quad \times \mathbb{I}_{\{\bar{\lambda}_{\alpha, \beta^1, \beta^2}(\bar{\lambda}, \bar{\gamma}) \geq \bar{\gamma}_{\alpha, \beta^1, \beta^2}(\bar{\lambda}, \bar{\gamma})\}}
 \end{aligned} \tag{1.8}$$

otherwise the payoff to each player is 0.

Firstly, we consider zero sum games. As a solution to such a game, we look for an equilibrium pair  $(\bar{\lambda}^*, \bar{\gamma}^*)$  such that

$$\begin{aligned}
 R(x, \bar{\lambda}_{\alpha, \beta^1, \beta^2}(\bar{\lambda}, \bar{\gamma}^*), \bar{\gamma}_{\alpha, \beta^1, \beta^2}(\bar{\lambda}, \bar{\gamma}^*)) &\leq R(x, \bar{\lambda}_{\alpha, \beta^1, \beta^2}(\bar{\lambda}^*, \bar{\gamma}^*), \bar{\gamma}_{\alpha, \beta^1, \beta^2}(\bar{\lambda}^*, \bar{\gamma}^*)) \\
 &\leq R(x, \bar{\lambda}_{\alpha, \beta^1, \beta^2}(\bar{\lambda}^*, \bar{\gamma}), \bar{\gamma}_{\alpha, \beta^1, \beta^2}(\bar{\lambda}^*, \bar{\gamma}))
 \end{aligned} \tag{1.9}$$

for all  $x \in \mathbb{E}$ , where

$$R(x, \bar{\lambda}_{\alpha, \beta^1, \beta^2}(\bar{\lambda}, \bar{\gamma}), \bar{\gamma}_{\alpha, \beta^1, \beta^2}(\bar{\lambda}, \bar{\gamma})) = E_x r_1(\bar{\lambda}_{\alpha, \beta^1, \beta^2}(\bar{\lambda}, \bar{\gamma}), \bar{\gamma}_{\alpha, \beta^1, \beta^2}(\bar{\lambda}, \bar{\gamma})).$$

As in Model A, we can define a sequence  $v_n(x)$ ,  $n = 0, 1, \dots, N + 1$  on  $\mathbb{E}$  by setting  $v_{N+1}(x) = 0$  and

$$v_n(x) = \text{val} \begin{bmatrix} \alpha_n(\beta_n^1 h_1(n, x) + (1 - \beta_n^1)g(n, x, \beta_n^2)) & G(n, x, \beta_n^1) \\ +(1 - \alpha_n)(\beta_n^2 H_1(n, x) + (1 - \beta_n^2)G(n, x, \beta_n^1)) & T v_{n+1}(x) \\ g(n, x, \beta_n^2) & \end{bmatrix} \tag{1.10}$$

for  $n = 0, 1, \dots, N$ , where  $G(n, x, \beta_n^1) = \beta_n^1 h_1(n, x) + (1 - \beta_n^1)T v_{n+1}(x)$  and  $g(n, x, \beta_n^2) = \beta_n^2 H_1(n, x) + (1 - \beta_n^2)T v_{n+1}(x)$ . By subtracting  $T v_{n+1}(x)$  from each entry above, it can be seen that the game above is equivalent to a game with matrix A, where

$$A = \begin{bmatrix} \mathbf{a}_{ss} & \mathbf{a}_{sc} \\ \mathbf{a}_{cs} & \mathbf{a}_{cc} \end{bmatrix} = \begin{bmatrix} \alpha(a + (1 - \beta)b) & a \\ +(1 - \alpha)(b + (1 - \gamma)a) & 0 \\ b & \end{bmatrix} \tag{1.11}$$

where  $a, b, \alpha, \beta, \gamma$  are real numbers and  $\alpha, \beta, \gamma \in [0, 1]$ . By direct checking we obtain



**Lemma 1.3.1** *The two person zero-sum game with payoff matrix  $A$  given above has an equilibrium point  $(\epsilon, \delta)$  in pure strategies, where*

$$(\epsilon, \delta) = \begin{cases} (s, s) & \text{if } (1 - (1 - \alpha)\gamma)a \geq \alpha\beta b \cap (1 - \alpha\beta)b \leq (1 - \alpha)\gamma a, \\ (s, f) & \text{if } a \geq 0 \cap (1 - \alpha\beta)b > (1 - \alpha)\gamma a, \\ (f, s) & \text{if } b \leq 0 \cap (1 - (1 - \alpha)\gamma)a < \alpha\beta b, \\ (f, f) & \text{if } a < 0 \cap b > 0. \end{cases} \quad (1.12)$$

Denote

$$\begin{aligned} A_n^{ss} &= \{x \in \mathbb{E} : (1 - (1 - \alpha_n)\beta_n^2)(h_1(n, x) - Tv_{n+1}(x)) \\ &\geq \alpha_n\beta_n^2(H_1(n, x) - Tv_{n+1}(x)), (1 - \alpha_n\beta_n^1)(H_1(n, x) - Tv_{n+1}(x)) \\ &\leq (1 - \alpha_n)\beta_n^1(h_1(n, x) - Tv_{n+1}(x))\} \end{aligned} \quad (1.13)$$

$$\begin{aligned} A_n^{sf} &= \{x \in \mathbb{E} : h_1(n, x) \geq Tv_{n+1}(x), (1 - \alpha_n\beta_n^1)(H_1(n, x) - Tv_{n+1}(x)) \\ &> (1 - \alpha_n)\beta_n^1(h_1(n, x) - Tv_{n+1}(x))\} \end{aligned} \quad (1.14)$$

$$\begin{aligned} A_n^{fs} &= \{x \in \mathbb{E} : H_1(n, x) \leq Tv_{n+1}(x), (1 - (1 - \alpha_n)\beta_n^2)(h_1(n, x) - Tv_{n+1}(x)) \\ &< \alpha_n\beta_n^2(H_1(n, x) - Tv_{n+1}(x))\} \end{aligned} \quad (1.15)$$

and

$$A_n^{ff} = \mathbb{E} \setminus (A_n^{ss} \cup A_n^{sf} \cup A_n^{fs}) \quad (1.16)$$

By the definition of the sets  $A_n^{ss}$ ,  $A_n^{sf}$ ,  $A_n^{fs} \in \mathcal{B}$  and Lemma 1.3.1 we have

$$\begin{aligned} v_n(x) &= [\alpha_n(\beta_n^1(h_1(n, x) - Tv_{n+1}(x)) \\ &+ (1 - \beta_n^1)\beta_n^2(H_1(n, x) - Tv_{n+1}(x))) \\ &+ (1 - \alpha_n)(\beta_n^2(H_1(n, x) - Tv_{n+1}(x)) \\ &+ (1 - \beta_n^2)\beta_n^1(h_1(n, x) - Tv_{n+1}(x)))]\mathbb{I}_{A_n^{ss}}(x) \\ &+ \beta_n^1(h_1(n, x) - Tv_{n+1}(x))\mathbb{I}_{A_n^{sf}}(x) \\ &+ \beta_n^2(H_1(n, x) - Tv_{n+1}(x))\mathbb{I}_{A_n^{fs}}(x) + Tv_{n+1}(x) \end{aligned} \quad (1.17)$$

Define

$$\lambda_n^* = \begin{cases} 1 & \text{if } X_n \in A_n^{ss} \cup A_n^{sf} \\ 0 & \text{otherwise} \end{cases} \quad (1.18)$$

$$\gamma_n^* = \begin{cases} 1 & \text{if } X_n \in A_n^{ss} \cup A_n^{fs} \\ 0 & \text{otherwise} \end{cases} \quad (1.19)$$

The stopping times  $\lambda_n^*$  and  $\gamma_n^*$  are defined by Equations (1.18) and (1.19) with the appropriate  $A_n^\bullet$  given by Equations (1.13) - (1.16).

**Theorem 1.3.2** *Game  $G_A^C$  with payoff function (1.8) and sets of strategies  $\Lambda^N$  and  $\Gamma^N$  available to Player 1 and Player 2 respectively, has an equilibrium pair  $(\lambda^*, \gamma^*)$  defined by Equations (1.18) and (1.19), based on (1.13) - (1.16). The value of the game to Player 1 is  $v_0(x)$ .*

Now we construct an equilibrium pair  $(\psi^*, \tau^*)$  for game  $G^C$ . Let  $(\bar{\lambda}^*, \bar{\gamma}^*)$  be an equilibrium point in  $G_a^C$ .

Define (see [12] and [15])

$$\sigma_{n,m}^{1*} = \begin{cases} 1 & \text{if } S_{N-m}(X_m, X_n) = f(X_m, X_n), \\ 0 & \text{if } S_{N-m}(X_m, X_n) > f(X_m, X_n) \end{cases} \quad (1.20)$$

$$\sigma_{n,m}^{2*} = \begin{cases} 1 & \text{if } S_{N-m}(X_n, X_m) = f(X_n, X_m), \\ 0 & \text{if } S_{N-m}(X_n, X_m) > f(X_n, X_m) \end{cases} \quad (1.21)$$

**Theorem 1.3.3** *Game  $G^C$  has a solution. The equilibrium point is  $(\psi^*, \tau^*)$ , such that  $\psi^* = (\bar{\lambda}^*, \{\bar{\sigma}_n^{1*}\})$  and  $\tau^* = (\bar{\gamma}^*, \{\bar{\sigma}_n^{2*}\})$ .  $(\bar{\lambda}^*, \bar{\gamma}^*)$  is an equilibrium point in  $G_a^C$  and the strategies  $\{\bar{\sigma}_n^{1*}\}$  and  $\{\bar{\sigma}_n^{2*}\}$  are defined by Equations (1.20) and (1.21) respectively. The value of the game is  $v_0(x)$ , where  $v_n(x)$  is given by Equation (1.17).*

Now we consider non-zero sum games. In this case we must search for an equilibrium pair such that

$$\begin{aligned} R_1(x, \bar{\lambda}_{\alpha, \beta^1, \beta^2}(\bar{\lambda}, \bar{\gamma}), \bar{\gamma}_{\alpha, \beta^1, \beta^2}(\bar{\lambda}, \bar{\gamma})) &\leq R_1(x, \bar{\lambda}_{\alpha, \beta^1, \beta^2}(\bar{\lambda}^*, \bar{\gamma}^*), \bar{\gamma}_{\alpha, \beta^1, \beta^2}(\bar{\lambda}^*, \bar{\gamma}^*)) \\ R_2(x, \bar{\lambda}_{\alpha, \beta^1, \beta^2}(\bar{\lambda}^*, \bar{\gamma}), \bar{\gamma}_{\alpha, \beta^1, \beta^2}(\bar{\lambda}^*, \bar{\gamma})) &\leq R_2(x, \bar{\lambda}_{\alpha, \beta^1, \beta^2}(\bar{\lambda}^*, \bar{\gamma}^*), \bar{\gamma}_{\alpha, \beta^1, \beta^2}(\bar{\lambda}^*, \bar{\gamma}^*)) \end{aligned}$$

Let  $v_{1,n}(x)$  ( $v_{2,n}(x)$ ) be the value of this game to the first (second) player on observing the realisation  $x_n$ . The payoff matrix for player 1 is of the same form as the matrix given in Equation (1.10), except that  $v_{1,\bullet}(x)$  replaces  $v_\bullet(x)$ .  $a, b, \alpha, \beta, \gamma$  are defined as before from the matrix given in Equation (1.11). The payoff matrix for the second player has the form

$$\begin{bmatrix} \alpha_n(\beta_n^1 h_2(n, x) + (1 - \beta_n^1)g(n, x, \beta_n^2)) & g(n, x, \beta_n^2) \\ +(1 - \alpha_n)(\beta_n^2 H_2(n, x) + (1 - \beta_n^2)G(n, x, \beta_n^1)) & \\ G(n, x, \beta_n^1) & T v_{2,n+1}(x) \end{bmatrix} \quad (1.22)$$

Subtracting  $T v_{n+1}(x)$  this matrix is equivalent to one of the form

$$A = \begin{bmatrix} \mathbf{a}_{ss} & \mathbf{a}_{sc} \\ \mathbf{a}_{cs} & \mathbf{a}_{cc} \end{bmatrix} = \begin{bmatrix} \alpha(a_2 + (1 - \beta)b_2) & b_2 \\ +(1 - \alpha)(b_2 + (1 - \gamma)a_2) & \\ a_2 & 0 \end{bmatrix} \quad (1.23)$$

By direct checking we have

**Lemma 1.3.4** *The two person game with payoff matrices given by (1.11) and (1.23) has an equilibrium point in pure strategies given by  $(\epsilon, \delta)$ , where*

$$(\epsilon, \delta) = \begin{cases} (s, s) & \text{if } (1 - (1 - \alpha)\gamma)a \geq \alpha\beta b \cap (1 - \alpha\beta)b_2 \geq \gamma a_2(1 - \alpha), \\ (s, f) & \text{if } a \geq 0 \cap (1 - \alpha\beta)b_2 < \gamma a_2(1 - \alpha), \\ (f, s) & \text{if } (1 - (1 - \alpha)\gamma)a < \alpha\beta b \cap b_2 \geq 0, \\ (f, f) & \text{if } a < 0 \cap b_2 < 0. \end{cases} \quad (1.24)$$

There is not necessarily a unique pure equilibrium in the game.

## 1.4 Example

In all the games considered we assume that an applicant accepts a job offer from Player  $i$  with probability  $r_i$ . If both players wish to accept an applicant, then Player 1 has priority with probability  $p$ , otherwise Player 2 has priority. If an applicant rejects an offer from the player with priority, that applicant then accepts the offer from the other player with the appropriate probability. The aim of each player is to employ the best applicant. Thus, the players should only accept applicants, who are the best seen so far (such applicants will be henceforth known as candidates). We obtain asymptotic results for a large number  $N$  of applicants. Let  $t$  be the proportion of applicants already seen.  $t$  will be referred to as the time.

In order to find the equilibrium strategies in the game, we first need to calculate the optimal strategy of a lone searcher. Let  $U_i(t)$  be the probability that Player  $i$  obtains the best candidate, given that he/she is searching alone at time  $t$ . A player should accept a candidate at time  $t$ , iff  $t \geq U_i(t)$ . Smith [12] shows that

$$U_i(t) = \begin{cases} \frac{r_i}{1-r_i}(t^{r_i} - t) & t_i \leq t \leq 1, \\ t_i & 0 \leq t < t_i, \end{cases}$$

where  $t_i = r_i^{1/(1-r_i)}$  satisfies  $t_i = U_i(t_i)$ . Player  $i$ 's optimal strategy is to accept a candidate, iff  $t \geq t_i$ .

**Example 1.4.1 Zero-sum game model** *In this case it is assumed that a player's payoff is 1 if he/she obtains the best candidate, -1 if the other player obtains the best candidate and 0 otherwise. Define  $k_i$  to be the probability that Player  $i$  obtains a candidate when both players wish to accept that candidate. It follows that  $k_1 = r_1[p + (1-p)(1-r_2)]$  and  $k_2 = r_2[(1-p) + p(1-r_1)]$ . Define  $k_3$  to be the probability that neither player obtains a candidate, when both players wish to accept a candidate. Hence,  $k_3 = (1-r_1)(1-r_2)$ . Let  $w(t)$  be the expected value of the game to Player 1 when both of the players are still searching at time  $t$ . Thus  $w(0)$  is the value of the game to Player 1. The payoff matrix on the appearance of a candidate for this game is given by*

$$\begin{pmatrix} k_1[t - U_2(t)] + k_2[U_1(t) - t] + k_3w(t) & r_1[t - U_2(t)] + (1 - r_1)w(t) \\ r_2[U_1(t) - t] + (1 - r_2)w(t) & w(t) \end{pmatrix}.$$

*Rows 1 and 2 (Columns 1 and 2) give the appropriate payoffs when Player 1 (Player 2) accepts and rejects a candidate respectively. The game is solved by recursion. For large  $t$  both of the players to accept a candidate at a Nash equilibrium. From the form of the payoff matrix, both players accepting a candidate forms a Nash equilibrium when the following inequalities are satisfied*

$$\begin{aligned} r_2[U_1(t) - t] + (1 - r_2)w(t) &\leq k_1[t - U_2(t)] + k_2[U_1(t) - t] + k_3w(t) \\ &\leq r_1[t - U_2(t)] + (1 - r_1)w(t). \end{aligned}$$

*Suppose it is stable for both players to accept a candidate if  $t \geq t_{2,2}$ . Considering the distribution of the arrival time of the next candidate, it can be shown*

that

$$w(t) = \int_t^1 \frac{t}{s^2} \{k_1[s - U_2(s)] + k_2[U_1(s) - s] + k_3w(s)\} ds.$$

Dividing by  $t$  and differentiating

$$w'(t) - \frac{(1 - k_3)w(t)}{t} = \frac{k_1}{t^2}[U_2(t) - t] + \frac{k_2}{t^2}[t - U_1(t)].$$

Together with the boundary condition  $w(1) = 0$ , this gives

$$w(t) = C_1 t^{1-k_3} + C_2 t + C_3 t^{r_1} - C_4 t^{r_2},$$

where  $C_3 = \frac{k_2 r_1}{r_2(1-r_1)^2}$ ,  $C_4 = \frac{k_1 r_2}{r_1(1-r_2)^2}$  and

$$\begin{aligned} C_1 &= \frac{(1 - k_3)[k_1 r_2(1 - r_1) - k_2 r_1(1 - r_2)]}{r_1 r_2(1 - r_1)^2(1 - r_2)^2}, \\ C_2 &= \frac{k_2(1 - r_2) - k_1(1 - r_1)}{(1 - r_1)^2(1 - r_2)^2}. \end{aligned}$$

In the case  $r_1 = r_2 = r$  this simplifies to

$$w(t) = \frac{r^2(2p-1)}{(1-r)^3} [(2-r)t^{r(2-r)} - t - (1-r)t^r]. \quad (1.25)$$

In this case (here  $t_2 = t_1$ ), from the symmetry of the game it suffices to consider  $p \geq 0.5$ . Intuitively, for  $p > 0.5$  Player 1 should be the more choosy of the two players. Hence, in this case we look for a Nash equilibrium of the form

$$(\phi^*, \tau^*) = \begin{cases} (a, a) & t \geq t_{2,2}, \\ (r, a) & t_{2,1} \leq t < t_{2,2}, \\ (r, r) & t < t_{2,1}. \end{cases}$$

From the arguments presented above, it follows that  $t_{2,2}$  satisfies

$$(1 + (2p-1)r)[t_{2,2} - U_1(t_{2,2})] = (1-r)w(t_{2,2}). \quad (1.26)$$

It follows from Equation (1.25) that  $w(t) > 0$  for  $t \in [t_{2,2}, 1)$ . Hence, it can be seen that for  $p > 0.5$ ,  $t_{2,2} > t_1$ . For  $p = 0.5$ ,  $w(t) = 0$  on this interval and hence  $t_{2,2} = t_1$ . In this particular case it is simple to show that for  $t < t_1$  both players reject a candidate at a Nash equilibrium. In the more general case, the relation between  $t_{2,2}$  and the optimal thresholds for a lone searcher are not so clear and so henceforth, results are given only in the case  $r_1 = r_2$ . However, the method of solution in the general case is similar.

It can be shown that for  $p > 0.5$  and  $t_{2,1} < t < t_{2,2}$

$$w'(t) - \frac{pw(t)}{t} = \frac{p}{t}[t - U_1(t)].$$

It should be noted here that  $U_1(t)$  changes form at  $t = t_1$ . Considering the payoff matrix  $t_{2,1}$  satisfies  $w(t_{2,1}) = U(t_{2,1}) - t_{2,1}$ . For  $t_1 \leq t \leq t_{2,2}$

$$W(t) = C_5 t^p - \frac{pt^p \ln(t)}{1-p} + \frac{pt}{(1-p)^2},$$

where  $C_5$  is calculated from the boundary condition at  $t_{2,2}$ . Since  $w(t) > 0$  on this interval, it follows that  $t_{2,1} < t_1$ . On the interval  $[t_{2,1}, t_1]$ , we have

$$w(t) = C_6 t^p + t_1 + \frac{pt}{1-p},$$

where  $C_6$  is calculated from the boundary condition at  $t_1$ . For  $t \leq t_{2,1}$  the value function  $w(t)$  is constant. Table 1 gives results for  $p = 1$  (Player 1 always has priority) and various values of  $r$ .

$r$	$t_{2,1}$	$t_{2,2}$	$w(0)$
0.5	0.2139	0.2710	0.0571
0.6	0.2342	0.2995	0.0652
0.7	0.2512	0.3229	0.0716
0.8	0.2654	0.3419	0.0764
0.9	0.2771	0.3568	0.0797
0.95	0.2821	0.3628	0.0807

TABLE 1.1. Numerical Solution of the Bilateral Selection Problem

## References

- [1] R. Bellman. *Dynamic Programming*. Princeton Press, 1957.
- [2] E.B. Dynkin. Game variant of a problem on optimal stopping. *Soviet Math. Dokl.*, 10:270 – 274, 1969.
- [3] E.G. Enns and E. Ferenstein. The horse game. *J. Oper. Res. Soc. Jap.*, 28:51 – 62, 1985.
- [4] E.Z. Ferenstein. Two-person non-zero-sum games with priorities. In Thomas S. Ferguson and Stephen M. Samuels, editors, *Strategies for Sequential Search and Selection in Real Time, Proceedings of the AMS-IMS-SIAM Joint Summer Research Conferences held June 21-27, 1990*, volume 125 of *Contemporary Mathematics*, pages 119 – 133, University of Massachusetts at Amherst, 1992.
- [5] M. Fushimi. The secretary problem in a competitive situation. *J. Oper. Res. Soc. Jap.*, 24:350–358, 1981.
- [6] T. Radzik and K. Szajowski. On some sequential game. *Pure and Appl. Math. Sci.*, 28:51–63, 1988.
- [7] T. Radzik and K. Szajowski. Sequential games with random priority. *Sequential Analysis*, 9(4):361–377, 1990.
- [8] D. Ramsey and K. Szajowski. Random assignment and uncertain employment in optimal stopping of Markov processes. *Game Theory and Appl.*, 7:147–157, 2002.

- [9] G. Ravindran and K. Szajowski. Non-zero sum game with priority as Dynkin's game. *Math. Japonica*, 37(3):401–413, 1992.
- [10] M. Sakaguchi. Bilateral sequential games related to the no-information secretary problem. *Math. Japonica*, 29:961–974, 1984.
- [11] M. Sakaguchi. Non-zero-sum games for some generalized secretary problems. *Math. Japonica*, 30:585–603, 1985.
- [12] M.H. Smith. A secretary problem with uncertain employment. *J. Appl. Probab.*, 12:620–624, 1975.
- [13] K. Szajowski. Uncertain employment in competitive best choice problems. In K.Ano, editor, *International Conference on Stochastic Models and Optimal Stopping, Nagoya 19-21.12.1994*, pages 1–12, Nagoya, Japan, 1994. Faculty of Business Administration, Nanzan University, Nanzan University.
- [14] K. Szajowski. Optimal stopping of a discrete Markov processes by two decision makers. *SIAM J. Control and Optimization*, 33(5):1392–1410, 1995.
- [15] M. Yasuda. On a stopping problem involving refusal and forced stopping. *J. Appl. Probab.*, 20:71–81, 1983.