



Munich Personal RePEc Archive

A dynamic general equilibrium model for tax policy analysis in Colombia

Hernandez, Gustavo Adolfo and Light, Miles and Rutherford,
Thomas

Departamento Nacional de Planeacion, Ministerio de Hacienda
Republica de Colombia

May 2002

Online at <https://mpra.ub.uni-muenchen.de/28435/>
MPRA Paper No. 28435, posted 27 Jan 2011 17:00 UTC

República de Colombia
Departamento Nacional de Planeación
Dirección de Estudios Económicos

ARCHIVOS DE ECONOMÍA

*A dynamic general equilibrium model for tax policy
analysis in Colombia*

Thomas F. RUTHERFORD
Miles K. LIGHT
Gustavo Adolfo HERNANDEZ

Documento 189
15 de Mayo de 2002

La serie ARCHIVOS DE ECONOMÍA es un medio de la Dirección de Estudios Económicos, no es un órgano oficial del Departamento Nacional de Planeación. Sus documentos son de carácter provisional, de responsabilidad exclusiva de sus autores y sus contenidos no comprometen a la institución.

A Dynamic General Equilibrium Model for Tax Policy Analysis in Colombia

Thomas F. Rutherford and Miles K. Light

Economics Department

University of Colorado

Gustavo Hernández*

National Department of Planning

May 10, 2002

Abstract

The paper documents a dynamic general equilibrium model for Colombia based on national accounts from 1999. The paper is part of a project intended to develop a capacity for the the design, specification, and application of computable models within the Colombian Ministry of Finance and Department of National Planning. Our analytical framework includes both forward-looking expectations and Harris-Todaro labor markets. In the present paper we compare numerical results from the dynamic model with simpler static and steady-state formulations to highlight the importance of transitional effects in evaluating tax policy reform. Our applications include measurement of the marginal cost of funds from different tax bases and the evaluation of discrete changes in tariff structure. The structure of the labor and intermediate credit markets have important implications for the ranking alternative tax reform proposals.

*The authors would like to thank Sergio Prada and Juan Mauricio Ramírez from Ministry of Finance and Andrés Escobar, and Ömer Ozak from National Department of Planning for a number of helpful comments. This is a working paper for discussion, the views expressed in this paper are those of the authors and not necessarily those of the Ministry of Finance and National Department of Planning.

1 Introduction

This paper introduces a multi-sectoral, dynamic general equilibrium model for tax policy analysis in Colombia. The model incorporates Harris-Todaro migration and unemployment and two alternative representations of international capital flows, issues which are important considerations for tax reform in developing countries such as Colombia. While the analysis presented in the paper provides policy-relevant insights, the primary objective of the paper is pedagogic. We have developed a template model which can provide a starting point for a variety of future studies of the Colombian tax system.

There are two illustrative calculations reported in this paper. The first compares the marginal cost of funds (MCF) from Colombia's major tax streams. Here we find that one peso of public funds costs 1.2 to 5 or more pesos of foregone current and future consumption, depending on the tax instrument used to raise the revenue, the time horizon of the model, and the labor market formulation. In a second set of illustrative calculations we evaluate two alternative tariff-reform policies. The first policy provides tariff exemptions for capital- and high-tech imports which is intended to foster capital accumulation while the second moves toward a more uniform tariff structure, lowering tariff rates on some goods and raising rates on others. In a second best context, economic theory does not indicate which of these policies would be preferred, but our computable framework indicates that a movement toward uniformity presents substantial efficiency gains while the movement away from uniformity results in a loss of efficiency and fails to promote growth.

We do not put forward these policies as a particular tax reform agenda. Our intent is only to illustrate how the model might be applied to evaluate specific tax reforms. We leave future applications of the modeling framework to specific tax proposals to our colleagues in the Ministry of Finance and the Department of National Planning.

In order to highlight the role of the intertemporal margin on capital taxes, we compare the results from the forward-looking dynamic model with the same policy experiment analyzed in the context of the static and steady-state models.¹ The

¹See Rutherford and Tarr [2001] for a similar analysis for Chile of the differences between policy conclusions based on static and dynamic models.

dynamic model tracks a transition between the short and long-run equilibria. For many experiments, the cost of a distortionary tax policy is larger in a dynamic model than a static model because capital accumulation increases the distortionary effect. Conversely, the transitional impacts are typically smaller than in a steady-state model because the framework accounts for the cost of capital accumulation, while this is only partially accounted for in the steady-state model.

We work in the framework of a classical Ramsey analysis of optimal economic growth with perfect foresight. This is a natural starting point because of the generic representation of financial markets. The model represents an open economy with perfect competition in all markets, a representative consumer, and a constant rate of technological progress. The underlying theoretical model is well studied in the economics literature.² This model is intended to provide a starting point for future quantitative policy analysis, and we therefore have made a number of simplifying assumptions to maintain transparency.

This paper compares results from a collection of related yet distinct models, it is helpful to lay out the logical framework in some detail so that the similarities and differences in model structure are readily apparent. We therefore begin with a schematic overview of the equilibrium structure and benchmark data for the static model.³ Thereafter we lay out the equations which characterize the steady-state and dynamic extensions of the static model. After going through the model formulations, we consider two illustrative applications of the model for policy analysis. Appendices are provided which cover programming details related to the implementation of dynamic models in GAMS/MPSGE and instructions for running the model.

²See, for example, Blanchard and Fischer [1989], and Barro and Sala-i Martin [1995]. The numerical representation of this model is less common in textbooks. See Lau et al. [2002] for an introduction to dynamic equilibrium modeling in a complementarity format. Harrison et al., eds [2000] contains a collection of papers based on policy-oriented dynamic general equilibrium modeling. The present analysis does not address the connection between tariff reform and productivity growth as in Rutherford and Tarr [2002], but such an extension of the present model could be quite useful.

³Algebraic details of the static model are presented in Rutherford and Light [2002]

2 The Static and Steady-State Models

The static model for Colombia represents an Arrow-Debreu economy with constant returns-to-scale and perfect competition. The model is based on 1999 Colombian national accounts which distinguish 16 industries, government, and a single representative household. Equilibrium in this model is characterized by a set of prices and levels of production in each industry such that the market demand equals supply for all commodities. Producers are assumed to maximize profits, there is free entry, and production exhibits constant returns to scale, hence no activity earns a positive economic profit at equilibrium prices. Following Mathiesen (1985) we formulate and solve as a complementarity problem in which three types of equations define an equilibrium: market clearance, zero profit, and income balance.

The relationship between different blocks of a typical model is shown in Figure 1. Taxes are discussed in the next section and therefore, for simplicity, do not appear in this figure.

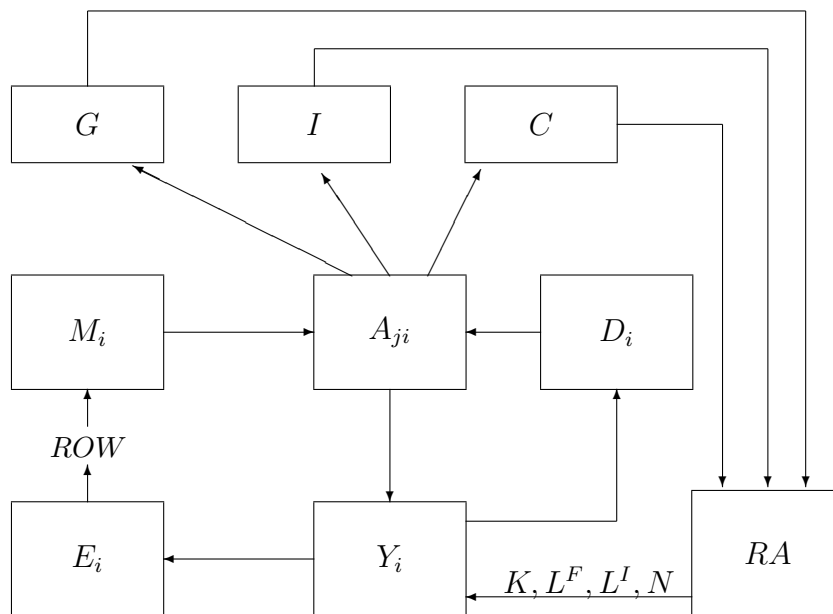

Fig. 1. Flows in a static model

Sector's i output (denoted Y_i) is produced using capital K_i , formal labor L_i^F , informal labor L_i^I , land N , and intermediate inputs described by A_{ji} , an aggregate

of domestic goods D_j and imports M_j . This same composite good enters private consumption C , government consumption G , and investment I . Output from Y_i includes D_i and E_i . A representative agent RA represents a collective decision process for allocating income to households and to a government. The representative agent has an endowment of capital K , two types of labor (L^F and L^I) and tax revenue (not shown). The same consumer demands C, I and G .

Production sector Y_i produces two types of commodities: domestic goods D_i and goods for export E_i . These goods are assumed to be imperfect substitutes, produced with a constant elasticity of transformation. For production, each sector uses capital, labor, land and intermediate goods. As such, the sector's i production function is

$$Y_i = g(D_i, E_i) = f(K_i, L_i^I, L_i^F, N_i, A_{ji}) \quad (1)$$

where g is a constant-elasticity-of-transformation function for outputs, and f is a nested Leontief - Cobb-Douglas production function for inputs. Capital, labor and land enter as a Cobb-Douglas value-added aggregate. Intermediate inputs and the value-added composite enter as a Leontief aggregate at the top level.

The representative consumer demands investment, private and government goods, and receives transfers from the government. In the static model investment is exogenous, while private demand is determined by utility-maximizing behavior. (Consumer utility consists of a Cobb-Douglas utility index defined over Armington aggregations of domestic and imported commodities.) In the static model investment is exogenously fixed. In all the models, the level of public provision is held constant, and all tax policy analysis is undertaken subject to an equal yield constraint. When one tax rate is reduced, another tax flow is increased to compensate for the lost revenue.

Figure 2 provides an overview of the static model structure in which σ signifies an elasticity of substitution and η is the elasticity of transformation.

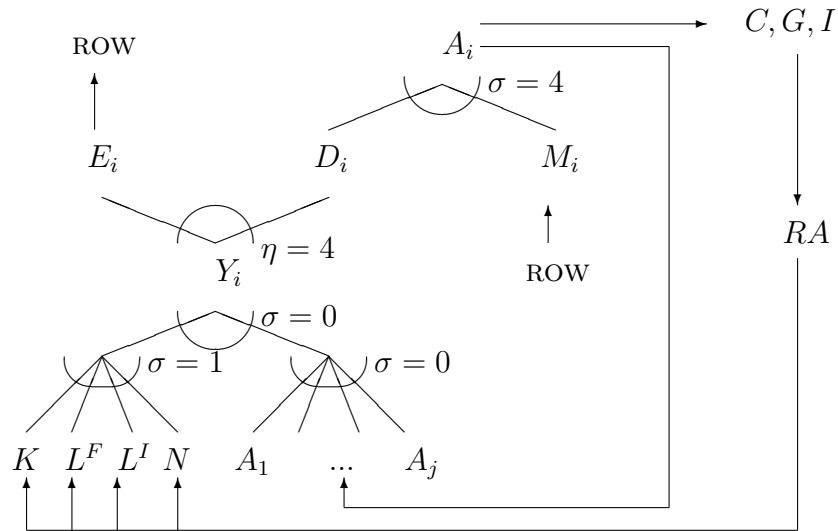

Fig. 2. Structure of the static model

Table 1 presents a perspective on the sectoral shares of economic activity in 1999. Here we see that as in many developing countries, GDP is generated primarily in agriculture, resource-intensive and service sectors. High tech / capital intensive manufacturing accounts for only 3% of value-added but 57% of imports. The key exports in 1999 were agricultural goods plus coffee (25% of export earnings) and oil (22%). Over half of formal labor is employed in service sectors, a third of which is in the public sector. Informal labor is largely employed in agricultural sectors (40%) and private service sector (45%).

The input-output data indicate that capital formation is based on inputs of construction services and high technology/capital-intensive manufactured goods. Final demand is composed of services (33%), foodstuffs (19%) and various manufactured goods (27%).

Table 2 describes the primary factor and trade content of various sectors in the economy. Informal labor earns a relatively large share of aggregate wage payments in agricultural sectors which are highly export-oriented. For example, 69% of wage payments in the coffee sector are to informal workers, and 97% of coffee output is exported.

When we look at trade exposure, we see a few highly export-oriented sectors including oil (77%), other minerals (81%), and coffee (97%). Export shares for manufactured goods range from 16 to 33%, while service sector goods are largely

untraded.

The capital value share column indicates the relative importance of capital in the oil sector (77%) and for selected services (electricity is 71%, communications 65%). The manufactured goods have capital value shares ranging from 20 to 50%.

In the model implementation we include the option to distinguish base year capital earnings between returns to physical capital and returns to sector-specific resources. For example, it would not be appropriate to assume that all capital earnings in the oil sector necessarily accrue to physical capital, otherwise we would be assuming that an expansion of the sector only would require additional oil wells and not new oil fields on which to place the wells. The scenarios described here do not utilize this feature.

Tables 3 and 4 describe the structure of direct and indirect taxes. Table 3 focuses on sectoral tax rates as they apply to value-added, output and inputs. The term “VAT” is used somewhat loosely, as the model and actual application of this tax is on aggregate demand rather than on sectoral value-added. While the posted value-added tax rate is 16%, the base year data suggest that the VAT tax is applied primarily on manufactured goods and communication services. Agricultural products, oil and most services are exempt, yet (as indicated in Table 4), this tax base contributed nearly half of all indirect tax revenues in 1999.

Excise taxes apply on the value of production, both on sales in the domestic economy and on exports. Excise taxes apply at the highest rate on natural resource-intensive manufactures (15%) and coffee (11%). Looking at tax revenue (Table 4), we find that given the relative size of sectors, the single most important indirect tax in the economy is the excise tax on natural resource intensive production, a tax which generated 2.6 billion pesos in 1999.

In 1999 tariffs were applied at a 5% rate on manufactured goods imports and 16% on agricultural goods. In terms of collected revenue, the tariff instrument contributes a relatively small amount, only 11% of all indirect tax revenue.

There are direct taxes in Colombia. The nominal labor income tax is 17%, and the nominal tax on capital gains is 32%. Our base year data indicate, however that the collected rate on formal labor is 4% and the effective capital tax rate is 16%. In the model we assume that informal labor is untaxed.

Table 1: Shares of Economy-Wide Totals (%)

	Value								
	Added	L_F	L_I	K	E	M	G	I	C
Coffee	1	1	4	0	8	0	0	-2	0
Othercrops	7	4	18	0	17	5	0	5	4
Livestock	4	1	13	1	0	0	0	4	1
Forestry and fishing	1	0	2	0	0	0	0	3	0
Oil	4	2	0	5	22	0	0	0	0
OtherMinerals	2	1	3	1	9	0	0	0	0
CoffeeThreshing	0	0	0	0	1	0	0	2	0
Foodstuffs	4	3	3	6	5	4	0	4	19
Natural Resources	4	5	1	3	10	14	0	3	10
Unskilled Intensive	2	3	2	2	7	9	0	4	9
Capital and High Tech	3	3	0	4	14	57	0	29	8
Construction	4	4	1	8	0	0	0	43	0
Transportation	5	7	8	2	3	3	0	0	8
Electricity, Gas, Water	4	3	0	9	0	0	0	0	3
Communications	3	3	0	7	1	1	0	0	4
Private Services	35	27	45	42	1	6	0	6	33
Government Services	17	33	0	10	0	0	100	0	2

Key:

Value Added	Value Added generated in this sector
L_F	Formal labor
L_I	Informal labor
K	Capital earnings
E	Exports
M	Imports
G	Aggregate public expenditure
I	Investment demand
C	Final consumption demand

Table 2: Base Year Value Shares (%)

	L^I	E	M	L	K	Value Added
Coffee	69	97	0	99	1	1
Other crops	71	42	16	98	2	7
Livestock	79	0	0	94	6	4
Forestry and hunting	74	2	3	88	12	1
Oil	0	77	1	23	77	4
Other Minerals	41	81	11	64	36	2
Coffee Threshing	9	32	0	27	73	0
Foodstuffs	20	7	6	52	48	4
Resource Intensive	9	16	19	57	43	4
Unskilled Intensive	28	25	24	79	21	2
Capital Intensive	3	33	56	53	47	3
Construction	7	0	0	48	52	4
Transportation	37	7	6	90	10	5
Electricity and Water	0	0	0	29	71	4
Communications	1	5	3	35	65	3
Private Services	33	1	3	64	36	35
Government Services	0	0	0	82	18	17

Key:

L^I Wage share of informal workers.

E Sectoral output which is exported.

M Sectoral absorption which is imported.

L Labor share of value-added.

K Capital share of value-added.

Value Added Share of economy-wide value-added generated in this sector.

Table 3: Benchmark Tax Rates (%)

	<i>vat</i>	<i>t_y</i>	<i>t_m</i>
Coffee	0	11	0
Othercrops	0	0	16
Livestock	0	0	2
Forestryfishing and hunting	0	0	5
Oil	0	2	0
OtherMinerals	0	0	3
CoffeeThreshing	0	1	0
Foodstuffs	0	2	7
NaturalResources Intensive Industries	6	15	5
UnskilledLabor Intensive Industries	8	2	5
Capitaland High Technology Industries	6	2	5
Construction	0	1	0
Transportation	1	1	0
Communications	15	2	0
Private Services	2	1	1
Government Services	0	1	0

Key:

vat “Value-added tax” applies to all sales of domestic and imported goods .

t_y Excise tax applies to sectoral output (both domestic sales and exports).

t_m Import tariff.

Table 4: Tax Revenue

	<i>vat</i>	<i>t_y</i>	<i>t_m</i>	Total	%
Coffee	0	0.26	0	0.26	2
Other crops	0	0	0.21	0.22	2
Livestock	0	0	0	0	0
Forestry fishing and hunting	0	0	0	0	0
Oil	0	0.12	0	0.12	1
Other Minerals	0	0.01	0	0.01	0
Coffee Threshing	0	0.01	0	0.01	0
Foodstuffs	0.12	0.34	0.09	0.55	4
Natural Resources Intensive Industries	1.41	2.60	0.21	4.21	31
Unskilled Labor Intensive Industries	0.96	0.19	0.14	1.28	9
Capital and High Technology Industries	1.95	0.26	0.82	3.03	22
Construction	0	0.15	0	0.15	1
Transportation	0.07	0.18	0	0.25	2
Electricity Gas and Water	0	0.04	0	0.04	0
Communications	1.06	0.13	0	1.19	9
Private Services	1.00	0.93	0.01	1.93	14
Government Services	0	0.40	0	0.40	3
Total Indirect Revenues	6.56	5.61	1.49	13.66	
%	48	41	11		100
Labor Tax Revenues				2.23	
Capital Tax Revenues				6.95	

Billions of 1999 Colombian Pesos.

2.1 The Steady-State Model

The steady-state model evaluates the long-run impact of a policy change after investment and capital stock have fully adjusted. We assume that for a given rate of return and cost of investment, the capital stock is initially optimal. After a policy reform, the model is based on the presumption that investment and capital stocks readjust to a level which re-equalibrates the present value earnings of a unit of new capital and the cost of a unit of new capital (Tobin's q , the ratio of market value to replacement cost, is equal to unity). For example, a trade reform may lead to a new equilibrium in which the rate of return on capital increases relative to the cost of investment. This implies that in a dynamic sense, a fixed capital stock is no longer optimal for the new equilibrium – investment should be forthcoming until the marginal productivity of capital is reduced to the long run equilibrium where the rate of return on capital is again proportional to the cost of capital.

In a comparative static model we allow the price of capital to vary while holding constant the aggregate stock of capital. The steady-state calculation essentially reverses this: we allow the capital stock (and investment demand) to be endogenously determined while holding constant the price of capital (see Hansen and Koopmans [1972] and Dantzig and Manne [1974]).

Since the steady-state calculation ignores the forgone consumption required to move from the initial capital stock to the new steady-state level, in policy experiments which foster capital accumulation this calculation provides an upper bound on potential welfare gains in a long run classical Solow type growth model. This approach to steady-state evaluation in a multi-regional trade model was implemented in Harrison et al. [1996] and has also been used by Francois et al. [1997].

The steady-state equilibrium is characterized by the static model with an additional variable which represents the equilibrium size of the capital stock. In the benchmark equilibrium, total capital and capital returns are fixed. In the steady-state, κ alters the endowment of physical capital: ⁴

$$\sum_i K_i = \kappa \bar{K},$$

⁴Table 5 provides definitions for the symbols used in this and the subsequent section of the paper.

and investment demand is scaled proportionally:

$$A_i = \sum_j X_{ij}^d + C + G + \kappa a_i^I \bar{I}.$$

Both of these effects enter into the representative consumer's budget constraint:

$$\begin{aligned} & \max \quad U(C) \\ & \text{s.t.} \\ & \quad \kappa r_K \bar{K} + w_I L_i + w_F L_F + \sum_i p_i^N \bar{N}_i + T = \sum_i p_i C_i + \kappa p_I \bar{I} \end{aligned}$$

Let p_I represent the marginal cost of a unit of new investment. In our model this cost function has the form:

$$p_I = \sum_i a_i^I p_i$$

In the steady-state, capital stock adjusts so that the ratio of the rental rate on capital to the cost of producing a unit of the capital good is constant:

$$\frac{r_K}{p_I} = r + \delta$$

implying that in the long-run equilibrium, the return to capital is equal to the sum of the discount rate on future consumption plus depreciation.

2.2 Labor Markets

The base model assumes: (i) labor taxes apply only to formal sector employment, (ii) there is unemployment in the formal sector associated with downward rigidity of the wage rate, and (iii) migration between the formal and informal sectors is driven by both a wage differential and the formal-sector unemployment rate as it affects the probability of an informal worker finding a job in the formal sector, and (iv) labor is measured in the model in efficiency units – in the social accounting framework the labor input is the wage bill, which represents wages plus benefits. We do not attempt to account for differences in per-capita wages across sectors.

The following sets of equations apply in every period t . for notational simplicity the t subscript is suppressed.

The formal-sector unemployment rate is determined by a *wage equation*, in which a wage elasticity parameter, θ , relates the wage rate to the unemployment rate:

$$\frac{w^F}{p^C} = \phi u^{-1/\theta}. \quad (2)$$

In this expression w^F is the formal sector wage rate, p^C denotes a consumer goods price index and u is the formal sector *unemployment rate*, equal to 16% in 1999. In specifying this model θ is specified exogenously, and ϕ is calibrated to match the base year data.

This type of wage equation can be derived from trade union or efficiency wage models (see Hutton and Ruocco [1999]). In our calculations we investigate two alternative specifications of this wage equation, one in which $\theta = 1$ and a second in which $\theta = \infty$.

Following Todaro [1969], we link the formal-informal labor migration rate to the real-wage differential and the rate of unemployment. Migration occurs when the expected real wage for formal employment increases relative to the informal wage. Workers migrate into the formal labor sector until informal wages are equal to *expected* formal wages:

$$w^I = (1 - u) \cdot w^F \quad (3)$$

Labor supply for the formal and informal sectors is determined by the migration rate and the unemployment rate. First, the supply of formal labor is equal to the employed fraction of the workers who chose to migrate to the formal sector:

$$L^F = (1 - u) m \bar{L} \quad (4)$$

where m is the *migration rate* between the informal and formal labor sectors, and \bar{L} is the total workforce. Then the informal labor supply is equal to those workers who did not migrate:

$$L^I = \bar{L}(1 - m) \quad (5)$$

When $\theta = \infty$, the formal sector wage is fixed. In addition to the $\theta = 1$ and $\theta = \infty$ variants of the wage-curve model, we also investigate a flexible wage model in which aggregate employment of formal and informal workers are exogenous and the associated wages adjust to clear each market. The flexible wage model assumes no induced changes in the formal or informal sector unemployment rate as a result of policy measures.

Table 5: Notation for Static and Steady-State Models

Static Model:

i	Sectoral identifier
D_i	Domestic output
E_i	Exports
K_i	Capital stock
L_i^F	Formal labor
L_i^I	Informal labor
A_{ij}	Intermediate demand
Y_i	Aggregate output
C_i	Private demand for i^{th} good
I_i	Investment demand
G_i	Government demand

Steady-State Model:

\bar{K}	Aggregate Capital Stock
κ	Capital stock level in steady-state equilibrium ($\kappa = 1$ in the base year)
\bar{I}	Aggregate base-year investment
a_i^I	Capital formation coefficient - units of good i per unit of aggregate investment ($I_i = \kappa a_i^I \bar{I}$)
r_k	Rental price on physical capital
w^I, w^F	Formal and Informal wage (net of tax)
p_i^N, \bar{N}_i	Price and supply of sector i -specific resources
p_i	Price of a unit of new investment
ρ	Steady-state interest rate
δ	Steady-state depreciation rate
p^C	Aggregate consumption price index
u	Unemployment rate
$u(\cdot)$	Instantaneous utility factor
θ	Formal sector wage-unemployment elasticity
ϕ	Wage-curve scale factor

3 The Dynamic Model

A dynamic model tracks the transition path from the static to the steady-state equilibrium path. The dataset and intra-period model structure are identical to the static model, providing a useful basis for assessing dynamic impacts of tax policy reform. This section describes how capital accumulation and intertemporal consumption are incorporated to extend the static framework.

3.1 Consumer Behavior

The intertemporal utility function of the infinitely lived representative consumer equals the discounted sum of the instantaneous utility of consumption over an infinite horizon:

$$U = \sum_{t=0}^{\infty} \Delta^t U(C_t) \quad (6)$$

In this equation Δ is the single period discount factor, and $U(C_t)$ is defined by the level of consumption and the intertemporal elasticity of substitution (σ):

$$U(C_t) = \frac{C_t^{1-1/\sigma} - 1}{1 - 1/\sigma} \quad (7)$$

The intra-period utility function is identical to the the static and steady-state models, i.e. C_t is a Cobb-Douglas composite:

$$C_t = \prod_i c_{it}^{\alpha_i} \quad (8)$$

The intertemporal and within-period consumption decisions are weakly separable. Thus, given a decision on how much to spend on consumption in any period, the typical static first order condition applies on consumption decisions within each time period. The intertemporal decision is based on the maximization of utility subject to a wealth constraint over the infinite horizon:

$$\begin{aligned} \max \quad & \sum_{t=0}^{\infty} \Delta^t U(C_t) \\ \text{s.t.} \quad & A_0 + \sum_{t=0}^{\infty} (w_t^I L_t^I + w_t^F L_t^F) \sum_i p_{it}^N N_{it+} = \sum_{t=0}^{\infty} p_t^C C_t \end{aligned} \quad (9)$$

The budget constraint contains the value of the initial asset holdings, A_0 . This includes the value of the base year capital stock, $p_0^K K_0$, as well as the net value of asset holdings outside the country. All prices in the budget constraint are defined in present value terms, discounted to period 0 (1999). The present value of wealth includes the value of the entering (period 0) capital stock, the value of sector-specific resource rents, the present value of (formal and informal) wage income and all other taxes and transfers.

3.2 Baseline Growth Path

In order to calibrate the dynamic model, we assume that the economy is initially on the steady-state growth path. This allows us to describe the evolution of capital and labor. A steady-state is defined as a situation in which all quantity variables grow at a constant rate, g and all present-value prices decline with a constant interest rate, r . In this model labor, capital and sector-specific resources are assumed to grow at a constant rate g :

$$L_t = \bar{L}(1 + g)^t, \quad (10)$$

$$N_{it} = \bar{N}_i(1 + g)^t, \quad (11)$$

and the capital evolves through geometric depreciation

$$K_{t+1} = (1 - \delta)K_t + I_t = K_t(1 + g) \quad (12)$$

where I_t is investment and δ is the depreciation rate.

Equation (3.2) implies that on the steady-state growth path $I_t = (g + \delta)K_t$. Investment takes place at a level which covers growth plus depreciation.

When relative factor prices are constant, output for each sector also grows at the same rate g :

$$Y_{it} = \bar{Y}_i(1 + g)^t \quad (13)$$

All future prices (including the price of labor and capital) in terms of present value are:

$$p_{i,t+1} = \frac{p_{it}}{1 + r} \quad (14)$$

3.3 Capital Accumulation

In our dynamic equilibrium framework, there are two prices for capital. p_t^K is the *purchase price* for new capital, and r_t^K is the *rental price* for capital. Total capital returns for a given period, V_t^K are equal to the capital stock times the capital rental rate:

$$V_t^K = K_t \cdot r_t^K. \quad (15)$$

Capital markets are assumed to operate competitively which implies that the period t purchase price for capital equals the period t rental earnings plus the value of the remaining capital sold in the subsequent period:

$$p_t^K = r_t^K + (1 - \delta)p_{t+1}^K. \quad (16)$$

The Euler condition equates the marginal utility of consumption and investment. It implies that the capital purchase price equals $1 + r$ times the current cost of consumption.

$$p_t^K = p_{t-1}^I = (1 + r)p_t^I. \quad (17)$$

Substitution of p_t^K from equation (17) for p_{t+1}^K into (16) defines prices over time. The rental price is for capital in terms of the cost of investment is:

$$r_t^K = (\delta + r)p_t^I \quad (18)$$

This equation states that the steady-state rental price of capital equals the cost of interest and depreciation.

If we observe initial returns to capital as \bar{V}^K from the social accounts for 1999, then the initial level of investment which is consistent with these returns should be:

$$I_0 = \frac{\delta + g}{\delta + r} V_0^K. \quad (19)$$

The 1999 social accounts for Colombia report capital returns and investment as shown in Table 6. This indicates that the base year data are inconsistent with a balanced growth path. At this point, one could *compute* a baseline equilibrium growth path, based on assumptions about future developments in productivity and the transition to a steady state after a given number of years. In order to avoid the complication of collecting baseline growth-path forecasts, in the present analysis

Table 6: 1999 Capital Returns and Investment for Colombia

	Private	Public	Combined
Investment Demand	21.1	-	21.1
Adjusted Investment Demand	25.3	-	25.3
Capital Receipts (V^K)	30.4	3.2	33.7

we have instead chosen to adjust the base year value shares in order to *impose* a steady-state growth path. This approach is advisable during the initial stages of model development in order to simplify testing the model for logical consistency. We leave the construction of a baseline forecast to future model development work.

When adjusting the base year social accounts to achieve steady-state consistency, there are several degrees of freedom in the computation of an aggregate capital stock. The capital stock can be computed based upon either the capital earnings or investment. If we evaluate the capital stock on the basis of returns, with an assumed 5% interest rate and a 7% depreciation rate we find:

$$K_0 = \frac{V^K}{r + \delta} = \frac{(30.4 + 3.2)}{0.05 + 0.07} = 280.7$$

Accordingly, the steady-state investment level is calculated as:

$$I_0 = (g + \delta) K_0 = 25.3$$

In the base-year data we find $I_{1999} = 21.1$, a value nearly 20% lower than that implied under the steady-state assumptions. The fact that 1999 investment is *below* the steady-state level suggests that the economy-wide capital stock is *above* the steady-state level. This seems implausible and leads us to conclude that future model development should more carefully examine the capital earnings data in the social accounts. In Input-Output data, capital returns are often computed as a residual and can deviate substantially from the long-run value shares. We have therefore adjusted investment by solving a least-squares reallocation of investment and consumption demands, subject to the constraint that aggregate investment equals 25.3.

3.4 Financial Capital Flows

An open economy with unrestricted borrowing is characterized by equalization of the domestic and international interest rates. In many countries, this is a counterfactual assumption. In the present model, we explore the role of international financial capital mobility by implementing two alternative representations of the current account constraint.

In the “Balance of Payments” model, the real exchange rate is computed within each period and adjusts to equalize the value of exports and imports in that year. That is:

$$\sum_i \bar{p}_{it}^X X_{it}(\mu_t) = \sum_i \bar{p}_{it}^M M_{it}(\mu_t)$$

where \bar{p}_{it}^X and \bar{p}_{it}^M are the international prices of imports and exports, X_{it} and M_{it} are the trade volumes, and μ_t is the real exchange rate in period t . In this model the domestic interest rate is endogenous, $r_t^D = \mu_{t+1}/\mu_t - 1$.

The “Capital Flows” model allows for net changes to the balance of payments accounts within each period. A single, infinite-horizon intertemporal budget replaces the period-by-period constraints:

$$\sum_{t=0}^{\infty} \sum_i \bar{p}_{it}^X X_{it}(\mu_t) = \sum_{t=0}^{\infty} \sum_i \bar{p}_{it}^M M_{it}(\mu_t) = 0 \quad (20)$$

and the time path of the real exchange rate is determined by the international interest rate:

$$\mu_{t+1} = \frac{\mu_t}{1+r} \quad (21)$$

In the open capital markets model the real exchange rate may adjust only in period 0 following a policy shock.

In the T -period model, the intertemporal trade balance is written:

$$\sum_{t=0}^T \sum_i (\bar{p}_{it}^X X_{it}(\mu_t) - \bar{p}_{it}^M M_{it}(\mu_t)) = A_{T+1} - p_{T+1}^K K_{T+1} \quad (22)$$

where A_{T+1} is the level of terminal assets and K_{T+1} is the terminal capital stock, both of which are approximated as described in the subsequent section.

3.5 Approximating an Infinite Horizon

Approximation of infinite horizon equilibria in this model follows the strategy proposed by Lau et al. [2002]. At an intuitive level, there are two issues in the approximation method. First, we need to choose a terminal (period $T + 1$) capital stock which is consistent with smooth growth in investment in the final periods of the model (*state variable targeting*). Second, we need to determine an estimate of terminal assets which is consistent budget balance and steady-state growth from period T onwards. The terminal asset approximation decomposes the consumer choice problem for the infinitely-lived agent into one choice problem for periods 0 to T , and a second problem from period $T + 1$ to ∞ . An assumption of steady-state growth permits us to solve for period $T + 1$ assets using the budget constraint for the post-terminal utility maximization problem.⁵

Algebraically, the terminal capital stock is determined through two equations. The first is a simple capital stock evolution equation applied to the post-terminal year:

$$K_{T+1} = (1 - \delta)K_T + I_T \quad (23)$$

This constraint is associated with a price variable p_{T+1}^K which rewards investment and depreciated capital carried over to the post-terminal year. The second constraint selects the value of K_{T+1} at a level which assures steady-state growth in the associated control variable in the terminal period:

$$I_T = (1 + g)I_{T-1} \quad (24)$$

This equation replaces the zero profit condition (16) which is associated with capital stocks in the earlier periods of the model.⁶

⁵The determination of a reasonable value of T is based on numerical experimentation. We felt that for the experiments reported in this paper, a 60 year horizon provides a reasonable trade-off between run time and numerical precision. The dynamic model solves in about 5 minutes on a 1.8 GHz PC with an asset approximation error of less than 0.2%.

⁶Equation (24) represents a *primal termination condition*. An alternative approach which may sometimes provide better results is a *dual termination condition*, such as: $p_{T+1}^K = \frac{p_T^K}{1+r}$. This adjusts the terminal capital stock to a level such that the capital price is moving on its steady-state growth path between periods T and $T + 1$. When T is sufficiently long, the model results are virtually identical for either approach.

In a model with international capital flows, the terminal assets of the household need not equal the value of the domestic capital stock, even if these values are equal in the initial year of the model. In order to understand our method of calculating terminal assets, it is helpful to think of the consumer utility maximization problem as two separate optimizations which are linked through the period $T + 1$ assets:

$$\begin{aligned} & \max \quad \sum_{t=0}^T \Delta^t U(C_t) \\ & s.t. \quad A_0 + \sum_{t=0}^T (\sum_i p_{it}^N N_{it} + w_t^I L_t^I + w_t^F L_t^F) = \sum_{t=0}^T p_t^C C_t + A_{T+1} \end{aligned} \quad (25)$$

and

$$\begin{aligned} & \max \quad \sum_{t=T+1}^{\infty} \Delta^t U(C_t) \\ & s.t. \quad A_{T+1} + \sum_{t=T+1}^{\infty} (\sum_i p_{it}^N N_{it} + w_t^I L_t^I + w_t^F L_t^F) = \sum_{t=T+1}^{\infty} p_t^C C_t \end{aligned} \quad (26)$$

Separability of the intertemporal utility means that when A_{T+1} is chosen at the optimal value for the ∞ -horizon program, then the two subproblems together produce a consumption path which is identical to the infinite horizon program.

Suppose that T is chosen to be sufficiently long that the economy is virtually in the steady-state growth path from $T + 1$ onwards. In this case we can use the budget constraint from equation (26) to approximate A_{T+1} :

$$\begin{aligned} A_{T+1} &= \sum_{t=T+1}^{\infty} (\sum_i p_t^C C_t - \sum_i p_{it}^N N_{it} - w_t^I L_t^I - w_t^F L_t^F) \\ &\approx (p_T^C C_T - \sum_i p_{iT}^N N_{iT} - w_T^I L_T^I + w_T^F L_T^F) \frac{1+g}{r-g} \end{aligned} \quad (27)$$

Using a complementarity format permits us to include this constraint in the T -horizon model to simultaneously compute the transition path and determine the terminal asset position.⁷

⁷We do several calculations in the following with an equal yield public sector budget constraint. In these experiments, there is an immediate and permanent change in some set of taxes and we calculate the level of a replacement tax such that the present value of tax revenue over an infinite horizon remains unchanged. For these calculations we use a terminal asset equation for the public sector analogous to the household asset calculation in order to compute changes in tax revenue over the infinite-horizon, including changes induced in year $T + 1$ and thereafter:

$$A_{T+1}^G \approx (p_T^G G_T - T_T^L - T_T^K - T_T^Y - T_T^M - T_T^{vat}) \frac{1+g}{r-g},$$

in which the T_t^k denotes tax revenue from instrument $k \in \{L, K, Y, M, VAT\}$ in period t .

4 Illustrative Applications

We present two sample applications. In the first we estimate the marginal cost of funds (MCF) under alternative model specifications. The objective of this exercise is develop an understanding for the relative importance of labor market and intertemporal features for the MCF. As a second sample application of the model we evaluate a seemingly beneficial proposal to reduce tariffs on High Tech/Capital intensive imports, goods which represent a large share of new investment. The logical appeal of such a policy is that it could promote growth through lowering the cost of capital formation. While the policy proposal seems reasonable and logical, the model reveals that the reasoning is flawed. The numerical model shows that an exemption of tariffs on this sector generates a substantial welfare loss rather than a gain. As an alternative reform, we consider the economic effect of applying a uniform tariff and we find under a wide range of assumptions that this could provide a substantial improvement in growth and welfare.

4.1 The Marginal Cost of Funds

The marginal cost of funds is a computed value which approximates the efficiency cost of increasing public expenditure. This is computed by making a small increase in tax rates and assessing the resulting changes in tax revenue and consumer welfare. We do this calculation in the static, steady-state and dynamic models in order to evaluate the importance of the intertemporal margin. In this analysis, we compare the cost of tax revenue from each of five major revenue sources, t_y , t_m , vat , t_l , and t_k . (See Tables 3 and 4 for the rates and revenue contributions from these tax bases.)

The marginal cost of funds computed in the static, steady-state, and dynamic models are listed in Tables 7, 8 and 9. We calculate the MCF as the total dollar change in Hicksian equivalent variation divided by the total dollar change in government revenues, based on model calculations in which there is a marginal *proportional* increase in the tax base. In the dynamic model we use discounted present values over an infinite horizon to measure both the EV and the change in tax revenue.

Intuitively, the MCF is higher in a the long-run model because capital is no longer a fixed factor. Households have more options to substitute away from taxed goods,

which increases the distortion of a tax. This line of thought is generally consistent with the “Ramsey rule” for optimal taxation [Ramsey 1928], which suggests that taxes are more distortionary as the elasticity of demand increases.

We find that in spite of the labor market impacts, direct taxes on labor are a relatively efficient source of additional revenues. One reason this may be the case for Colombia is that existing effective taxes on labor income are low in our dataset (around 4%).

While the wage tax is relatively efficient, we find that labor market imperfections have a extremely important impact on the estimated MCF, potentially even greater than the intertemporal margin. In the current set of calculations the rigid wage model has an MCF ranging from 8 for the labor tax to infinity for the import tariff.⁸

What are we to conclude from these results?

1. Labor market imperfections could make public funds expensive in Colombia. A more careful assessment of the empirical evidence and appropriate theory which characterize labor markets in Colombia is required before we can assess the MCF with any degree of precision. Empirical estimation of θ is useful and relatively easy to do.
2. A conservative lower bound on the MCF for nearly any of the tax instruments is around 1.5. This has important implications for cost-benefit analysis of public projects in Colombia.
3. MCF estimates based on the static model provide a reasonable tight lower bound on MCF estimates from a dynamic model, and MCF estimates for the steady-state model provide a loose upper bound.

⁸In the rigid-wage, steady-state model, benchmark tariff rates are on the back side of the Laffer curve. A marginal increase in τ^M produces a net *decrease* in tax revenue.

Table 7: MCF Estimates from the Flexible Wage Model

	<i>static</i>	<i>steady</i>	<i>bopcon</i>	<i>capflow</i>
VAT	1.16	1.68	1.24	1.29
TY	1.57	1.78	1.48	1.51
TM	1.78	2.50	1.75	1.82
TL	1.16	1.28	1.11	1.12
TK	1.13	2.69	1.43	1.57

Table 8: MCF Estimates from the Wage Curve Model ($\theta = 1$)

	<i>static</i>	<i>steady</i>	<i>bopcon</i>	<i>capflow</i>
VAT	1.30	2.18	1.51	1.60
TY	1.83	2.23	1.78	1.83
TM	2.08	3.38	2.19	2.32
TL	1.38	1.68	1.37	1.40
TK	1.11	3.50	1.65	1.90

Table 9: MCF Estimates from the Rigid Wage Model ($\theta = \infty$)

	<i>static</i>	<i>steady</i>	<i>bopcon</i>	<i>capflow</i>
VAT	2.15	16.25	4.16	5.93
TY	4.12	18.78	5.51	7.24
TM	5.16	∞	11.76	30.11
TL	2.81	8.10	3.86	4.63
TK	1.03	146.54	3.22	6.01

4.2 Evaluating a Tariff Reform Proposal

A common policy goal for developing countries is increased capital formation and GDP growth. Examining Table 2, it might seem that one means of encouraging capital formation would be to lessen the tariff burden on goods which are used intensively in investment. The base year statistics indicate that capital/high tech goods (HTC) comprise 29% of investment and 57% of HTC supply was imported in 1999.

While the tariff rate on capital imports is only 5%, it seems (ex-ante) plausible that eliminating this tariff might expand growth. The benefits of lowering this tax must be considered in light of the costs related to raising revenues from other sources. Tariff revenues from HTC imports were 0.82 billion Colombian pesos in 1999, just over half of total tariff revenues.

When we compute the comparative dynamic growth path in the model with free capital flows, we find that eliminating the HTC nearly eliminates the domestic HTC industry, particularly when the tariff is replaced by an increase in value-added taxes. Figure 1 indicates that there a slight positive impact on investment when revenues are replaced using an excise or labor tax, but the net impact is negative when the lost tariff revenue is recovered through value-added taxes. The degree to which investment is adversely affected also depends on financial capital flows. When there is unrestricted access to international credit markets, high-technology imports are rapidly substituted for domestically produced HTC goods. In the model with period-by-period trade balance constraints, the decline of domestic HTC production takes place over many more years.

The tariff policy is shown to reduce the rate of domestic investment, but it is not completely clear why investment falls. Figure 2 helps diagnose these results. Here we have shown the *absolute* declines in capital demand for those sectors that experience a fall in capital use. Here we see that HTC itself is responsible for the fall in investment: HTC import competition drives down the demand for domestic HTC, and this leads to a decrease in the HTC demand for capital. The tariff makes investment less expensive, but cripples the domestic industry which is most capital intensive.

Figure 1 indicates that revenue recycling through the existing excise taxes or the

labor tax could lead to an increase in investment, yet Figure 3 shows that no matter which replacement tax is applied, the tariff exemption for HTC is welfare worsening. The least adverse impact is in the balance of payments constrained case, where the balance of payments constraint limits HTC import substitution. This implies that it takes time for the policy to have an adverse impact.

The final figure, Figure 4, indicates that a movement toward tariff uniformity is more beneficial than piecemeal tariff exemptions. In this scenario, a uniform 4% tariff achieves an equal yield with no change in other domestic taxes. These results are consistent with findings from previous work in Chile [Harrison et al. 2002] as well as the theoretical literature [Hatta 1977].

Figure 1: Investment Response (% change)

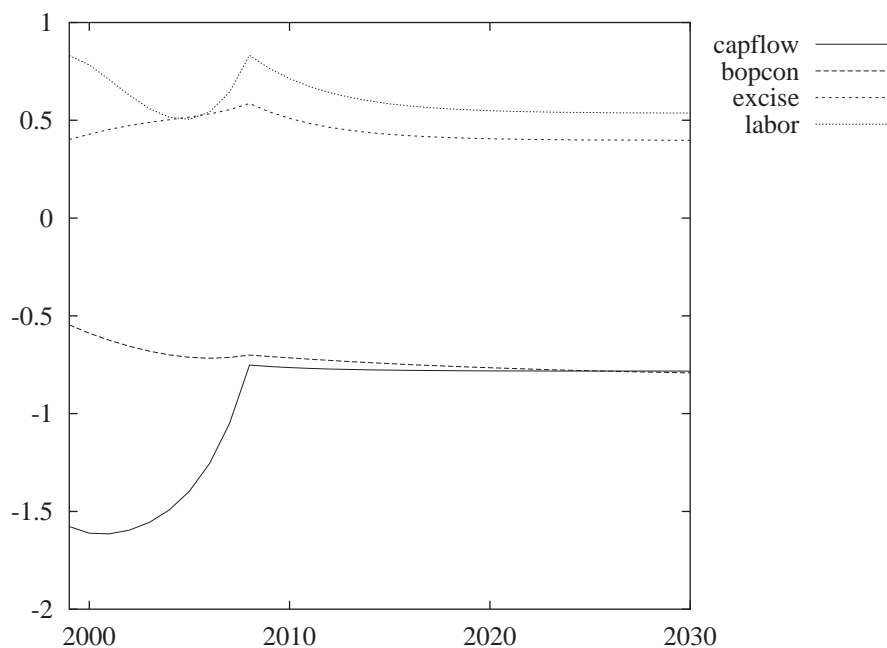

Policy: Permanent elimination of the tariff on high-technology and capital-intensive goods in 1999.

Key:

- capflow Unrestricted capital flows at international interest rates. (revenue replacement: VAT)
- bopcon Period-by-period balance of payments constraints and endogenous domestic interest rate. (Revenue replacement: VAT)
- excise Unrestricted capital flows at international interest rates. (Revenue replacement: TY)
- labor Unrestricted capital flows at international interest rates. (Revenue replacement: TL)

Figure 2: Change in Sectoral Capital Demand (%)

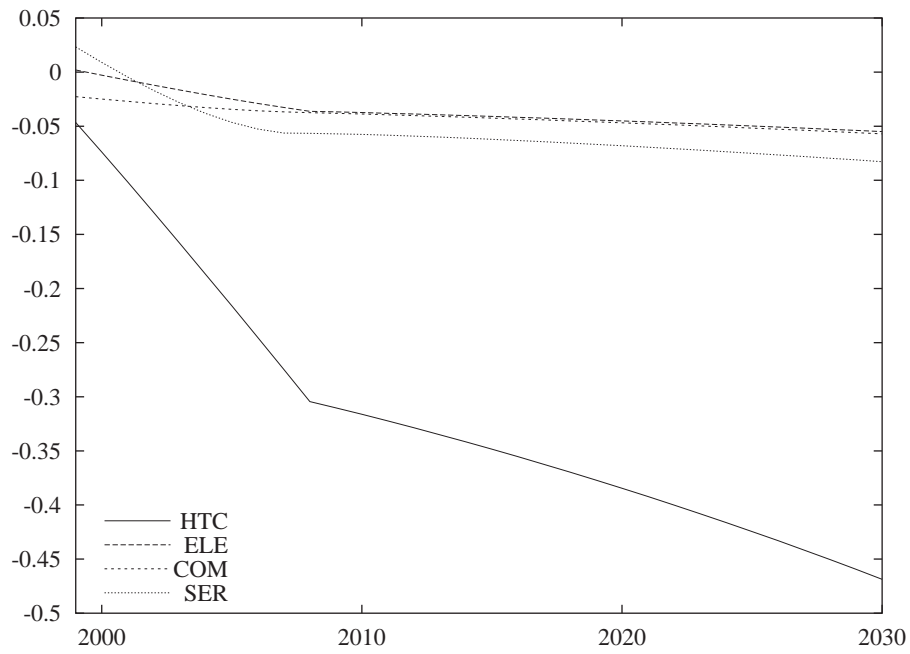

Policy: Permanent elimination of the tariff on high-technology and capital-intensive goods in 1999.

Key:

- HTC Capital and High Technology Industries
- ELE Electricity, Gas and Water
- COM Communications
- SER Private Services

Figure 3: Consumption Response (% change)

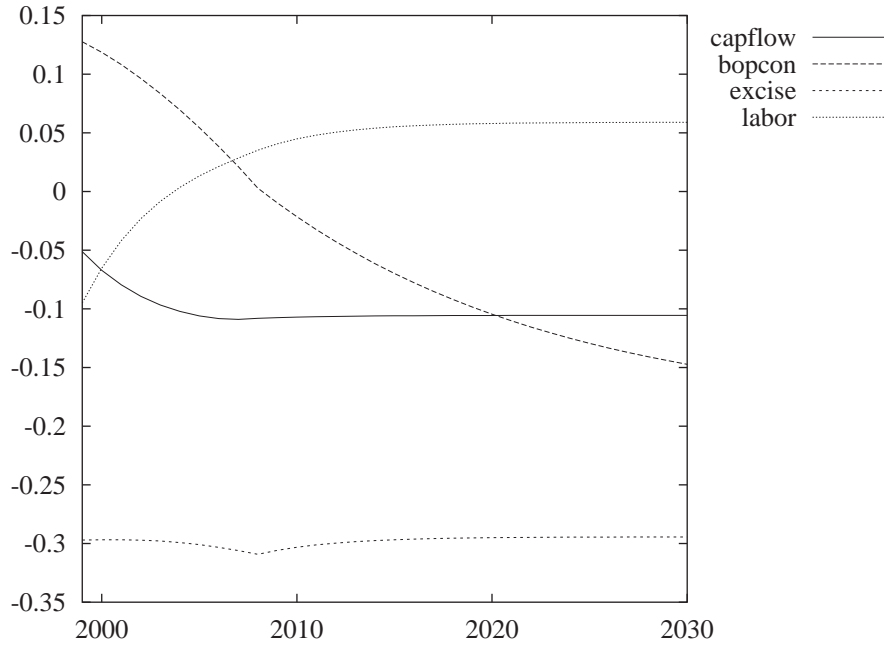

Policy: Permanent elimination of the tariff on high-technology and capital-intensive goods in 1999.

Key:

- capflow Unrestricted capital flows at international interest rates. (revenue replacement: VAT)
- bopcon Period-by-period balance of payments constraints and endogenous domestic interest rate. (Revenue replacement: VAT)
- excise Unrestricted capital flows at international interest rates. (Revenue replacement: TY)
- labor Unrestricted capital flows at international interest rates. (Revenue replacement: TL)

Figure 4: Consumption Response (% change)

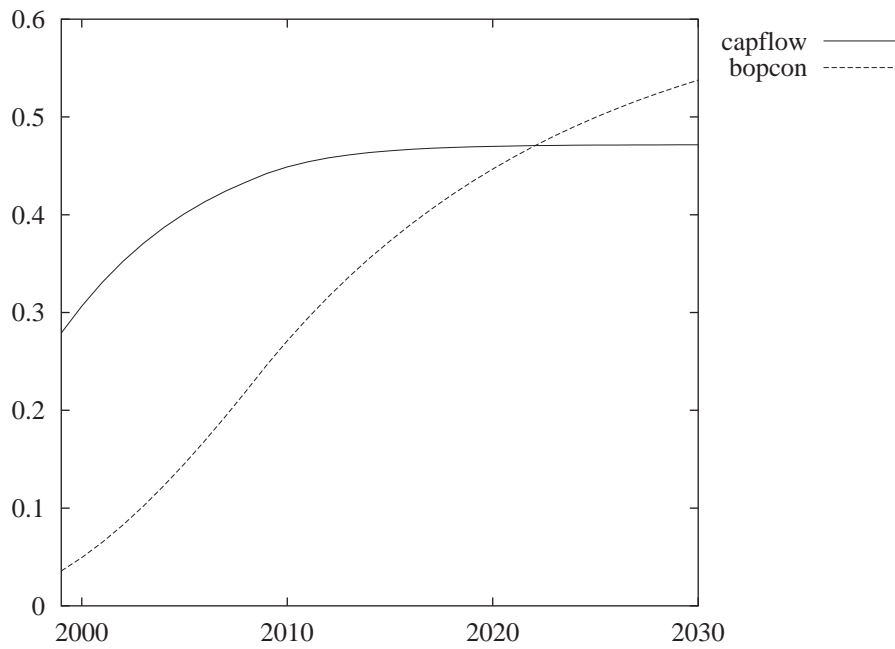

Policy: Permanent application of a uniform tariff on all imports in 1999 at a 4% level which produces no change in government tax revenue.

Key:

capflow Unrestricted capital flows at international interest rates.
bopcon Period-by-period balance of payments constraints and endogenous domestic interest rate.

5 Conclusions

We use this section to reflect on aspects of the modeling work which are not emphasized in the paper

Data Work Substantial effort and experience were leveraged to construct and interpret the base year data for use with a CGE model. In many cases, this work is far more difficult than the actual implementation of the model equations. Although the present paper does not emphasize data issues, we caution the reader not to discount the difficulty and importance of this type of work.

Tax Interpretation The representation of tax margins in the current analysis is stylized. We have identified the key components of the direct and indirect taxes, but we have not attempted to characterize differences between the average and marginal rates nor have we considered the costs of collection or rates of evasion. Informed adjustments of the tax margins could alter the MCF estimates and could conceivably alter our policy analysis conclusions. More work is clearly warranted in this area.

Programming Details Model implementation issues have been only mentioned in the appendices describing operational details. There are a number of subtleties involved in the implementation of multisectoral, dynamic general equilibrium models. We rely heavily on the GAMS/MPSGE programming language for model specification (see Rutherford [1999]) and the PATH solver (see Ferris and Munson [2000]).⁹ Use of GAMS/MPSGE greatly reduces the scope for programming errors, as we avoid writing out cost functions, expenditure functions and demand functions. The disadvantage of the MPSGE approach is that this makes the model less accessible for economists who are unfamiliar with the syntax. It could be helpful to produce an algebraic implementation of the same model using GAMS/MCP, if only to provide a transparent and comprehensive documentation of the model inputs and assumptions.

⁹This is not a particularly large model for PATH. The transitional dynamic model with annual time periods through 2060 involves roughly 5000 variables with a nonlinear system of equations whose sparse Jacobian is 0.28% dense. A typical scenario solves on a PC in under a minute.

5.1 Further Research

We can envision a number of interesting directions in which the current model might be extended. We will list some of the ideas in random order:

Taxation and violence. The present model does not address the economic effects of sabotage and guerrilla activities which have severely disrupted a number of important economic activities in the country. Future application of the model might attempt to quantify the economic gains which could be realized through achieving a lasting solution to the current civil unrest.

Property rights, idle capital and growth. de Soto [2001] provides an interesting new perspectives on the role of property rights in the development process. Our dynamic model incorporates forward-looking markets with price-responsive investment and could be calibrated to account for differences between the market and private return to capital. It could be intriguing to see if the model might be extended to quantify some of the market imperfections which DeSoto has emphasized.

International trade. The present model is based solely on national accounts for Colombia and does not incorporate bilateral trade data. It would be interesting to extend the model to provide a tool for examining the economic effects of FTAA accession or other regional trading agreements. A natural strategy for such an extension would be to build on the GTAP dataset and framework.

Tax reform and poverty. There is a 1997 SAM which provides much more sectoral and household detail. It would be quite interesting to investigate *both* efficiency and equity using the household data from this source. Clearly, there is a link between rural poverty and violence, and given the adverse impact of violence on growth, there is a clear need for tools which can evaluate the distributional consequences of tax reform.

References

- Barro, Robert J. and Xavier Sala i Martin**, *Economic Growth*, New York: McGraw-Hill, 1995.
- Blanchard, Olivier J. and Stanley Fischer**, *Lectures on Macroeconomics*, Cambridge: MIT Press, 1989.
- Dantzig, George B. and Alan S. Manne**, “A Complementarity Algorithm for an Optimal Capital Path with Invariant Proportions,” *Journal of Economic Theory*, 1974, 9 (3), 312–323.
- de Soto, Hernando**, *The Mystery of Capital* 2001.
- Ferris, Michael C. and Todd S. Munson**, “Complementarity Problems in GAMS and the PATH Solver,” *Journal of Economic Dynamics and Control*, 2000, 24 (2), 165–188.
- Francois, Joseph F., Bradley J. McDonald, and H. Nordström**, “Capital Accumulation in Applied Trade Models,” in Richard Baldwin, ed., *Dynamic issues in applied commercial policy analysis: A handbook*, Cambridge University Press, 1997.
- Hansen, Terje and Tjalling Koopmans**, “On the Definition of Computation of a Capital Stock Invariant under Optimization,” *Journal of Economic Theory*, 1972, 5 (3), 487–523.
- Harrison, Glenn W., Svend E. Hougaard Jensen, Lars H. Pedersen, and Thomas F. Rutherford**, eds, *Using Dynamic General Equilibrium Modeling for Policy Analysis*, Amsterdam: North-Holland, 2000.
- , **Thomas F. Rutherford, and David G. Tarr**, “Increased competition and completion of the market in the European Union: static and steady-state effects,” *Journal of Economic Integration*, 1996, 11 (3), 332–365.
- , — , and — , “Trade Policy Options for Chile: The Importance of Market Access,” *The World Bank Economic Review*, 2002. Forthcoming.

- Hatta, Tatsua**, “A Theory of Piecemeal Policy Recommendations,” *Review of Economic Studies*, 1977, 44 (1), 1–21.
- Hutton, J. and Anna Ruocco**, “Tax Reform and Employment in Europe,” *International Tax and Public Finance*, 1999, 6, 263–288.
- Lau, Morten I., Andreas Pahlke, and Thomas F. Rutherford**, “Approximating infinite-horizon models in a complementarity format: a primer in dynamic general equilibrium analysis,” *Journal of Economic Dynamics and Control*, 2002, 26, 577–609.
- Ramsey, Frank**, “A Mathematical Theory of Saving,” *Economic Journal*, 1928, 38, 543–559.
- Rutherford, Thomas F.**, “Applied General Equilibrium Modeling with MPSGE as a GAMS Subsystem: An Overview of the Modeling Framework and Syntax,” *Computational Economics*, 1999, 14, 1–46.
- and **David G. Tarr**, “Regional Trading Arrangements for Chile: Do the Results Differ with a Dynamic Model?,” Working Paper, The World Bank 2001.
- and —, “Trade liberalization, product variety and growth in a small open economy: a quantitative assessment,” *Journal of International Economics*, 2002, 56, 247–272.
- and **Miles K. Light**, “A General Equilibrium Model for Tax Policy Analysis in Colombia,” Working Paper 22, Department of National Planning 2002.
- Todaro, Michael P.**, “A Model for Labor Migration and Urban Unemployment in Less Developed Countries,” *American Economic Review*, 1969, 59 (1), 138–148.

A Running the Model

The dynamic **MegaTax** model is programmed in GAMS/MPSGE. The model files are organized in a directory structure, and the model is designed to run from a DOS command line. In this portion of the appendix, we describe the file structure and some built-in options for running the CGE models.

The models, data, and documentation are included in the compressed archive called **dynamicmega.zip**. When decompressed, this archive builds the following set of directories:

4-08-2002	10:22p	<DIR>	data
4-08-2002	10:22p	<DIR>	model
4-08-2002	10:24p	<DIR>	policy
4-08-2002	10:22p	<DIR>	mcf

The subdirectories are organized as follows:

Directory	Description
data	Contains original source data files (.xls format) and associated data-handling routines
model	Contains the static and dynamic models.
mcf	Contains batch files, GAMS programs and results from the calculations of the marginal cost of public funds described in section 4.1 of this paper.
policy	Holds batch files, GAMS programs and results from policy analysis scenarios described in section 4.2 of this paper.

Scenario management with computational models can present programming challenges. The model structure adopted here is intended to facilitate the comparison of model output across a set of alternative assumptions. We suggest an incremental approach to learning how to use the model. While the directory structure contains a subdirectory for calculations of the marginal cost of funds, in this appendix we focus on the policy-oriented use of the model (the **policy** directory).

We present the following sequence of tasks intended to introduce a new user to the application of the model for policy analysis. We assume that model users are familiar with a text editor which is able to read and write ASCII text files.¹⁰

A.1 Working with Existing Scenarios

A policy scenario is defined by an identifier (10 characters or less, no embedded blanks) and a set of assumed values for the model run parameters. For example, we have pre-defined a policy scenario called `utm_cf`, which imposes uniform tariffs in the dynamic model and assumes that international capital flows are unrestricted. Table 10 describes each of the pre-defined scenarios in the `DynamicMega` distribution.

Tools for making figures and tables are also included in the `policy` directory as `table.bat` and `figure.bat`. Using these batch files can seem awkward at first, but they offer a structured approach for managing policy scenarios.

A.1.1 Creating Tables

`table.gms` is a GAMS program designed to produce tables which compare two or more scenarios, side by side. Commonly-used output parameters have already been defined in `table.gms`, such as output, international trade and consumption. `table.gms` is called from the `table.bat` control program. The main idea behind using batch files is to allow a command-line interface for GAMS, where scenario choices can be easily changed and viewed.

Syntax:

```
table.bat {output parameter} {scenario1 [scenario2...]}
```

Output Parameters: Currently, there are four output parameters for use with `table.gms`. Additional output parameters can be included directly into the `table.gms` file.

`table.gms` Pre-defined Output Parameters:

¹⁰Three text editors are included with Windows, including Notepad, Wordpad and Edit. We feel that these programs are inferior to a number of publically available alternatives such as MetaPAD, NTEmacs, WinEdit or NotGNU.

Table 10: Presolved Policy Scenarios

Identifier	Description	
utm_cf	policy=utm horizon=capflow	Uniform tariffs in the dynamic model with unrestricted capital flows (open capital markets).
utm_bp	policy=utm horizon=bopcon	Uniform tariffs in the dynamic model with period-by-period balance of payments constraints (closed capital markets).
utm_st	policy=utm horizon=static	Uniform tariffs in the static model
utm_ss	policy=utm horizon=steady	Uniform tariffs in the steady-state model
htx_cf	policy=utm horizon=capflow	Free trade in high tech goods in the dynamic model with unrestricted capital flows (open capital markets).
htx_bp	policy=exempt horizon=bopcon	Free trade in high tech goods in the dynamic model with period-by-period balance of payments constraints (closed capital markets).
htx_st	policy=exempt horizon=static	Free trade in high tech goods in the static model
htx_ss	policy=exempt horizon=steady	Free trade in high tech goods in the steady-state model

<code>output</code>	Sectoral Production (% change)
<code>import</code>	Imports by sector (% change)
<code>export</code>	Exports by sector (% change)
<code>results</code>	Summary results for several key economic metrics, such as Equivalent Variation, Formal and Informal Wages, and Return to Capital

How data flows between batch files and GAMS programs is initially confusing. The typical structure for making a table across scenarios is shown in the diagram below.

table.bat and Related Files

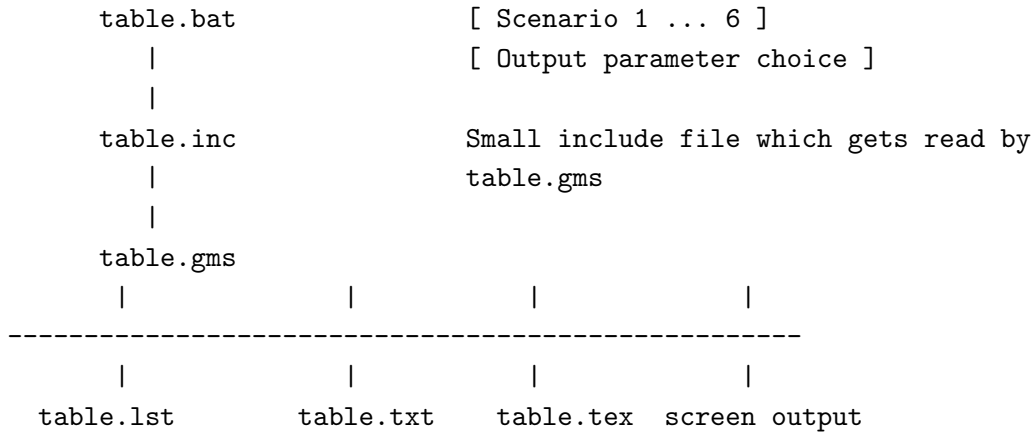

`table.bat` is used to define which parameters to compare and which scenarios to consider. A small file, `table.inc`, is written to be included into `table.gms`, which produces tables using the `gams2tbl` libinclude utility.

Example: *Import Comparisons*

As an example, we compare the change in imports for Colombia across two tariff reform scenarios: `ss_utm` and `st_utm`. First, connect with the `policy` sub-directory in the `DynamicMega` distribution, then execute the following command:

```
c:\model\policy>table.bat import ss_utm st_utm
```

This calls `table.bat` from the `policy` directory, which passes the output parameter and the scenarios to `table.gms`. The table is printed in three ways: to the screen for quick viewing, to a text file, and to a file which can be read by `LATEX`.

The text version of the corresponding output table is:

Imports (% change)		
	st_utm	ss_utm
CRO	71.1	72.9
LVS	-23.1	-22.4
FFH	-2.9	-2.4
OIL	-31.0	-31.0
MIN	-11.8	-10.2
FOD	13.4	12.5
NRI	0.6	1.8
NSI	-0.5	-1.4
HTC	-0.2	-0.1
TRN	-30.3	-31.0
ELE	-32.0	-34.1
COM	-30.8	-33.8
SER	-29.2	-30.8

A.1.2 Creating Figures

We use `GNUPlot` to generate figures for the dynamic model. The approach is similar to creating tables, where we define the scenarios to compare and the parameter for comparison. Some parameters have already been defined in `figure.gms`, they are listed below.

Pre-defined Plotting Parameters for use with `figure.gms`:

<code>pctev</code>	Percentage equivalent variation
<code>wage_f</code>	Formal wage
<code>wage_i</code>	Informal wage
<code>rent</code>	Rental rate for capital
<code>rexch</code>	Real exchange rate
<code>lsup_f</code>	Labor supply – formal
<code>lsup_i</code>	Labor supply – informal
<code>pctinv</code>	Investment
<code>capital</code>	Capital stock
<code>consum</code>	Consumption

The file structure for `figure.bat` is similar to `table.bat`. Data flows through the following files:

figure.bat and Related Files

<code>figure.bat</code>	[Scenario 1,2,.. (up to 6)] [Output parameter choice]
<code>figure.inc</code>	Small include file which gets read by <code>figure.gms</code>
<code>figure.gms</code>	Passes data to GnuPlot for plotting [gp_opt Options can be included for fine-tuning]
<code>gnuplot</code>	Produce the plot
<code>plot</code>	Resulting figure, to the screen or to an output file (.gif or .eps)

Example: *Role of Capital Flows*

A new figure is created by calling `figure.bat` with options which choose the scenarios and output parameter:

```
c:\model\policy>figure pctinv bp_utm cf_utm
```

This command plots the percentage change in investment for two scenarios: uniform tariffs with closed capital markets, and uniform tariffs with open capital markets. The resulting plot is shown in Figure 5.

Figure 5: Scenario Comparison Using `figure.bat`

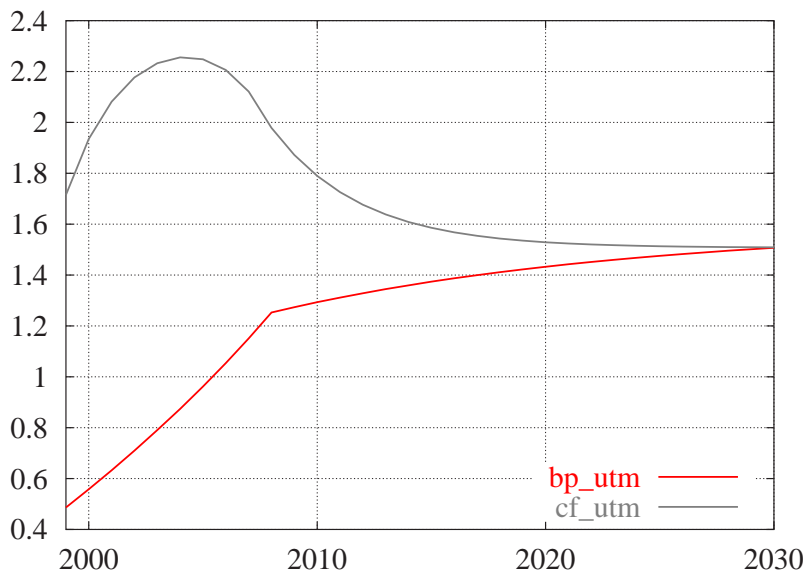

A.2 Defining New Scenarios

Inevitably, new scenarios will be needed as new policy decisions arise. A new set of scenarios can be created created by changing the default `$setglobal` (input) variables and giving the scenario a name. All of the pre-defined `$setglobal` input choices are listed in Table 11. When adding new sets of scenarios, we recommend copying the `policy` directory and renaming it according to the new set of scenarios. These new scenarios are created for new policy considerations, or to conduct sensitivity analysis for existing policies. As an example, we compare the uniform tariff experiment across different elasticity choices.

Example: *Change Existing \$setglobals*

First, we create a new directory and name it *sensitivity*. Then we copy all of the

Table 11: Model Input Parameters for the Static and Dynamic MEGA Models

Variable	Default	Description
<code>policy</code>	<i>blank</i>	Trade policy option: <code>utm</code> for uniform tariff or <code>exempt</code> for tariff exemptions applied to capital-intensive and high-tech goods.
<code>horizon</code>	<code>static</code>	Model time horizon, one of four options: <code>static</code> , <code>steady</code> , <code>bopcon</code> , and <code>capflow</code> . The <code>bopcon</code> formulation is based on the dynamic model with closed capital markets (balance of payments constraints), and <code>capflow</code> is based on the dynamic model
<code>LabMarket</code>	<code>HT</code>	Labor market formulation. <code>HT</code> refers to the Harris-Todaro model with unit elasticity wage-unemployment curve in the formal sector. <code>HTU</code> describes Harris-Todaro with a fixed formal sector wage and classical unemployment, <code>Flexible</code> refers to a neoclassical labor market with flexible wages and fixed supply of both formal and informal labor.
<code>etrndx</code>	2	Output elasticity of transformation between domestic and export markets.
<code>esubt</code>	0.5	Intertemporal elasticity of substitution.
<code>esubdm</code>	4	Armington elasticity between domestic and imported goods.
<code>esubkl</code>	1	Elasticity between labor and capital in production.

scenario files from *policy* into the new directory. This is done from the command prompt, in the top-level (model) directory.

```
c:\model>mkdir sensitivity
c:\model>copy policy\*.* sensitivity
```

Now, edit the batch file called: `solves.bat` to define a new set of scenarios to solve. Delete the old *SOLVE* statements and consider the following solves:

```
CALL SOLVE arm_low_st    esubdm=0.5    u_tm=yes horizon=static
CALL SOLVE arm_med_st    esubdm=8      u_tm=yes horizon=static
CALL SOLVE arm_hi_st     esubdm=16     u_tm=yes horizon=static
CALL SOLVE ht_off        u_tm=yes horizon=static ht=no
CALL SOLVE ht_on         u_tm=yes horizon=static
```

Notice that all of the scenario names are *less-than* 10 elements. Longer names will cause an error in GAMS.

With the newly defined scenarios, we can simply call the `solve.bat` command file and run all of the scenarios:

```
c:\model\sensitivity>solves.bat
```

Once the scenarios have been solved, we make a table to quickly compare the results:

```
c:\model\sensitivity>table.bat results arm_low_st arm_med_st arm_hi_st ht_off ht_on
```

The resulting table (in L^AT_EX format) looks like this:

Summary results					
	arm_low_st	arm_med_st	arm_hi_st	ht_off	ht_on
REXCH	0.1	0.2	0.4	0.1	0.2
PCTEV	0.0	0.3	0.8	0.3	0.3
RENT	0.0	1.0	2.2	0.9	1.0
LSUP_F	0.0	0.5	1.1	0.3	0.5
LSUP_I	0.0	-0.7	-1.6	-0.5	-0.7
WAGE_F	0.0	0.0	0.1	0.2	0.0
WAGE_I	0.0	0.0	0.1	-0.2	0.0

It is clear from the sensitivity analysis that the Armington elasticity of substitution between domestic and imported goods will drive welfare and labor results. We also see that migration and unemployment are less important when considering tariff reform in the static framework than in the steady-state model.

Example 2: *Change the default model.* This example shows you how to change the default model specification, then re-run all of the given scenarios. This makes use of the `model.gms` file included in the `policy` directory. The `model.gms` file defines all of the available `setglobal`s for a given scenario folder. For example, the `sensitivity` folder contains the following `model.gms` file:

model.gms:

```

$if not setglobal horizon $setglobal horizon static
$if not setglobal u_tm $setglobal u_tm no
$if not setglobal htft $setglobal htft no
$if not setglobal ht $setglobal ht yes
$if not setglobal theta $setglobal theta 1

$if not setglobal esubt $setglobal esubt 0.5
$if not setglobal etrndx $setglobal etrndx 4
$if not setglobal esubdm $setglobal esubdm 8
$if not setglobal esubkl $setglobal esubkl 1

$if %horizon%==capflow $include ..\model\dynamic
$if %horizon%==bopcon $include ..\model\dynamic
$if %horizon%==static $include ..\model\static
$if %horizon%==steady $include ..\model\static

$if %horizon%==capflow $include dynamic-scenarios.gms
$if %horizon%==bopcon $include dynamic-scenarios.gms
$if %horizon%==static $include static-scenarios.gms
$if %horizon%==steady $include static-scenarios.gms

```

The default values for each input variable is set at the top. The bottom section simply directs the solver to the relevant GAMS model. For example, if the `horizon=capflow`, then the dynamic model is used instead of the static model.

For example, change the default wage-curve elasticity to a low number in `model.gms`:

```
$if not setglobal theta    $setglobal theta 0.2
```

Now, empty the output directory and resolve all of the cases:¹¹

```
c:\model\sensitivity>del output\*
c:\model\sensitivity>solves.bat
```

Now check to see if the Harris-Todaro formulation has a more dramatic impact under the Uniform Tariff reform by calling the `table.bat` command for each of the scenarios. The corresponding table for this model is:

A.3 Create a New `$setglobal` Option

Global variables can be created anytime a new type of model control is needed. Initially, it may seem that global variables are un-necessary to control model inputs. It would be easier for the modeler to simply enter the new input values into the model file by hand. Directly changing parameter values or model structure is fine for small problems and simple counterfactual analysis, but this approach soon becomes unwieldy. Common errors (by at least one of the authors) include forgetting to reset a switch when producing different figures, or accidentally re-setting a parameter before reporting it.

When a new policy variable is needed, create it using a `$setglobal` variable, which includes a default value. In this way, counterfactual scenarios can be traced back to the `model.gms` file or the `scenario` file used to generate it. The extra effort of using a `$setglobal` is rewarded with consistent scenario management.¹²

Example: *Develop a uniform VAT switch*

As an exercise, we will consider uniform value-added taxes in the static, steady-state, and dynamic models. We will define a `$setglobal` variable which equalizes

¹¹Deleting the existing solution files is important. The batch files check for existing solves with the same name. If an identical `.sol` already exists, then the program skips that scenario to save time.

¹²For a detailed discussion of scenario management see the discussion by Rutherford included in the *Scenario Manager* documentation.

all *vat* rates, called `u_vat`. When `u_vat` is true, then each VAT rate is equalized, and the VAT tax multiplier, τ_{vat} , is allowed to adjust to hold government expenditures constant.

First, we must create a new scenario directory, then copy the policy files into the new directory.

```
c:\model>mkdir uvat
c:\model>copy policy\*. * uvat
```

We don't need to copy the `output` directory over because it will be automatically created when a new scenario is run. In this case, it is easiest to include the global variable into the dynamic and static scenario files. At the top of the file, add a statement such as:

```
if (%u_vat%,
    vat(s) = sum(ss, vat(ss) * a0(ss)) / sum(ss, a0(ss));
    replace("vat") = yes;
);
```

With the new `$setglobal` variable in place, we can now use `solves.bat` to execute a set of new scenarios. Edit the `solves.bat` file, renaming the uniform tariff scenarios to uniform VAT:

```
CALL SOLVE cf_utm horizon=capflow u_tm=yes
CALL SOLVE bp_utm horizon=bopcon u_tm=yes
CALL SOLVE st_utm horizon=static u_tm=yes
CALL SOLVE ss_utm horizon=steady u_tm=yes

CALL SOLVE cf_uvat horizon=capflow u_vat=yes
CALL SOLVE bp_uvat horizon=bopcon u_vat=yes
CALL SOLVE st_uvat horizon=static u_vat=yes
CALL SOLVE ss_uvat horizon=steady u_vat=yes
```

After calling `solves.bat` from the command line, we can generate some tables and plots for these scenarios. First, we generate a table to compare consumption and investment across time-frames.

```
c:\model>table.bat results ss_uvat st_uvat bp_uvat cf_uvat
```

Table 12: Summary Results for Uniform Tariff Scenarios

	ss_uvrat	st_uvrat	bp_uvrat	cf_uvrat
PCTEV	0.3	0.1	0.3	0.3
WAGE_F	0.2	0.0	0.1	0.1
WAGE_I	0.2	-0.1	0.2	0.1
RENT	0.8	1.1	0.8	1.0
REXCH	-0.1	-0.3	0.0	-0.2
LSUP_F	0.9	0.7	0.5	0.5
LSUP_I	-1.3	-1.2	-0.6	-0.8

As expected, we see that the benefits of a uniform VAT are bounded below by the static model results and above by the steady-state model results. We can also plot the transition path between the short-run impact and the new steady-state using the figure routine:

```
c:\model>figure.bat consumption bp_uvrat cf_uvrat
```

Of course, it is impossible to plot items from the static and steady-state scenario runs because they are comparative-static outputs. The transition path for `u_vat` under the free-capital markets and balance-of-payments constraint assumptions is shown in Figure 6. Finally, we compare the welfare gains over time for a uniform tariff and uniform VAT:

```
c:\model>figure.bat consum cf_utm cf_uvrat
```

We find that the welfare benefits of tariff uniformity are greater than those for a uniform VAT. Of course, these figures do not include institutional costs such as the cost of collection and the propensity for tax evasion.

A.4 The Scenario Manager

Day-to-day model analysis is most efficiently done using batch files and a text-editor. But the main point of economic modeling is to identify good and bad policies, then explain the impact to decision-makers and the general public. When presenting to the general public, it is probably best to simply produce a written document which

Figure 6: Welfare Change for Uniform VAT Tax Reform

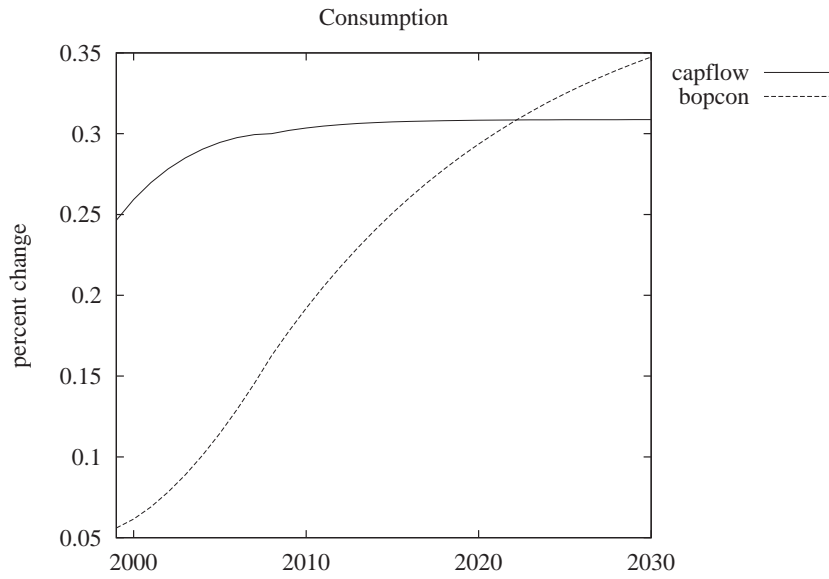
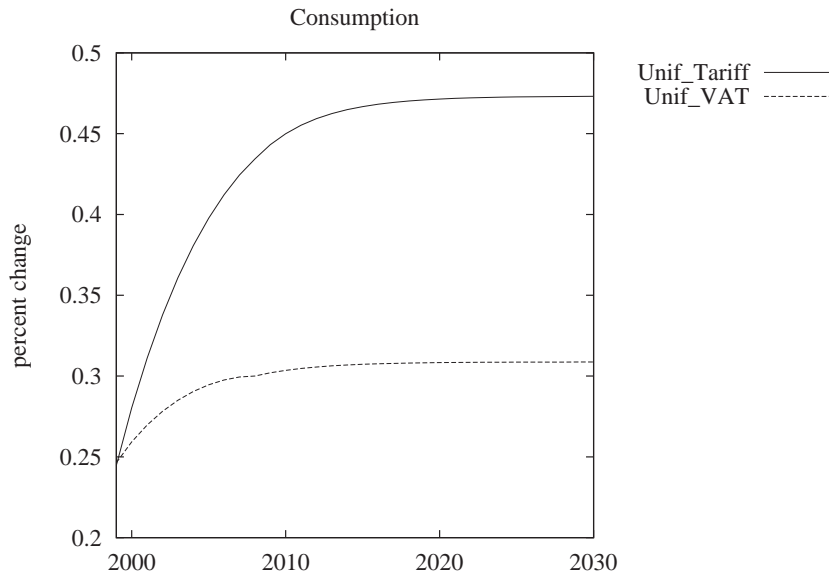

Figure 7: Comparison of Uniform VAT vs. Uniform Tariffs



contains only one or two relevant policy experiments. Decision-makers are different. They will often ask for *several* policy alternatives to help them frame a given policy debate and come to a reasonable decision. For these people, we recommend using the *Scenario Manager* (SM). This tool is a stand-alone program which can run on any Windows-based personal computer. The main advantage of the Scenario Manager is that the existing scenarios can be included into the SM with relatively little effort. Documentation and theology regarding this tool is available on the GAMS homepage in the MPSGE section.

A.5 File Listing

The next two tables offer a listing of each file included in the distribution for reference.

Table 13: Itemized File Description for DynamicMega

data folder:	
<code>build.bat</code>	Batch file which calls <code>makedata</code> to generate a balanced SAM for 1996 and 1999.
<code>makedata.bat</code>	Batch file which calls <code>sam99</code> or <code>sam96</code> for data balancing.
<code>balance.gms</code>	A program used to balance the 1996 and 1999 Colombian SAMs. This program uses an NLP approach to balance the National Accounts.
<code>sam9X.gms</code>	The <code>.xls</code> files are original datasets from Sergio Prada.
<code>sam9X.dat</code>	The <code>.gms</code> files import the XL data into GAMS and write the <code>.dat</code> files for inclusion into GAMS.
<code>sam9X.xls</code>	
<code>balanced99.dat</code>	Balanced datasets used in the MPSGE models. This data is included in the <code>data.gms</code> program in the model directory.
<code>balanced96.dat</code>	
model folder:	
<code>data.gms</code>	Organizes the Colombian SAM data for inclusion into the MPSGE model. Data is mapped onto sectoral demand and output. Tax revenues and transfers are calculated and parameterized. Basically all of the data handling is completed in this file.
<code>static.gms</code>	Static and Steady-State MPSGE formulation for Colombian economy. Uses <code>data.gms</code> for data-handling and preparation.
<code>dynamic.gms</code>	Multi-sectoral dynamic CGE model for Colombia. Uses the same data handling file as the static model: <code>data.gms</code> .

Table 14: Itemized File Description (cont.)

mcf folder:	
<code>run.bat</code>	Batch file which executes the scenarios which are included into the Dynamic model documentation. This file defines the <code>\$setglobal</code> variables and calls GAMS to execute the models.
<code>mcftable.gms</code>	Generates the MCF results tables used in the dynamic model documentation.
<code>mcf-static.gms</code>	Scenario file which includes the <code>static.gms</code> file from the model directory. It loops over all of the tax instruments, performing the MCF calculation.
<code>mcf-dynamic.gms</code>	Scenario file for the <code>dynamic.gms</code> program which performs the dynamic MCF calculations.
<code>output</code>	The <code>output</code> directory holds all of the listing files and results for the MCF scenarios.
policy folder:	
<code>solves.bat</code>	Batch file for conducting multiple scenarios, Calls on <code>solve.bat</code> .
<code>solve.bat</code>	Batch file for solving a single scenario. This program can be invoked from the command line or from another program.
<code>model.gms</code>	An include file which defines the <code>default</code> values for the <code>\$setglobal</code> variables in the model. This is typically considered the default model.
<code>table.gms</code>	GAMS program which generates tables as discussed in the MCF directory.
<code>figure.gms</code>	GAMS program which generates figures as discussed in the MCF directory.
<code>table.bat</code>	Controls the output parameter to show and the scenarios to consider in the table. Generates <code>table.inc</code> and calls on <code>table.gms</code> .
<code>figure.bat</code>	Used to define the output parameter to plot and the scenarios to consider. Generates <code>figure.inc</code> and calls on <code>figure.gms</code> to create a plot using GNUPlot.
<code>scenario.gms</code>	Main scenario GAMS file. This file includes the dynamic model, then conducts a separate counterfactual experiment as defined in the model.

ARCHIVOS DE ECONOMIA

No	Título	Autores	Fecha
1	La coyuntura económica en Colombia y Venezuela	Andrés Langebaek Patricia Delgado Fernando Mesa Parra	Octubre 1992
2	La tasa de cambio y el comercio colombo-venezolano	Fernando Mesa Parra Andrés Langebaek	Noviembre 1992
3	¿Las mayores exportaciones colombianas de café redujeron el precio externo?	Carlos Esteban Posada Andrés Langebaek	Noviembre 1992
4	El déficit público: una perspectiva macroeconómica	Jorge Enrique Restrepo Juan Pablo Zárate Carlos Esteban Posada	Noviembre 1992
5	El costo de uso del capital en Colombia	Mauricio Olivera	Diciembre 1992
6	Colombia y los flujos de capital privado a América Latina	Andrés Langebaek	Febrero 1993
7	Infraestructura física. “Clubs de convergencia” y crecimiento económico	José Dario Uribe	Febrero 1993
8	El costo de uso del capital: una nueva estimación (Revisión)	Mauricio Olivera	Marzo 1993
9	Dos modelos de transporte de carga por carretera	Carlos Esteban Posada Edgar Trujillo Ciro Alvaro Concha Juan Carlos Elorza	Marzo 1993
10	La determinación del precio interno del café en un modelo de optimización intertemporal	Carlos Felipe Jaramillo Carlos Esteban Posada Edgar Trujillo	Abril 1993
11	El encaje óptimo	Edgar Trujillo Ciro Carlos Esteban Posada	Mayo 1993
12	Crecimiento económico, “Capital humano” y educación: la teoría y el caso colombiano posterior a 1945	Carlos Esteban Posada	Junio 1993
13	Estimación del PIB trimestral según los componentes del gasto	Rafael Cubillos Fanny Mercedes Valderrama	Junio 1993
14	Diferencial de tasas de interés y flujos de capital en Colombia (1980-1993)	Andrés Langebaek	Agosto 1993
15	Empleo y capital en Colombia: nuevas estimaciones (1950-1992)	Adriana Barrios Marta Luz Henao Carlos Esteban Posada Fanny Mercedes Valderrama Diego Mauricio Vásquez	Septiembre 1993

ARCHIVOS DE ECONOMIA

No	Título	Autores	Fecha
16	Productividad, crecimiento y ciclos en la economía colombiana (1967-1992)	Carlos Esteban Posada	Septiembre 1993
17	Crecimiento económico y apertura en Chile y México y perspectivas para Colombia	Fernando Mesa Parra	Septiembre 1993
18	El papel del capital público en la producción, inversión y el crecimiento económico en Colombia	Fabio Sánchez Torres	Octubre 1993
19	Tasa de cambio real y tasa de cambio de equilibrio	Andrés Langebaek	Octubre 1993
20	La evolución económica reciente: dos interpretaciones alternativas	Carlos Esteban Posada	Noviembre 1993
21	El papel de gasto público y su financiación en la coyuntura actual: algunas implicaciones complementarias	Alvaro Zarta Avila	Diciembre 1993
22	Inversión extranjera y crecimiento económico	Alejandro Gaviria Javier Alberto Gutiérrez	Diciembre 1993
23	Inflación y crecimiento en Colombia	Alejandro Gaviria Carlos Esteban Posada	Febrero 1994
24	Exportaciones y crecimiento en Colombia	Fernando Mesa Parra	Febrero 1994
25	Experimento con la vieja y la nueva teoría del crecimiento económico (¿porqué crece tan rápido China?)	Carlos Esteban Posada	Febrero 1994
26	Modelos económicos de criminalidad y la posibilidad de una dinámica prolongada	Carlos Esteban Posada	Abril 1994
27	Regímenes cambiarios, política macroeconómica y flujos de capital en Colombia	Carlos Esteban Posada	Abril 1994
28	Comercio intraindustrial: el caso colombiano	Carlos Pombo	Abril 1994
29	Efectos de una bonanza petrolera a la luz de un modelo de optimización intertemporal	Hernando Zuleta Juan Pablo Arango	Mayo 1994
30	Crecimiento económico y productividad en Colombia: una perspectiva de largo plazo (1957-1994)	Sergio Clavijo	Junio 1994
31	Inflación o desempleo: ¿Acaso hay escogencia en Colombia?	Sergio Clavijo	Agosto 1994

ARCHIVOS DE ECONOMIA

No	Título	Autores	Fecha
32	La distribución del ingreso y el sistema financiero	Edgar Trujillo Ciro	Agosto 1994
33	La trinidad económica imposible en Colombia: estabilidad cambiaria, independencia monetaria y flujos de capital libres	Sergio Clavijo	Agosto 1994
34	¿'Déjà vu?: tasa de cambio, deuda externa y esfuerzo exportador en Colombia.	Sergio Clavijo	Mayo 1995
35	La crítica de Lucas y la inversión en Colombia: nueva evidencia	Mauricio Cárdenas Mauricio Olivera	Septiembre 1995
36	Tasa de Cambio y ajuste del sector externo en Colombia	Fernando Mesa Parra Dairo Estrada	Septiembre 1995
37	Análisis de la evolución y composición del Sector Público	Mauricio Olivera G. Manuel Fernando Castro Q. Fabio Sánchez T.	Septiembre 1995
38	Incidencia distributiva del IVA en un modelo del ciclo de vida	Juan Carlos Parra Osorio Fabio José Sánchez T.	Octubre 1995
39	Por qué los niños pobres no van a la escuela? (Determinantes de la asistencia escolar en Colombia)	Fabio Sánchez Torres Jairo Augusto Núñez M.	Noviembre 1995
40	Matriz de Contabilidad Social 1992	Fanny M. Valderrama Javier Alberto Gutiérrez	Diciembre 1995
41	Multiplicadores de Contabilidad Derivados de la Matriz de Contabilidad Social	Javier Alberto Gutiérrez Fanny M. Valderrama G.	Enero 1996
42	El ciclo de referencia de la economía colombiana	Martin Maurer María Camila Uribe S.	Febrero 1996
43	Impacto de las transferencias intergubernamentales en la distribución interpersonal del ingreso en Colombia	Juan Carlos Parra Osorio	Marzo 1996
44	Auge y colapso del ahorro empresarial en Colombia 1983-1994	Fabio Sánchez Torres Guillermo Murcia Guzmán Carlos Oliva Neira	Abril 1996
45	Evolución y comportamiento del gasto público en Colombia 1950-1994	Cielo María Numpaque Ligia Rodríguez Cuestas	Mayo 1996
46	Los efectos no considerados de la apertura económica en el mercado laboral industrial	Fernando Mesa Parra Javier Alberto Gutiérrez	Mayo 1996
47	Un modelo de Financiamiento óptimo de un aumento permanente en el gasto público: Una ilustración con el caso colombiano.	Alvaro Zarta Avila	Junio 1996

ARCHIVOS DE ECONOMIA

No	Título	Autores	Fecha
48	Estadísticas descriptivas del mercado laboral masculino y femenino en Colombia: 1976 -1995	Rocío Ribero M. Carmen Juliana García B.	Agosto 1996
49	Un sistema de indicadores líderes para Colombia	Martín Maurer María Camila Uribe Javier Birchenall	Agosto 1996
50	Evolución y determinantes de la productividad en Colombia: Un análisis global y sectorial	Fabio Sánchez Torres Jorge Iván Rodríguez Jairo Núñez Méndez	Agosto 1996
51	Gobernabilidad y Finanzas Públicas en Colombia	César A. Caballero R	Noviembre 1996
52	Tasas Marginales Efectivas de Tributación en Colombia	Mauricio Olivera G.	Noviembre 1996
53	Un modelo keynesiano para la economía colombiana	Fabio José Sánchez T. Clara Elena Parra	Febrero 1997
54	Trimestralización del Producto Interno Bruto por el lado de la oferta.	Fanny M. Valderrama	Febrero 1997
55	Poder de mercado, economías de escala, complementariedades intersectoriales y crecimiento de la productividad en la industria colombiana.	Juán Mauricio Ramírez	Marzo 1997
56	Estimación y calibración de sistemas flexibles de gasto.	Orlando Gracia Gustavo Hernández	Abril 1997
57	Mecanismos de ahorro e Inversión en las Empresas Públicas Colombianas: 1985-1994	Fabio Sánchez Torres Guillermo Murcia G.	Mayo 1997
58	Capital Flows, Savings and investment in Colombia 1990-1996	José Antonio Ocampo G. Camilo Ernesto Tovar M.	Mayo 1997
59	Un Modelo de Equilibrio General Computable con Competencia imperfecta para Colombia	Juan Pablo Arango Orlando Gracia Gustavo Hernández Juan Mauricio Ramírez	Junio 1997
60	El cálculo del PIB Potencial en Colombia	Javier A. Birchenall J.	Julio 1997
61	Determinantes del Ahorro de los hogares. Explicación de su caída en los noventa.	Alberto Castañeda C. Gabriel Piraquive G.	Julio 1997
62	Los ingresos laborales de hombres y mujeres en Colombia: 1976-1995	Rocío Ribero Claudia Meza	Agosto 1997

ARCHIVOS DE ECONOMIA

No	Título	Autores	Fecha
63	Determinantes de la participación laboral de hombres y mujeres en Colombia: 1976-1995	Rocío Ribero Claudia Meza	Agosto 1997
64	Inversión bajo incertidumbre en la Industria Colombiana: 1985-1995	Javier A. Birchenall	Agosto 1997
65	Modelo IS-LM para Colombia. Relaciones de largo plazo y fluctuaciones económicas.	Jorge Enrique Restrepo	Agosto 1997
66	Correcciones a los Ingresos de las Encuestas de hogares y distribución del Ingreso Urbano en Colombia.	Jairo A. Núñez Méndez Jaime A. Jiménez Castro	Septiembre 1997
67	Ahorro, Inversión y Transferencias en las Entidades Territoriales Colombianas	Fabio Sánchez Torres Mauricio Olivera G. Giovanni Cortés S.	Octubre 1997
68	Efectos de la Tasa de cambio real sobre la Inversión industrial en un Modelo de transferencia de precios	Fernando Mesa Parra Leyla Marcela Salguero Fabio Sánchez Torres	Octubre 1997
69	Convergencia Regional: Una revisión del caso Colombiano.	Javier A. Birchenall Guillermo E. Murcia G.	Octubre 1997
70	Income distribution, human capital and economic growth in Colombia.	Javier A. Birchenall	Octubre 1997
71	Evolución y determinantes del Ahorro del Gobierno Central.	Fabio Sánchez Torres Ma. Victoria Angulo	Noviembre 1997
72	Macroeconomic Performance and Inequality in Colombia: 1976-1996	Raquel Bernal Mauricio Cárdenas Jairo Núñez Méndez Fabio Sánchez Torres	Diciembre 1997
73	Liberación comercial y salarios en Colombia: 1976-1994	Donald Robbins	Enero 1998
74	Educación y salarios relativos en Colombia: 1976-1995 Determinantes, evolución e implicaciones para la distribución del Ingreso	Jairo Núñez Méndez Fabio Sánchez Torres	Enero 1998
75	La tasa de interés "óptima"	Carlos Esteban Posada Edgar Trujillo Ciro	Febrero 1998
76	Los costos económicos de la criminalidad y la violencia en Colombia: 1991-1996	Edgar Trujillo Ciro Martha Elena Badel	Marzo 1998
77	Elasticidades Precio y Sustitución para la Industria Colombiana	Juán Pablo Arango Orlando Gracia Gustavo Hernández	Marzo 1998

ARCHIVOS DE ECONOMIA

No	Título	Autores	Fecha
78	Flujos Internacionales de Capital en Colombia: Un enfoque de Portafolio	Ricardo Rocha García Fernando Mesa Parra	Marzo 1998
79	Macroeconomía, ajuste estructural y equidad en Colombia: 1978-1996	José Antonio Ocampo María José Pérez Camilo Ernesto Tovar Francisco Javier Lasso	Marzo 1998
80	La Curva de Salarios para Colombia. Una Estimación de las Relaciones entre el Desempleo, la Inflación y los Ingresos Laborales, 1984- 1996.	Fabio Sánchez Torres Jairo Núñez Méndez	Marzo 1998
81	Participación, Desempleo y Mercados Laborales en Colombia	Jaime Tenjo G. Rocio Ribero M.	Abril 1998
82	Reformas comerciales, márgenes de beneficio y productividad en la industria colombiana	Juán Pablo Arango Orlando Gracia Gustavo Hernández Juán Mauricio Ramírez	Abril 1998
83	Capital y Crecimiento Económico en un Modelo Dinámico: Una presentación de la dinámica Transicional para los casos de EEUU y Colombia	Alvaro Zarta Avila	Mayo 1998.
84	Determinantes de la Inversión en Colombia: Evidencia sobre el capital humano y la violencia.	Clara Helena Parra	Junio 1998.
85	Mujeres en sus casas: Un recuento de la población Femenina económicamente activa	Piedad Urdinola Contreras	Junio 1998.
86	Descomposición de la desigualdad del Ingreso laboral Urbano en Colombia: 1976-1997	Fabio Sánchez Torres Jairo Núñez Méndez	Junio 1998.
87	El tamaño del Estado Colombiano Indicadores y tendencias 1976-1997	Angela Cordi Galat	Junio 1998.
88	Elasticidades de sustitución de las importaciones Para la economía colombiana.	Gustavo Hernández	Junio 1998.
89	La tasa natural de desempleo en Colombia	Martha Luz Henao Norberto Rojas	Junio 1998.
90	The role of shocks in the colombian economy	Ana María Menéndez	Julio 1998.
91	The determinants of Human Capital Accumulation in Colombia, with implications for Trade and Growth Theory	Donald J. Robbins	Julio 1998.
92	Estimaciones de funciones de demanda de trabajo dinámicas para la economía colombiana, 1980-1996	Alejandro Vivas Benítez Stefano Farné Dagoberto Urbano	Julio 1998.
93	Análisis de las relaciones entre violencia y equidad	Alfredo Sarmiento Lida Marina Becerra	Agosto 1998.

ARCHIVOS DE ECONOMIA

No	Título	Autores	Fecha
94	Evaluación teórica y empírica de las exportaciones no tradicionales en Colombia	Fernando Mesa Parra María Isabel Cock Angela Patricia Jiménez	Agosto 1998.
95	Valoración económica del empleo doméstico femenino no remunerado, en Colombia, 1978-1993	Piedad Urdinola Contreras	Agosto 1998.
96	Eficiencia en el Gasto Público de Educación.	María Camila Uribe	Agosto 1998.
97	El desempleo en Colombia: tasa natural, desempleo cíclico y estructural y la duración del desempleo. 1976-1998.	Jairo Núñez M. Raquel Bernal S.	Septiembre 1998.
98	Productividad y retornos sociales del Capital humano: Microfundamentos y evidencia para Colombia.	Francisco A. González R. Carolina Guzmán R. Angela L. Pachón G.	Noviembre 1998.
99	Reglas monetarias en Colombia y Chile	Jorge E. Restrepo L.	Enero 1999.
100	Inflation Target Zone: The Case of Colombia 1973-1994	Jorge E. Restrepo L.	Febrero 1999.
101	¿ Es creíble la Política Cambiaria en Colombia?	Carolina Hoyos V.	Marzo 1999.
102	La Curva de Phillips, la Crítica de Lucas y la persistencia de la inflación en Colombia	Javier A. Birchenall	Abril 1999.
103	Un modelo macroeconómico para la economía Colombiana	Javier A. Birchenall Juan Daniel Oviedo	Abril 1999.
104	Una revisión de la literatura teórica y la experiencia Internacional en regulación	Marcela Eslava Mejía	Abril 1999.
105	El transporte terrestre de carga en Colombia Documento para el Taller de Regulación.	Marcela Eslava Mejía Eleonora Lozano Rodríguez	Abril 1999.
106	Notas de Economía Monetaria. (Primera Parte)	Juan Carlos Echeverry G.	Abril 1999.
107	Ejercicios de Causalidad y Exogeneidad para Ingresos salariales nominales públicos y privados Colombianos (1976-1997).	Mauricio Bussolo Orlando Gracia Camilo Zea	Mayo 1999.
108	Real Exchange Rate Swings and Export Behavior: Explaining the Robustness of Chilean Exports.	Felipe Illanes	Mayo 1999.
109	Segregación laboral en las 7 principales ciudades del país.	Piedad Urdinola	Mayo 1999.
110	Estimaciones trimestrales de la línea de pobreza y sus relaciones con el desempeño macroeconómico Colombiano. (1977-1997)	Jairo Núñez Méndez Fabio José Sánchez T.	Mayo 1999
111	Costos de la corrupción en Colombia.	Marta Elena Badel	Mayo 1999

ARCHIVOS DE ECONOMIA

No	Título	Autores	Fecha
112	Relevancia de la dinámica transicional para el crecimiento de largo plazo: Efectos sobre las tasas de interés real, la productividad marginal y la estructura de la producción para los casos de EEUU y Colombia..	Alvaro Zarta	Junio 1999
113	La recesión actual en Colombia: Flujos, Balances y Política anticíclica	Juan Carlos Echeverry	Junio 1999
114	Monetary Rules in a Small Open Economy	Jorge E. Restrepo L.	Junio 1999
115	El Balance del Sector Público y la Sostenibilidad Fiscal en Colombia	Juan Carlos Echeverry Gabriel Piraquive Natalia Salazar Ma. Victoria Angulo Gustavo Hernández Cielo Ma. Numpaqué Israel Fainboim Carlos Jorge Rodriguez	Junio 1999
116	Crisis y recuperación de las Finanzas Públicas. Lecciones de América Latina para el caso colombiano.	Marcela Eslava Mejía	Julio 1999
117	Complementariedades Factoriales y Cambio Técnico en la Industria Colombiana.	Gustavo Hernández Juan Mauricio Ramírez	Julio 1999
118	¿Hay un estancamiento en la oferta de crédito?	Juan Carlos Echeverry Natalia Salazar	Julio 1999
119	Income distribution and macroeconomics in Colombia.	Javier A. Birchenall J.	Julio 1999.
120	Transporte carretero de carga. Taller de regulación. DNP-UMACRO. Informe final.	Juan Carlos Echeverry G. Marcela Eslava Mejía Eleonora Lozano Rodriguez	Agosto 1999.
121	¿ Se cumplen las verdades nacionales a nivel regional? Primera aproximación a la construcción de matrices de contabilidad social regionales en Colombia.	Nelly. Angela Cordi Galat	Agosto 1999.
122	El capital social en Colombia. La medición nacional con el BARCAS Separata N° 1 de 5	John SUDARSKY	Octubre 1999.
123	El capital social en Colombia. La medición nacional con el BARCAS Separata N° 2 de 5	John SUDARSKY	Octubre 1999.
124	El capital social en Colombia. La medición nacional con el BARCAS Separata N° 3 de 5	John SUDARSKY	Octubre 1999.
125	El capital social en Colombia. La medición nacional con el BARCAS Separata N° 4 de 5	John SUDARSKY	Octubre 1999.

ARCHIVOS DE ECONOMIA

No	Título	Autores	Fecha
126	El capital social en Colombia. La medición nacional con el BARCAS Separata N° 5 de 5	John SUDARSKY	Octubre 1999.
127	The Liquidity Effect in Colombia	Jorge E. Restrepo	Noviembre 1999.
128	Upac: Evolución y crisis de un modelo de desarrollo.	Juan C Echeverry Orlando Gracia B. Piedad Urdinola	Diciembre 1999.
129	Confronting fiscal imbalances via intertemporal Economics, politics and justice: the case of Colombia	Juan C Echeverry Verónica Navas-Ospina	Diciembre 1999.
130	La tasa de interés en la coyuntura reciente en Colombia.	Jorge Enrique Restrepo Edgar Trujillo Ciro	Diciembre 1999.
131	Los ciclos económicos en Colombia. Evidencia Empírica (1977-1998)	Jorge Enrique Restrepo José Daniel Reyes Peña	Enero 2000.
132	Colombia's natural trade partners and its bilateral Trade performance: Evidence from 1960 to 1996	Hernán Eduardo Vallejo	Enero 2000.
133	Los derechos constitucionales de prestación y sus Implicaciones económico- políticas. Los casos del derecho a la salud y de los derechos de los reclusos	Luis Carlos Sotelo	Febrero 2000.
134	La reactivación productiva del sector privado colombiano (Documento elaborado para el BID)	Luis Alberto Zuleta	Marzo 2000.
135	Geography and Economic Development: A Municipal Approach for Colombia.	Fabio José Sánchez T. Jairo Núñez Méndez	Marzo 2000.
136	La evaluación de resultados en la modernización del Estado en América Latina. Restricciones y Estrategia para su desarrollo.	Eduardo Wiesner Durán	Abril 2000.
137	La regulación de precios del transporte de carga por Carretera en Colombia.	Marcela Eslava Mejía	Abril 2000.
138	El conflicto armado en Colombia. Una aproximación a la teoría de juegos.	Yuri Gorbaneff Flavio Jácome	Julio 2000.
139	Determinación del consumo básico de agua potable subsidiario en Colombia.	Juan Carlos Junca Salas	Noviembre 2000.
140	Incidencia fiscal de los incentivos tributarios	Juan Ricardo Ortega Gabriel Armando Piraquive Gustavo Adolfo Hernández Carolina Soto Losada Sergio Iván Prada Juan Mauricio Ramirez	Noviembre 2000.

ARCHIVOS DE ECONOMIA

No	Título	Autores	Fecha
141	Exenciones tributarias: Costo fiscal y análisis de incidencia	Gustavo A. Hernández Carolina Soto Losada Sergio Iván Prada Juan Mauricio Ramirez	Diciembre 2000
142	La contabilidad del crecimiento, las dinámicas transicionales y el largo plazo: Una comparación internacional de 46 países y una presentación de casos de economías tipo: EEUU, Corea del Sur y Colombia.	Alvaro Zarta Avila	Febrero 2001
143	¿Nos parecemos al resto del mundo? El Conflicto colombiano en el contexto internacional.	Juan Carlos Echeverry G. Natalia Salazar Ferro Verónica Navas Ospina	Febrero 2001
144	Inconstitucionalidad del Plan Nacional de Desarrollo: causas, efectos y alternativas.	Luis Edmundo Suárez S. Diego Mauricio Avila A.	Marzo 2001
145	La afiliación a la salud y los efectos redistributivos de los subsidios a la demanda.	Hernando Moreno G.	Abril 2001
146	La participación laboral: ¿qué ha pasado y qué podemos esperar?	Mauricio Santamaría S. Norberto Rojas Delgadillo	Abril 2001
147	Análisis de las importaciones agropecuarias en la década de los Noventa.	Gustavo Hernández Juan Ricardo Perilla	Mayo 2001
148	Impacto económico del programa de Desarrollo alternativo del Plan Colombia	Gustavo A. Hernández Sergio Iván Prada Juan Mauricio Ramírez	Mayo 2001
149	Análisis de la presupuestación de la inversión de la Nación.	Ulpiano Ayala Oramas	Mayo 2001
150	DNPENSION: Un modelo de simulación para estimar el costo fiscal del sistema pensional colombiano.	Juan Carlos Parra Osorio	Mayo 2001
151	La oferta de combustible de Venezuela en la frontera con Colombia: una aproximación a su cuantificación	Hernando Moreno G.	Junio 2001
152	Shocks fiscales y términos de intercambio en el caso colombiano.	Ómer ÖZAK MUÑOZ.	Julio 2001
153	Demanda por importaciones en Colombia: Una estimación.	Igor Esteban Zuccardi	Julio 2001
154	Elementos para mejorar la adaptabilidad del mercado laboral colombiano.	Mauricio Santa María S. Norberto Rojas Delgadillo	Agosto 2001
155	¿Qué tan poderosas son las aerolíneas colombianas? Estimación de poder de mercado de las rutas colombianas.	Ximena Peña Parga	Agosto 2001

ARCHIVOS DE ECONOMIA

No	Título	Autores	Fecha
156	Elementos para el debate sobre una nueva reforma pensional en Colombia.	Juan Carlos Echeverry Andrés Escobar Arango César Merchán Hernández Gabriel Piraquive Galeano Mauricio Santa María S.	Septiembre 2001
157	Agregando votos en un sistema altamente desistitucionalizado.	Francisco Gutiérrez Sanín	Octubre 2001
158	Eficiencia -X en el Sector Bancario Colombiano	Carlos Alberto Castro I	Noviembre 2001
159	Determinantes de la calidad de la educación en Colombia.	Alejandro Gaviria Jorge Hugo Barrientos	Noviembre 2001
160	Evaluación de la descentralización municipal. Descentralización y macroeconomía	Fabio Sánchez Torres	Noviembre 2001
161	Impuestos a las transacciones: Implicaciones sobre el bienestar y el crecimiento.	Rodrigo Suescún	Noviembre 2001
162	Strategic Trade Policy and Exchange Rate Uncertainty	Fernando Mesa Parra	Noviembre 2001
163	Evaluación de la descentralización municipal en Colombia. Avances y resultados de la descentralización Política en Colombia	Alberto Maldonado C.	Noviembre 2001
164	Choques financieros, precios de activos y recesión en Colombia.	Alejandro Badel Flórez	Noviembre 2001
165	Evaluación de la descentralización municipal en Colombia. ¿Se consolidó la sostenibilidad fiscal de los municipios colombianos durante los años noventa.	Juan Gonzalo Zapata Olga Lucía Acosta Adriana González	Noviembre 2001
166	Evaluación de la descentralización municipal en Colombia. La descentralización en el Sector de Agua potable y Saneamiento básico.	Maria Mercedes Maldonado Gonzalo Vargas Forero	Noviembre 2001
167	Evaluación de la descentralización municipal en Colombia. La relación entre corrupción y proceso de descentralización en Colombia.	Edgar González Salas	Diciembre 2001
168	Evaluación de la descentralización municipal en Colombia. Estudio general sobre antecedentes, diseño, avances y resultados generales del proceso de descentralización territorial en el Sector Educativo.	Carmen Helena Vergara Mary Simpson	Diciembre 2001
169	Evaluación de la descentralización municipal en Colombia. Componente de capacidad institucional.	Edgar González Salas	Diciembre 2001
170	Evaluación de la descentralización municipal en Colombia. Evaluación de la descentralización en Salud en Colombia.	Iván Jaramillo Pérez	Diciembre 2001
171	External Trade, Skill, Technology and the recent increase of income inequality in Colombia	Mauricio Santa María S.	Diciembre 2001

ARCHIVOS DE ECONOMIA

No	Título	Autores	Fecha
172	Seguimiento y evaluación de la participación de los resguardos indígenas en los ingresos corrientes de la Nación para el período 1998 y 1999.	Dirección de Desarrollo Territorial	Diciembre 2001
173	Exposición de Motivos de la Reforma de la Ley 60 de 1993. Sector Educación y Sector Salud	Dirección de Desarrollo Social	Diciembre 2001
174	Transferencias, incentivos y la endogenidad del gasto Territorial. Seminario internacional sobre Federalismo fiscal - Secretaría de Hacienda de México, CEPAL, ILPES, CAF - Cancún, México. 18-20 de Mayo de 2000	Eduardo Wiesner Durán	Enero 2002.
175	Cualificación laboral y grado de sindicalización	Flavio Jácome Liévano	Enero 2002.
176	OFFSETS: Aproximación teórica y experiencia Internacional.	Nohora Eugenia Posada Yaneth Cristina Giha Tovar Paola Buendía García Alvaro José Chávez G.	Febrero 2002.
177	Pensiones: conceptos y esquemas de financiación	César Augusto Merchán H.	Febrero 2002.
178	La erradicación de las minas antipersonal sembradas en Colombia - Implicaciones y costos-	Yilberto Lahuerta P. Ivette María Altamar	Marzo 2002.
179	Economic growth in Colombia: A reversal of "Fortune"?	Mauricio Cárdenas S.	Marzo 2002.
180	El siglo del modelo de desarrollo.	Juan Carlos Echeverry G	Abril 2002.
181	Metodología de un Modelo ARIMA condicionado para el pronóstico del PIB.	Juan Pablo Herrera S. Gustavo A. Hernández D.	Abril 2002.
182	¿Cuáles son los colombianos con pensiones privilegiadas?	César Augusto Merchán H.	Abril 2002.
183	Garantías en carreteras de primera generación. Impacto económico.	José Daniel Reyes Peña.	Abril 2002
184	Impacto económico de las garantías de la Nación en proyectos de infraestructura.	José Daniel Reyes Peña.	Abril 2002
185	Aproximación metodológica y cuantitativa de los costos económicos generados por el problema de las drogas ilícitas en Colombia (1995 - 2000)	Ricardo Pérez Sandoval Andrés Vergara Ballén Yilberto Lahuerta P	Abril 2002
186	Tendencia, ciclos y distribución del ingreso en Colombia: una crítica al concepto de "modelo de desarrollo"	Juan Carlos Echeverry G. Andrés Escobar Arango Mauricio Santa María S.	Abril 2002.
187	Crecimiento y ciclos económicos. Efectos de los choques de oferta y demanda en el crecimiento colombiano.	Igor Esteban Zuccardi H.	Mayo 2002.

ARCHIVOS DE ECONOMIA

No	Título	Autores	Fecha
188	A general equilibrium model for tax policy analysis in Colombia. The MEGATAX model.	Thomas F. Rutherford. Miles K. Light	Mayo 2002.
189	A dynamic general equilibrium model for tax policy analysis in Colombia.	Thomas F. Rutherford. Miles K. Light Gustavo A. Hernández	Mayo 2002.