

# MPRA

Munich Personal RePEc Archive

## **Robustness and Stability of Limit Cycles in a Class of Planar Dynamical Systems**

Datta, Soumya

Faculty of Economics, South Asian University

June 2014

Online at <https://mpra.ub.uni-muenchen.de/56970/>

MPRA Paper No. 56970, posted 29 Jun 2014 05:42 UTC

# Robustness and Stability of Limit Cycles in a Class of Planar Dynamical Systems

SOUMYA DATTA\*

*Faculty of Economics, South Asian University, New Delhi, INDIA.  
Email:soumya@econ.sau.ac.in*

October 20, 2013

## Abstract

Using a macroeconomic example, the paper proposes an algorithm to symbolically construct the topological normal form of Andronov-Hopf bifurcation. It also offers a program, using the Computer Algebra System ‘Maxima’, to apply this algorithm. In case the limit cycle turns out to be unstable, the possibilities of the dynamics converging to another limit cycle is explored.

*Keywords:* Andronov-Hopf bifurcation, Limit cycles

*JEL classification:* C62; C69

---

\*Parts of this paper are drawn from the author’s Ph.D. thesis, titled *Macrodynamics of Financing Investment: Applications of Lotka-Volterra Class of Models*, completed at CESP, JNU, New Delhi under the supervision of Prof. Anjan Mukherji in 2011.

# 1 Introduction

The Andronov-Hopf bifurcation theorem is widely used to establish existence of limit cycles in economic systems.<sup>1</sup> However, in addition to the existence conditions, the Andronov-Hopf bifurcation must satisfy the non-degeneracy condition in order to prevent the degeneration of these limit cycles.<sup>2</sup> Further, the Andronov-Hopf bifurcation might either be supercritical or subcritical. As pointed out by (Benhabib & Miyao 1981, Kind 1999), these two possibilities might have different economic interpretations. The supercritical case corresponds to stable limit cycles surrounding an unstable fixed point, and hence might be interpreted as stylized business or growth cycles. The subcritical case, on the other hand, correspond to repelling closed orbit surrounding a fixed point which is still stable, and might be interpreted to be corresponding to the concept of corridor stability as developed by (Leijonhufvud 1973). A meaningful economic analysis of these limit cycles, therefore, requires a test for both non-degeneracy and stability.

We should point out here that numerically testing an Andronov-Hopf bifurcation point for non-degeneracy and stability is quite widespread in the literature in natural sciences. In fact, software packages like XPPAUT or MATCONT already incorporate some of the standard algorithms for these tests. A substantial literature in economics, however, relies on symbolic computation. This is one of the reasons why the literature in economics often stops short of testing Andronov-Hopf bifurcation for non-degeneracy and stability. This is one of the concerns we attempt to address in this paper. With this objective, we use a method outlined by (Kuznetsov 1997) and (Edneral 2007) to *symbolically* compute the topological normal form for an Andronov-Hopf bifurcation in plane and test for non-degeneracy and stability of its limit cycles. A related issue which we also address in this paper is to explore whether, under certain conditions, there is a possibility of alternate stable limit cycles emerging when the test for stability of the limit cycle from Andronov-Hopf bifurcation fails.

We use a macroeconomic model developed in Datta (2012) to illustrate our method. We contend that the choice of our model is without any loss of generality. The method developed here can easily be applied in similar economic models represented by a large class of planar dynamical systems.

---

<sup>1</sup>See, for instance, (Asada & Yoshida 2003), (Asada, Chen, Chiarella & Flaschel 2006), (Barnett & He 1998), (Barnett & He 2006), (Benhabib & Nishimura 1979), (Benhabib & Miyao 1981), (Chiarella & Flaschel 2000), (Chiarella, Flaschel & Franke 2005), (Franke 1992), (Velupillai 2006) and (Minagawa 2007).

<sup>2</sup>See, for instance, (Kuznetsov 1997).

## 2 The Model

In the following sections, we use the planar dynamical system given below, representing the macroeconomic model developed in (Datta 2012):

$$\begin{aligned}\dot{g}(t) &= [a_1g(t) - a_2\{g(t)\}^2 - a_3d(t) + a_4]hg(t) \\ \dot{d}(t) &= [b_1g(t) - b_2d(t) + b_3]d(t)\end{aligned}\tag{1}$$

where  $g \in [0, g_{\max}]$  is the rate of investment (or the ratio of investment to capital stock),  $g_{\max}$  is the maximum possible rate of investment<sup>3</sup>  $d$  is the debt-capital ratio and  $a_1, a_2, a_3, a_4, b_1, b_2, b_3 \in ]0, \infty[$  are composite parameters consisting of various combination of various behavioral parameters.  $h$  is a control parameter. In the model in Datta (2012),  $h$  represented the speed of adjustment of actual to the desired rate of investment; more generally, this might be interpreted as a parameter representing the speed of adjustment of the variable  $g$ .<sup>4</sup>

We note that the dynamical system represented by (1) has six steady states, which we refer to as  $E_i(\bar{g}_i, \bar{d}_i)$ ,  $i \in [0, 1]$ . A full list of these steady states is provided in appendix A. We further note that at most two of these steady states,  $E_5(\bar{g}_5, \bar{d}_5)$  and  $E_6(\bar{g}_6, \bar{d}_6)$ , are economically meaningful, i.e. lies within real positive orthant. We further note the following:

**Lemma 1.** *For the dynamical system represented by (1), the real positive orthant is invariant.*

*Proof.* Provided in appendix B. □

It follows from lemma 1 that since only dynamics strictly within the real positive orthant is economically meaningful, we focus our attention on only such trajectories and ignore other trajectories in the rest of our discussion. In other words, we only consider  $E_5$  and  $E_6$  for discussion, and do not discuss the other steady states in the rest of this study.

Next we turn our attention to the trajectories starting from an initial point inside the real positive orthant. Depending on the configuration of parameters, we can list four different possibilities exhibiting qualitatively different dynamics. These four cases are illustrated in figure 1. Details of parametric conditions giving rise to these four cases are discussed in appendix C.

---

<sup>3</sup>In other words,  $g_{\max}$  represents resource constraint commonplace in economic models.

<sup>4</sup>We refer interested readers to Datta (2012) for details and derivation of this model. These details, however, are not relevant for the purpose of illustration of our method in this paper.

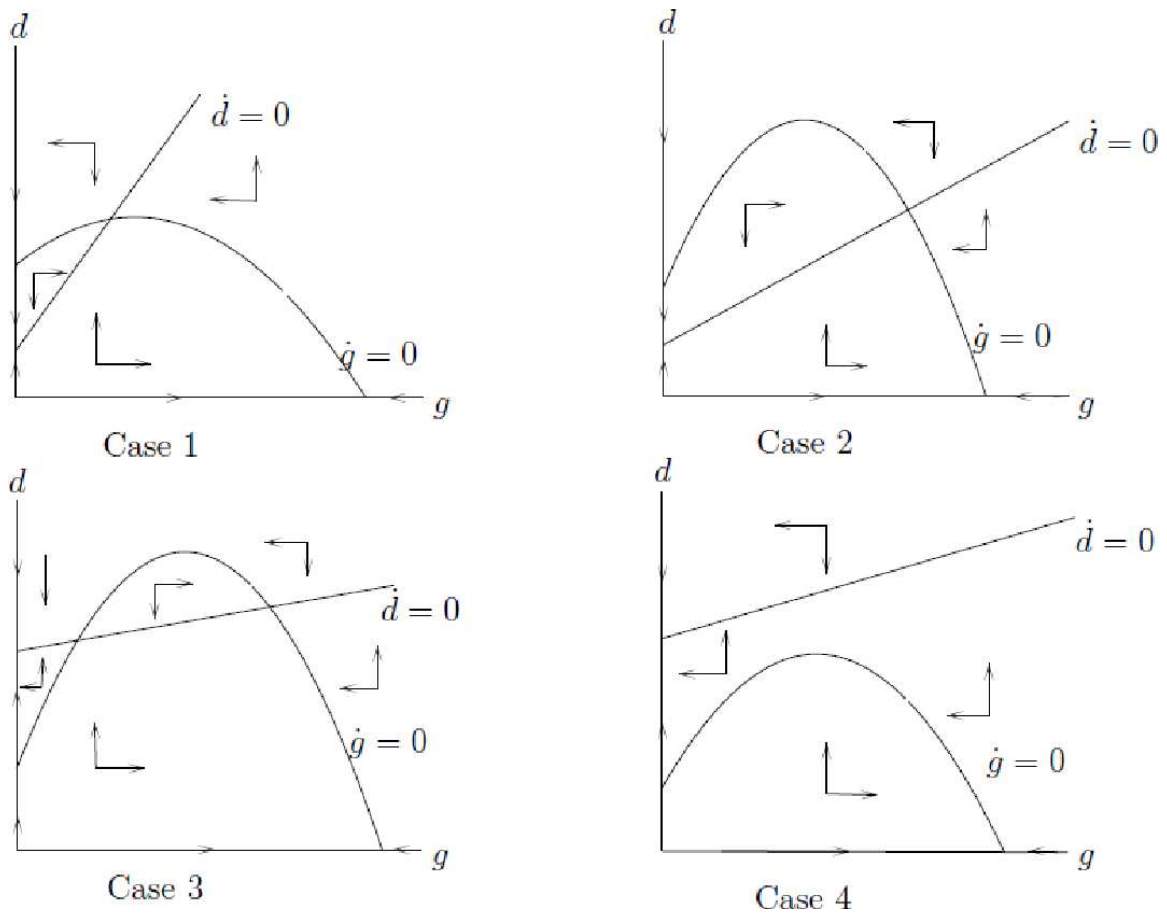

Figure 1: Phase diagram of (1): Four cases

Further, performing the Routh-Hurwitz condition for local stability on the two economically meaningful steady states,  $E_5$  and  $E_6$ , we note that (a) *whenever the non-trivial steady state solution,  $E_5$  exists and is distinct from  $E_6$  and lies in the interior of real positive orthant, it is a saddle-point*; and, (b) *depending on the configuration of the parameters, the non-trivial steady state solution,  $E_6$ , whenever it exists and is distinct from  $E_5$  and lies within the interior of the real positive orthant, is either a source or a sink*.

### 3 Andronov-Hopf Bifurcation

**Lemma 2.** *For an appropriate value of the speed of adjustment,  $h$ , of the actual rate of investment to its desired rate, the characteristic equation to (1) evaluated at the non-trivial steady state,  $E_6$ , has purely imaginary roots.*

*Proof.* Consider the trace of the jacobian of the right hand side of (1), evaluated at

$E_6$ , and recall that for case 1 of figure 1,  $\bar{g}_6 > 0$ ,  $\bar{d}_6 > 0$  and  $a_1 - 2a_2\bar{g}_6 > 0$ , so that

$$\frac{\partial(\text{Trace})}{\partial h} = (a_1 - 2a_2\bar{g}_6)\bar{g}_6 > 0 \quad (2)$$

i.e. the trace is smooth, differentiable and monotonically increasing in the speed of adjustment,  $h$ , of the actual to the desired rate of investment. We further note that the trace disappears at  $h = \hat{h}$ , when

$$\begin{aligned} (a_1 - 2a_2\bar{g}_6)\hat{h}\bar{g}_6 - b_2\bar{d}_6 &= 0 \\ \Rightarrow \hat{h} &= \frac{b_2\bar{d}_6}{(a_1 - 2a_2\bar{g}_6)\bar{g}_6} > 0 \end{aligned} \quad (3)$$

which, by substituting the values of  $\bar{g}_6$  and  $\bar{d}_6$  from (6), might be expanded as

$$\hat{h} = \frac{b_1 b_2 \sqrt{4 a_2 b_2^2 a_4 - 4 a_2 b_2 a_3 b_3 + b_1^2 a_3^2 - 2 a_1 b_1 b_2 a_3 + a_1^2 b_2^2 + 2 a_2 b_2^2 b_3 - b_1^2 b_2 a_3 + a_1 b_1 b_2^2}}{(2 b_1 a_3 - a_1 b_2) \sqrt{4 a_2 b_2^2 a_4 - 4 a_2 b_2 a_3 b_3 + b_1^2 a_3^2 - 2 a_1 b_1 b_2 a_3 + a_1^2 b_2^2 - 4 a_2 b_2^2 a_4 + 4 a_2 b_2 a_3 b_3 - 2 b_1^2 a_3^2 + 3 a_1 b_1 b_2 a_3 - a_1^2 b_2^2}} \quad (4)$$

□

We define  $\hat{h}$  as the *critical value* of the parameter,  $h$ , and investigate the properties of a solution trajectory to (1) around  $\hat{h}$ . Next, we apply the Andronov-Hopf Bifurcation Theorem to note the following:

**Corollary 2.1.** *For the dynamical system represented by (1),  $h = \hat{h}$  provides a point of Andronov-Hopf bifurcation.*

*Proof.* From lemma 2, the characteristic equation to (1) has purely imaginary roots at  $h = \hat{h}$ . Further, the transversality condition is satisfied from (2). Hence,  $h = \hat{h}$  provides a point of Andronov-Hopf bifurcation. □

**Lemma 3.** *For the dynamical system represented by (1), we can identify specific combination of parameter values for which the Andronov-Hopf bifurcation at  $h = \hat{h}$  is non-degenerate and supercritical (or subcritical), leading to emergence of unique and stable (or unique and unstable) limit cycles.*

*Proof.* Provided in appendix D. □

## 4 Global Stability Properties

We recall that for any  $(g^\circ, d^\circ) \in \text{int } \mathfrak{R}_{++}^2$  as the initial point, the solution to (1) is represented by  $\Theta(t) = (g(t), d(t); g^\circ, d^\circ)$ . We attempt in this section to find out the behavior of this trajectory as  $t \rightarrow \infty$ . Since cyclical possibilities exist only in case 1 among various cases shown in figure 1, we restrict our attention to this case for rest of this analysis.

We define a set  $Q \subseteq \text{int } \mathfrak{R}_{++}^2$  consisting of the rectangular area as follows:

$$Q = \{(g, d) : g \in [0, \bar{g}_3], d \in [0, d_{\max}]\} \quad (5)$$

where  $d_{\max} = (b_1/b_2) \bar{g}_3 + (b_3/b_2) = (b_1 \sqrt{4 a_2 a_4 + a_1^2} + 2 a_2 b_3 + a_1 b_1) / (2 a_2 b_2)$ . It would be evident that  $d_{\max}$  is the point of intersection of  $\dot{d}/d = 0$  with the vertical straight line  $g = \bar{g}_3$  (See figure 2).

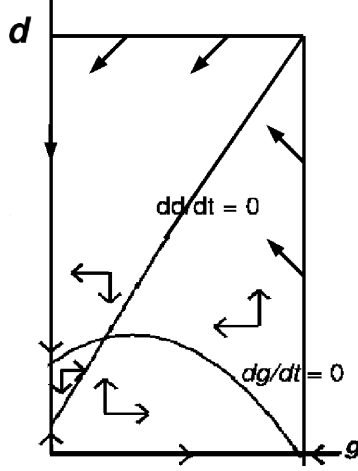

Figure 2: Invariant set  $Q$

We further define  $Q_B \subseteq Q$  comprising the boundary of  $Q$ , such that  $Q_B = \{(g, d) : g = 0, d \in [0, d_{\max}]\} \cup \{(g, d) : g = \bar{g}_3, d \in [0, d_{\max}]\} \cup \{(g, d) : g \in [0, \bar{g}_3], d = 0\} \cup \{(g, d) : g \in [0, \bar{g}_3], d = d_{\max}\}$ . Next, we note the following:

**Lemma 4.** *For the trajectory  $\Theta(t) = (g(t), d(t); g^\circ, d^\circ)$ , the set  $Q$  as defined in (5) is invariant.*

*Proof.* Provided in appendix E. □

**Theorem 1.** *For any  $(g^\circ, d^\circ) \in \text{int } \mathfrak{R}_{++}^2$ , the trajectory,  $\Theta(t)$  either approaches the non-trivial steady state,  $E_6$ , or is a limit cycle surrounding it.*

*Proof.* First, suppose  $(g^\circ, d^\circ) \in \text{int } Q$ . We recall that for case 1 of figure 1,  $E_6$  is the unique steady state in the interior of the positive orthant, and is either a source or a sink. Equations (3) and (4) provide us with a condition to distinguish between the two. In other words,  $h < \hat{h}$  will imply that  $E_6$  is a sink; on the other hand, if  $h > \hat{h}$ , then the steady state  $E_6$  is a source, so that by Poincaré-Bendixson Theorem there must be a limit cycle surrounding  $E_6$ . Next, consider  $(g^\circ, d^\circ) \in \text{int } [\mathfrak{R}_{++}^2 \setminus Q]$ . By construction,  $\Theta(t)$  will eventually enter  $Q$ . Subsequently, it will either converge to  $E_6$  or will approach a limit cycle around  $E_6$ . This completes the proof. □

One should note that the result contained in theorem 1 is robust. It is valid for all set of configuration of parameters where  $h > \hat{h}$ , i.e. the speed of adjustment of the actual to desired rate of investment,  $h$ , exceeds certain threshold level  $\hat{h}$ . It also pertains to any solution with an economically feasible set of initial points.

## 5 Multiple Limit Cycles

In section 3, we noted the emergence of limit cycle from Andronov-Hopf bifurcation. We further noted that this limit cycle could be either attracting or repelling, depending on the configuration of the parameters. In case of a subcritical Andronov-Hopf bifurcation leading to repelling or unstable limit cycle, if the limit cycle is located within an invariant set, then, from Poincaré-Bendixson Theorem we have possibilities of another limit cycle which is attracting.<sup>5</sup>

Consider, for instance, the non-trivial steady state,  $E_6$ , located within an invariant set,  $Q$ , in figure 2. We recall that the steady state  $E_6$  is either a source or a sink, depending on whether the value of the parameter,  $h$ , is greater than or less than the critical value,  $\hat{h}$ . We further note from corollary 2.1 that  $E_6$  undergoes a Andronov-Hopf bifurcation leading to emergence of a small amplitude limit cycle when the bifurcation parameter,  $h$  passes through its critical value,  $\hat{h}$ . Let  $\Gamma_h$  be this limit cycle. Since  $\Gamma_h \in Q$ , it follows from the Jordan curve theorem<sup>6</sup> that  $Q$  is separated into two sets – a compact set,  $A(\Gamma_h)$ , comprising the area enclosed by  $\Gamma_h$  such that  $A(\Gamma_h) \subseteq Q$ , and, the half-open bounded set  $Q \setminus A(\Gamma_h) \equiv \{(g, d) : (g, d) \in Q \text{ \& } (g, d) \notin A(\Gamma_h)\}$ .  $A(\Gamma_h)$  is bounded by  $\Gamma_h$ , the limit cycle resulting due to Poincaré-Andronov-Hopf bifurcation. Suppose further that the configuration of parameters is such that the Andronov-Hopf bifurcation is subcritical, so that  $\Gamma_h$  is repelling. Now we note the following:

**Lemma 5.**  $Q \setminus A(\Gamma_h)$  is non-empty.

*Proof.* We recall that  $Q$  is a compact invariant set, bounded by  $Q_B$ , and that all trajectories with an initial point on  $Q_B$  such that  $g, d \neq 0$  gets pushed towards interior of  $Q$ . In other words,  $Q_B$  cannot be the  $\omega$ -limit set of any trajectory. Since  $\Gamma_h$  is a limit cycle,  $A(\Gamma_h)$  must be a proper subset of  $Q$ , so that  $Q \setminus A(\Gamma_h)$  is non-empty.  $\square$

<sup>5</sup>See Hofbauer & So (1990), Hsu & Hwang (1999) and Yuquan, Zhujun & Chan (1999) for practical examples of emergence of multiple limit cycles by this method.

<sup>6</sup>**The Jordan Curve Theorem.** *Let  $C$  be a simple closed curve in  $S^2$ . Then  $C$  separates  $S^2$  precisely into two components  $W_1$  and  $W_2$ . Each of the sets  $W_1$  and  $W_2$  has  $C$  as its boundary.* (Munkres 2000, Chapter 10)



**Lemma 6.** For  $\Theta(t) = (g(t), d(t); g^\circ, d^\circ)$ ,  $Q \setminus A(\Gamma_h)$  is invariant.

*Proof.* Consider a trajectory,  $\Theta(t)$  starting from an initial point,  $(g^\circ, d^\circ) \in Q \setminus A(\Gamma_h)$ . We have already established, from lemma 4 that for all  $(g^\circ, d^\circ) \in Q$  the solution trajectory,  $\Theta(t)$  cannot cross  $Q_B$ . We further note that, since  $\Gamma_h$  is repelling, for all  $(g^\circ, d^\circ) \in Q \setminus A(\Gamma_h)$ ,  $\Theta(t)$  cannot cross  $\Gamma_h$ . Since  $Q \setminus A(\Gamma_h)$  is constructed on a plane, the solution needs to cross either  $Q_B$  or  $\Gamma_h$  in order to leave  $Q \setminus A(\Gamma_h)$ . Hence,  $Q \setminus A(\Gamma_h)$  is invariant.  $\square$

**Theorem 2.** If the steady state  $E_6$  undergoes a subcritical Poincaré-Andronov-Hopf bifurcation at the critical value of the bifurcation parameter,  $\hat{h}$ , then as the bifurcation parameter  $h$  passes through  $\hat{h}$ , in addition to the small amplitude unstable limit cycle,  $\Gamma_h$ , there exists at least one large amplitude limit cycle which is attracting.

*Proof.* We note that, by construction,  $Q \setminus A(\Gamma_h)$  contains no locally stable fixed point. Hence, from Poincaré-Bendixson Theorem, for any  $(g^\circ, d^\circ) \in Q \setminus A(\Gamma_h)$ ,  $\omega$ -limit set of the solution trajectory,  $\Theta(t)$  will be a closed orbit. Further, the limit cycle,  $\Gamma_h$ , emerging from Andronov-Hopf bifurcation as the bifurcation parameter passes through its critical value is not contained in  $Q \setminus A(\Gamma_h)$ , i.e.  $\Gamma_h \notin Q \setminus A(\Gamma_h)$ . Hence, the  $\omega$ -limit set of  $\Theta(t)$  must be a large amplitude limit cycle which is distinct from  $\Gamma_h$ . We further note that this large amplitude limit cycle is attracting. (See figure 3)  $\square$

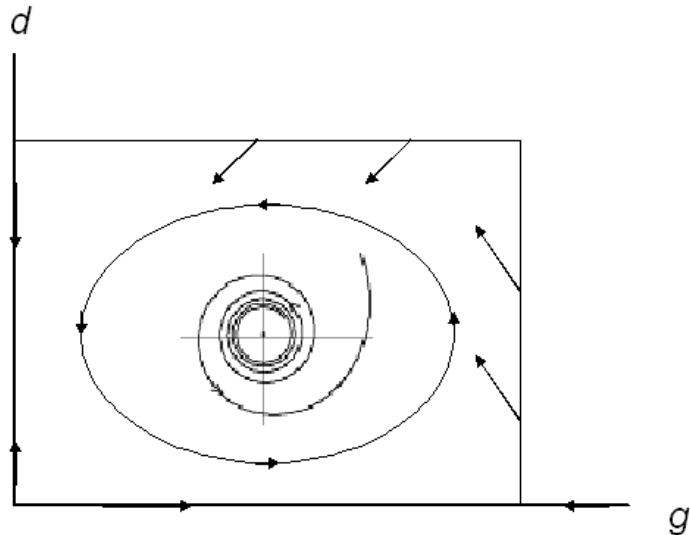

Figure 3: A small amplitude unstable limit cycle surrounded by a large amplitude stable limit cycle

It is clear from theorem 2 that in case of a subcritical Andronov-Hopf bifurcation, the following two kinds of trajectories would emerge:

1. For any  $(g^\circ, d^\circ) \in \text{int}A(\Gamma_h)$  the  $\omega$ -limit set of the solution trajectories would be the steady state,  $E_6$ . This behavior would be similar to Leijonhufvud's (1973) notion of *corridor stability*.
2. For any  $(g^\circ, d^\circ) \in Q \setminus A(\Gamma_h)$ , the  $\omega$ -limit set of the solution trajectories would be a large amplitude limit cycle.

In other words, a subcritical Andronov-Hopf bifurcation leads to possibilities of emergence of multiple limit cycles.

## 6 Conclusions

The above discussion leads us to the following conclusions:

1. For the dynamical system represented by (1), we define a critical value of the parameter  $h$  given by  $\hat{h}$  where we have a non-degenerate Andronov-Hopf bifurcation, leading to emergence of limit cycles.
2. The limit cycle emerging from Andronov-Hopf bifurcation is either stable or unstable; in case it is unstable, from theorem 2, we have another stable limit cycle enclosing the unstable limit cycle.
3. For  $h > \hat{h}$ , from theorem 1, we have a stable limit cycle from an application of Poincaré-Bendixson theorem.

In other words, given  $\hat{h}$ , we have established the existence of a unique stable limit cycle for all  $h \geq \hat{h}$ . We should note that this result for existence of stable limit cycles in planar dynamical systems is more robust than much of the current literature.

Finally, we also point out that these results can be more generally applied to the broader class of economic applications of planar dynamical systems where both Andronov-Hopf bifurcation theorem and Poincaré-Bendixson theorem are applicable. Applicability of this method is not limited by other details of the model chosen in this study.

## Appendix A Steady states

The steady states of the dynamical system represented by (1) are as follows:

$$E_1 : (\bar{g}_1, \bar{d}_1) = (0, 0) \quad (6a)$$

$$E_2 : (\bar{g}_2, \bar{d}_2) = \left( -\frac{\sqrt{4a_2 a_4 + a_1^2} - a_1}{2a_2}, 0 \right) \quad (6b)$$

$$E_3 : (\bar{g}_3, \bar{d}_3) = \left( \frac{\sqrt{4a_2 a_4 + a_1^2} + a_1}{2a_2}, 0 \right) \quad (6c)$$

$$E_4 : (\bar{g}_4, \bar{d}_4) = \left( 0, \frac{b_3}{b_2} \right) \quad (6d)$$

$$E_5 : (\bar{g}_5, \bar{d}_5) = \left( -\frac{\sqrt{4a_2 b_2^2 a_4 - 4a_2 b_2 a_3 b_3 + b_1^2 a_3^2 - 2a_1 b_1 b_2 a_3 + a_1^2 b_2^2} + b_1 a_3 - a_1 b_2}{2a_2 b_2}, \right. \\ \left. -\frac{b_1 \sqrt{4a_2 b_2^2 a_4 - 4a_2 b_2 a_3 b_3 + b_1^2 a_3^2 - 2a_1 b_1 b_2 a_3 + a_1^2 b_2^2} - 2a_2 b_2 b_3 + b_1^2 a_3 - a_1 b_1 b_2}{2a_2 b_2^2} \right) \quad (6e)$$

$$E_6 : (\bar{g}_6, \bar{d}_6) = \left( \frac{\sqrt{4a_2 b_2^2 a_4 - 4a_2 b_2 a_3 b_3 + b_1^2 a_3^2 - 2a_1 b_1 b_2 a_3 + a_1^2 b_2^2} - b_1 a_3 + a_1 b_2}{2a_2 b_2}, \right. \\ \left. \frac{b_1 \sqrt{4a_2 b_2^2 a_4 - 4a_2 b_2 a_3 b_3 + b_1^2 a_3^2 - 2a_1 b_1 b_2 a_3 + a_1^2 b_2^2} + 2a_2 b_2 b_3 - b_1^2 a_3 + a_1 b_1 b_2}{2a_2 b_2^2} \right) \quad (6f)$$

It would be evident that  $E_2 \notin \mathfrak{R}_{++}^2$  since  $\bar{g}_2 < 0$ . Hence we do not discuss  $E_2$  any further in the following sections. Further,  $E_3$  and  $E_4$  are non-negative and lie on the  $g$  and  $d$  axis respectively. Regarding  $E_5$  and  $E_6$ , we note the following:

1. Whenever  $E_5$  and  $E_6$  are real and distinct,  $\dot{d}/d = 0$  must intersect  $\dot{g}/g = 0$  from above at  $E_5$  and from below at  $E_6$ . If  $E_5$  and  $E_6$  are not distinct, then  $\dot{d}/d = 0$  is a tangent to  $\dot{g}/g = 0$  at the point representing the unique non-trivial steady state.
2.  $a_3 b_3 < a_4 b_2$  is a sufficient (though not necessary) condition for the non-trivial steady state  $E_6$  to be inside the real positive orthant,  $\mathfrak{R}_{++}^2$ .
3. For  $g(t) \geq \bar{g}_3$ , we have  $\dot{g}(t) \leq 0$  for all  $d(t) \in \mathfrak{R}^+$ ; in other words, if  $\bar{g}_3 \leq g_{\max}$ , then the feasibility condition  $0 \leq g(t) \leq g_{\max}$  is always satisfied.

## Appendix B Proof of Lemma 1

For any  $(g^\circ, d^\circ) \in \text{int } \mathfrak{R}_{++}^2$  as the initial point, let the solution to (1) be represented by  $\Theta(t) = (g(t), d(t); g^\circ, d^\circ)$ . From (1), we can conclude the following

about the behavior of trajectories in case the initial point is on one of the axes:

- (a)  $\dot{g} > 0, \dot{d} = 0 \forall \{(g^\circ, d^\circ) : g^\circ \in ]0, \bar{g}_3[, d^\circ = 0\}$  as the initial point.
  - (b)  $\dot{g} < 0, \dot{d} = 0 \forall \{(g^\circ, d^\circ) : g^\circ \in ]\bar{g}_3, \infty[, d^\circ = 0\}$  as the initial point.
  - (c)  $\dot{g} = 0, \dot{d} > 0 \forall \{(g^\circ, d^\circ) : g^\circ = 0, d^\circ \in ]0, \bar{d}_4[\}$  as the initial point.
  - (d)  $\dot{g} = 0, \dot{d} < 0 \forall \{(g^\circ, d^\circ) : g^\circ = 0, d^\circ \in ]\bar{d}_4, \infty[\}$  as the initial point.
- (7)

i.e. both the  $g$ -axis and the  $d$ -axis are trajectories. Since trajectories cannot cross each other, this would make the real positive orthant invariant, i.e. trajectories starting from an initial point in the real positive orthant will always remain within it.  $\square$

## Appendix C Parametric conditions for four cases of Figure 1

For  $g, d \neq 0$ , from (1) we have

$$\begin{aligned} \dot{g}(t) \leq 0 &\Leftrightarrow d(t) \geq \frac{a_1}{a_3}g(t) - \frac{a_2}{a_3}\{g(t)\}^2 + \frac{a_4}{a_3} \\ \dot{d}(t) \leq 0 &\Leftrightarrow d(t) \geq \frac{b_1}{b_2}g(t) + b_3 \end{aligned} \quad (8)$$

Depending on the configuration of parameters, we can list four different possibilities exhibiting qualitatively different dynamics:

1. Case 1: Here,  $a_4b_2 - a_3b_3 > 0$ , i.e. intercept of  $\dot{g}/g = 0$  is greater than that of  $\dot{d}/d = 0$ , and  $b_1/b_2 > (a_1 - 2a_2\bar{g}_6)/a_3 > 0$ , i.e.  $\dot{d}/d = 0$  intersects  $\dot{g}/g = 0$  from below in the positively sloped section of the latter curve.  $E_6 \in \text{int}\mathfrak{R}_{++}^2$  is the only steady state in this case inside the real positive orthant.
2. Case 2: Here,  $a_4b_2 - a_3b_3 > 0$ , i.e. intercept of  $\dot{g}/g = 0$  is greater than that of  $\dot{d}/d = 0$ , but unlike case 1,  $(a_1 - 2a_2\bar{g}_6)/a_3 < 0 < b_1/b_2$ , i.e.  $\dot{d}/d = 0$  intersects  $\dot{g}/g = 0$  from below in the negatively sloped section of the latter curve.  $E_6 \in \text{int}\mathfrak{R}_{++}^2$  is the unique steady state inside the real positive orthant.
3. Case 3: Here,  $a_4b_2 - a_3b_3 < 0$ , i.e. intercept of  $\dot{g}/g = 0$  is less than that of  $\dot{d}/d = 0$ , and  $(a_1 - 2a_2\bar{g}_5)/a_3 > b_1/b_2 > 0 > (a_1 - 2a_2\bar{g}_6)/a_3$ , i.e.  $\dot{d}/d = 0$  intersects  $\dot{g}/g = 0$  from below at  $E_5$  when the latter is sloping upward, and from above at  $E_6$  when the latter is sloping downward. In this case,  $E_5, E_6 \in \text{int}\mathfrak{R}_{++}^2$ , i.e.  $\dot{d}/d = 0$  intersects  $\dot{g}/g = 0$  twice in the interior of the real positive orthant.
4. Case 4: Here,  $a_4b_2 - a_3b_3 < 0$ , i.e. intercept of  $\dot{g}/g = 0$  is less than that of  $\dot{d}/d = 0$ , and, unlike case 3,  $E_5, E_6 \notin \text{int}\mathfrak{R}_{++}^2$  so that there does not exist any

steady state in the interior of the real positive orthant. Since we are interested in only the real positive orthant, we do not discuss case 4 any further in the rest of our discussion.

## Appendix D Proof of Lemma 3

In order to establish that this Andronov-Hopf bifurcation point is non-degenerate, and to determine the stability of the limit cycles emerging from this bifurcation, we reduce our dynamical system represented by (1) to its topological normal form, using a method outlined by (Edneral 2007), (Wiggins 1990) and (Kuznetsov 1997, Kuznetsov 2006). We implement this method by writing a program, using computer algebra system Maxima (see program 1 in appendix F). The actual algorithm consists of the steps given below:

1. We perform a linear transformation of coordinates from  $(g(t), d(t))$  to the new plane,  $(x_1(t), x_2(t))$  such that  $g(t) = x_1(t) + \bar{g}_6$ , and  $d(t) = x_2(t) + \bar{d}_6$ . With this shift, the steady state,  $E_6 : (\bar{g}_6, \bar{d}_6)$  is placed at the origin, and the dynamical system (1) can be represented as

$$\begin{aligned}\dot{x}_1(t) &= h [-a_2 \{x_1(t)\}^3 + a_6 \{x_1(t)\}^2 + a_5 x_1(t) - a_3 x_1(t) x_2(t) - a_7 x_2(t)] \\ \dot{x}_2(t) &= b_4 x_1(t) + b_1 x_1(t) x_2(t) - b_5 x_2(t) - b_3 \{x_2(t)\}^2\end{aligned}\tag{9}$$

where

$$a_5 = \frac{2 b_1 a_3 s_1 - a_1 b_2 s_1 - 4 a_2 b_2^2 a_4 + 4 a_2 b_2 a_3 b_3 - 2 b_1^2 a_3^2 + 3 a_1 b_1 b_2 a_3 - a_1^2 b_2^2}{2 a_2 b_2^2}$$

$$a_6 = -\frac{3 s_1 - 3 b_1 a_3 + a_1 b_2}{2 b_2}$$

$$a_7 = \frac{a_3 (s_1 - b_1 a_3 + a_1 b_2)}{2 a_2 b_2}$$

$$b_4 = \frac{b_1 (b_1 s_1 + 2 a_2 b_2 b_3 - b_1^2 a_3 + a_1 b_1 b_2)}{2 a_2 b_2^2}$$

$$b_5 = \frac{b_1 s_1 + 2 a_2 b_2 b_3 - b_1^2 a_3 + a_1 b_1 b_2}{2 a_2 b_2}$$

$$s_1 = \sqrt{4 a_2 b_2^2 a_4 - 4 a_2 b_2 a_3 b_3 + b_1^2 a_3^2 - 2 a_1 b_1 b_2 a_3 + a_1^2 b_2^2}$$

2. For the transformed dynamical system represented by (9), we take a Taylor series expansion around the steady state represented by the origin. The resulting expression can be represented in matrix notation as

$$\dot{X} = A(h) X + F(X, h)\tag{10}$$

where  $X = \begin{pmatrix} x_1 \\ x_2 \end{pmatrix}$  is a column vector of the two variables, and  $A(h)$  is the jacobian matrix so that  $A(h)X$  represents the linear part of the Taylor series expansion, i.e.

$$A(h) = \begin{pmatrix} a_5h & -a_7h \\ b_4 & -b_5 \end{pmatrix} \quad (11)$$

and  $F(X, h)$  represents the non-linear terms of the Taylor series expansion, starting with at least quadratic terms, such that  $F(X, h) = O(\|x\|^2) + O(\|x\|^3) + \dots$

3. Next, we calculate the eigenvalues,  $\vartheta(h)$  and  $\overline{\vartheta(h)}$  of the jacobian matrix,  $A(h)$  from (11):

$$\vartheta(h), \overline{\vartheta(h)} = \frac{1}{2} \left\{ (a_5h - b_5) \pm \sqrt{a_5^2h^2 + (2a_5b_5 - 4a_7b_4) + b_5^2} \right\}$$

so that real part of the eigenvalues is expressed as  $\text{Re } \vartheta(h) = a_5h - b_5$ . Further,

$$\left. \frac{d(\text{Re } \vartheta(h))}{dh} \right|_{h=0} = a_5 > 0$$

i.e. *transversality condition* is satisfied.

4. We now recalculate the critical value,  $\hat{h}$ , of the bifurcation parameter,  $h$ . This would correspond to the right hand side of (4), expressed in terms of the new parameters defined above. Thus, we have

$$\hat{h} = \frac{b_5}{a_5} \quad (12)$$

Substituting the value of  $\hat{h}$  from (12) into (11), we have the jacobian at the critical value of bifurcation parameter:

$$A(\hat{h}) = \begin{pmatrix} b_5 & -\frac{a_7b_5}{a_5} \\ b_4 & -b_5 \end{pmatrix} \quad (13)$$

Further, we have Determinant  $(A(\hat{h})) = (b_4b_5a_7)/a_5 - b_5^2$ . We define  $\omega$  such that  $\omega^2 = \text{Determinant}(A(\hat{h}))$ . We now express  $A(\hat{h})$  from (13) in terms of  $\omega$ .

$$A(\hat{h}) = \begin{pmatrix} b_5 & -\frac{a_7b_5}{a_5} \\ \frac{a_5(b_5^2 + \omega^2)}{a_7b_5} & -b_5 \end{pmatrix} \quad (14)$$

The eigenvalues of  $A(\hat{h})$  evaluated at the critical value of the bifurcation parameter can now be expressed as  $\vartheta(\hat{h}), \overline{\vartheta(\hat{h})} = \pm i\omega$ .

5. We now calculate the eigenvector of  $A(\hat{h})$  with respect to  $\vartheta(\hat{h})$  and call it  $q$ , where

$$q = \begin{pmatrix} ia_7b_5\omega + a_7b_5^2 \\ a_5\omega^2 + a_5b_5^2 \end{pmatrix}$$

i.e.  $A(\hat{h})q = \vartheta(\hat{h})q$ . It would be evident that eigenvector of  $A(\hat{h})$  with respect to  $\overline{\vartheta(\hat{h})}$  would be  $\bar{q}$ , where  $\bar{q}$  is the complex conjugate of  $q$ , so that  $A(\hat{h})\bar{q} = \overline{\vartheta(\hat{h})}\bar{q}$ .

6. We next calculate  $A^T(\hat{h})$ , the transpose of  $A(\hat{h})$ :

$$A^T(\hat{h}) = \begin{pmatrix} b_5 & \frac{a_5(b_5^2 + \omega^2)}{a_7b_5} \\ -\frac{a_7b_5}{a_5} & -b_5 \end{pmatrix} \quad (15)$$

We note that the eigenvalues of  $A^T(\hat{h})$  would be the same as those of  $A(\hat{h})$  and might be represented as  $\vartheta(\hat{h})$  and  $\overline{\vartheta(\hat{h})}$ .

7. We next calculate the eigenvector of  $A^T(\hat{h})$  with respect to  $\overline{\vartheta(\hat{h})}$  and call it  $p$ , i.e.

$$p = \begin{pmatrix} 1 \\ \frac{a_7b_5}{ia_5\omega - a_5b_5} \end{pmatrix}$$

i.e.  $A^T(\hat{h})p = \overline{\vartheta(\hat{h})}p$ . It would be clear that the eigenvector of  $A^T(\hat{h})$  with respect to  $\vartheta(\hat{h})$  would be  $\bar{p}$ , i.e.  $A^T(\hat{h})\bar{p} = \vartheta(\hat{h})\bar{p}$ .

8. We note that the scalar product of  $p$  and  $q$  is given by

$$\langle p, q \rangle = \frac{2ia_7b_5^2\omega - 2a_7b_5\omega^2}{b_5 + i\omega}$$

We next normalize  $p$  with respect to  $q$  by suitably transforming from  $p$  to  $\hat{p}$ , so that the scalar product of  $\hat{p}$  and  $q$  is one, i.e.  $\langle \hat{p}, q \rangle = 1$ . This can be achieved

by multiplying the column vector  $p$  with the reciprocal of the conjugate of the scalar product of  $p$  and  $q$ , i.e.

$$\hat{p} \equiv p \cdot \frac{1}{\langle p, q \rangle}$$

This leaves us with the following:

$$\hat{p} = \begin{pmatrix} \frac{\omega - b_5}{2a_7b_5\omega^2 + 2a_7b_5^2\omega} \\ \frac{1}{2a_5\omega^2 + 2a_5b_5\omega} \end{pmatrix} \quad (16)$$

We now note that  $\langle \hat{p}, q \rangle = 1$ .

9. Next, we perform a complex linear transformation,  $z = \langle \hat{p}, x \rangle$  so that  $x = zq + \bar{z}\bar{q}$ . We should note that  $x = zq + \bar{z}\bar{q} \Leftrightarrow \langle \hat{p}, x \rangle = z\langle \hat{p}, q \rangle + \bar{z}\langle \hat{p}, \bar{q} \rangle \Leftrightarrow \langle \hat{p}, x \rangle = z$  [ $\langle \hat{p}, q \rangle = 1$ ,  $\langle \hat{p}, \bar{q} \rangle = 0$ ]. The transformation from  $(x_1, x_2)$  to  $z$  might be viewed as a combination of two transformations,  $y = T(h)x$  and  $z = y_1 + iy_2$ . It would be clear that the components  $(y_1, y_2)$  are the coordinates of  $(x_1, x_2)$  in the real eigenbasis of  $A(h)$  composed by  $(2\text{Re } q, -2\text{Im } q)$ . In this basis, the matrix  $A(h)$  has its canonical real (Jordan) form

$$J(h) = T(h)A(h)T^{-1}(h) = \begin{pmatrix} \text{Re } \vartheta(h) & -\omega(h) \\ \omega(h) & \text{Re } \vartheta(h) \end{pmatrix}$$

This complex linear transformation imposes a linear relationship between  $(x_1, x_2)$  and the real and imaginary parts of  $z$ . With this transformation, the dynamical system represented by (9) is now reduced to a single differential equation:

$$\dot{z} = \vartheta(h)z + g(z, \bar{z}, h) \quad (17)$$

where  $g(z, \bar{z}, h) = \langle p(h), F(zq(h) + \bar{z}\bar{q}(h), \alpha) \rangle$ .

To perform this transformation, we first represent the right hand side of (9) by  $F_1(x_1, x_2)$  and  $F_2(x_1, x_2)$  respectively. Next, we make the following substitution:

$$\begin{aligned} x_1 &= zq_1 + w\bar{q}_1 = (a_7b_5^2 + a_7b_5\omega)z + (a_7b_5^2 - a_7b_5\omega)w \\ x_2 &= zq_2 + w\bar{q}_2 = (a_5b_5^2 + a_5\omega^2)(z + w) \end{aligned} \quad (18)$$

It might be noted that in the substitution made above in (18), we introduce an additional variable,  $w$  instead of  $\bar{z}$  in order to simplify the implementation of the algorithm in a symbolic manipulation software like Maxima. (See, for



instance, Kuznetsov 1997, page 103, footnote 5). Substituting from (18), we have

$$\begin{aligned}
& F_1(zq_1 + w\bar{q}_1, zq_2 + w\bar{q}_2) \\
&= \frac{b_5}{a_5} [-a_3 \{(\imath a_7 b_5 \omega + a_7 b_5^2) z + (a_7 b_5^2 - \imath a_7 b_5 \omega) w\} (a_5 \omega^2 + a_5 b_5^2) (z + w) \\
&\quad - a_7 (a_5 \omega^2 + a_5 b_5^2) (z + w) - a_2 \{(\imath a_7 b_5 \omega + a_7 b_5^2) z + (a_7 b_5^2 - \imath a_7 b_5 \omega) w\}^3 \\
&\quad + a_6 \{(\imath a_7 b_5 \omega + a_7 b_5^2) z + (a_7 b_5^2 - \imath a_7 b_5 \omega) w\}^2 + a_5 \{(\imath a_7 b_5 \omega + a_7 b_5^2) z \\
&\quad + (a_7 b_5^2 - \imath a_7 b_5 \omega) w\}]
\end{aligned} \tag{19}$$

and

$$\begin{aligned}
& F_2(zq_1 + w\bar{q}_1, zq_2 + w\bar{q}_2) \\
&= -b_2 \{(a_5 \omega^2 + a_5 b_5^2) (z + w)\}^2 + b_1 \{(\imath a_7 b_5 \omega + a_7 b_5^2) z + (a_7 b_5^2 - \imath a_7 b_5 \omega) w\} \\
&\quad \{(a_5 \omega^2 + a_5 b_5^2) (z + w)\} - b_5 (a_5 \omega^2 + a_5 b_5^2) (z + w) + b_4 \{(\imath a_7 b_5 \omega + a_7 b_5^2) z \\
&\quad + (a_7 b_5^2 - \imath a_7 b_5 \omega) w\}
\end{aligned} \tag{20}$$

We define a matrix  $F$  such that

$$F = \begin{pmatrix} F_1(zq_1 + w\bar{q}_1, zq_2 + w\bar{q}_2) \\ F_2(zq_1 + w\bar{q}_1, zq_2 + w\bar{q}_2) \end{pmatrix} \tag{21}$$

and a new complex-valued function  $G(z, w)$  such that

$$G(z, w) = \langle \hat{p}, F \rangle \tag{22}$$

where  $G$  can be calculated by a scalar multiplication of  $\hat{p}$  from (16) with  $F$  from (21).<sup>7</sup>

10. Next, we calculate the *First Lyapunov Exponent*,  $\ell_1(\hat{h})$  as follows:

$$\ell_1(\hat{h}) = \frac{1}{2\omega^2} \operatorname{Re} \left( \imath \frac{\partial^2 G}{\partial z^2} \Big|_{z=0, w=0} \frac{\partial^2 G}{\partial z \partial w} \Big|_{z=0, w=0} + \omega \frac{\partial^3 G}{\partial z \partial z \partial w} \Big|_{z=0, w=0} \right) \tag{23}$$

The computer algebra system, Maxima, calculates the value of first Lyapunov exponent of our system as:

$$\begin{aligned}
\ell_1(\hat{h}) = & -\frac{1}{2a_5^2 \omega^3} \{ b_5 (b_5^2 + \omega^2) (3a_2 a_5 a_7^2 b_5^2 \omega^2 + a_3 a_5 a_6 a_7 b_5^2 \omega^2 - a_5^3 a_7 b_1 b_2 \omega^2 \\
& - a_3^2 a_5^2 b_5^2 \omega^2 - a_3 a_5^3 b_2 b_5 \omega^2 + 2a_5^4 b_2^2 \omega^2 - 2a_6^2 a_7^2 b_5^4 + a_5 a_6 a_7^2 b_1 b_5^3 + a_5^2 a_7^2 b_1^2 b_5^2 \\
& + 3a_3 a_5 a_6 a_7 b_5^4 - 3a_5^3 a_7 b_1 b_2 b_5^2 - a_3^2 a_5^2 b_5^4 - a_3 a_5^3 b_2 b_5^3 + 2a_5^4 b_2^2 b_5^2) \}
\end{aligned} \tag{24}$$

---

<sup>7</sup>The actual output of  $G$  is too long to be displayed here. Those interested might obtain this as part of the output by running program 1 on GNU computer algebra system, Maxima.

11. Once we have calculated the value of the *First Lyapunov Exponent* from (24) and established that it is non-zero (i.e. non-degeneracy conditions are satisfied), we can reduce (17) to its topological normal form using a series of transformations, including an invertible parameter-dependent shift of complex coordinates, a linear time rescaling and a non-linear time reparametrization, and elimination of terms of degree greater than four from the Taylor series (cf. Kuznetsov 1997, page 94-100). In this case, (17) can be represented in the topological normal form as:

$$\begin{pmatrix} \dot{y}_1 \\ \dot{y}_2 \end{pmatrix} = \begin{pmatrix} \alpha & -1 \\ 1 & \alpha \end{pmatrix} \begin{pmatrix} y_1 \\ y_2 \end{pmatrix} + \varpi (y_1^2 + y_2^2) \begin{pmatrix} y_1 \\ y_2 \end{pmatrix} \quad (25)$$

where  $\varpi = \text{sign} \left( \ell_1 \left( \hat{h} \right) \right) = \pm 1$ ,  $\alpha = \frac{\text{Re } \vartheta(h)}{\omega(h)} \in \mathfrak{R}$  and  $y = (y_1, y_2)^T \in \mathfrak{R}^2$ .

The normal form represented by (25) is locally topologically equivalent to the original dynamical system represented by (1) near the steady state,  $E_6$ . For  $\varpi = +1$ , the normal form has a steady state at the origin, which is asymptotically stable for  $\alpha \leq 0$  and unstable for  $\alpha > 0$ ; in the latter case, a unique and stable limit cycle with radius  $\sqrt{\alpha}$  will emerge. This is the case of a *supercritical Andronov-Hopf bifurcation*. Similarly, for  $\varpi = -1$ , the normal form has a steady state at the origin, which is asymptotically stable for  $\alpha < 0$  and unstable for  $\alpha \geq 0$ ; in the former case, a unique and unstable limit cycle will emerge. This is the case of a *subcritical Andronov-Hopf bifurcation*.  $\square$

## Appendix E Proof of Lemma 4

Consider a trajectory  $\Theta(t)$  starting from an initial point located on the boundary,  $Q_B$  of  $Q$ , i.e.  $(g^\circ, d^\circ) \in Q_B$ . We recall from (7) that the  $g$ -axis and the  $d$ -axis are both trajectories. In particular, since  $E_1(0, 0)$  is a steady state,

$$(g^\circ, d^\circ) = E_1(0, 0) \Rightarrow \Theta(t) = E_1(0, 0) \quad \forall t \in \mathfrak{R} \quad (26)$$

Since  $E_3(\bar{g}_3, 0)$  and  $E_4(0, \bar{d}_4)$  are also steady states, by same logic,

$$(g^\circ, d^\circ) = E_3(\bar{g}_3, 0) \Rightarrow \Theta(t) = E_3(\bar{g}_3, 0) \quad \forall t \in \mathfrak{R} \quad (27)$$

$$(g^\circ, d^\circ) = E_4(0, \bar{d}_4) \Rightarrow \Theta(t) = E_4(0, \bar{d}_4) \quad \forall t \in \mathfrak{R} \quad (28)$$

In other words, if the initial point is either on  $E_1$ ,  $E_2$  or  $E_3$  then the trajectory will remain at the initial point. Further, from (7), if the initial point is on either  $g$ -axis or  $d$ -axis, but not on one of the steady states, it will approach  $E_3$  and  $E_4$  respectively.

On the other hand, for  $(g^\circ, d^\circ) \in \{(g, d) : g = \bar{g}_3, d \in ]0, d_{\max}]\}$ , we have  $\dot{g} < 0$  and  $\dot{d} > 0$ ; whereas for  $(g^\circ, d^\circ) \in \{(g, d) : g \in ]0, \bar{g}_3[\}$  we have  $\dot{g} < 0$  and  $\dot{d} < 0$ ; i.e. in both cases the trajectories would be pushed towards interior of  $Q$ . To summarize, for any  $(g^\circ, d^\circ) \in Q_B$ , the trajectories either remain on  $Q_B$  or are pushed towards the interior of  $Q$ ; in no case do the trajectories leave  $Q$ . [See figure 2] In addition, since  $Q$  is constructed on a plane, i.e.  $Q \subseteq \mathfrak{R}_{++}^2$ , no trajectory with an initial point in the interior of  $Q$  can leave  $Q$  without crossing  $Q_B$ . This completes the proof of invariance of  $Q$ .  $\square$

## Appendix F Program Code

The following program code is written for Maxima version 5.21.1, using Lisp SBCL 1.0.29.11.debian, distributed under the GNU Public License.

<http://maxima.sourceforge.net>

---

Program 1: To find first lyapunov exponent of Andronov-Hopf bifurcation

---

```

F1: (a[1]*g - a[2]*g^2 - a[3]*d + a[4])*h*g;
F2: (b[1]*g - b[2]*d + b[3])*d;
assume(a[1]>0, a[2]>0, a[3]>0, a[4]>0, b[1]>0, b[2]>0,
        b[3]>0, h>0, g>0, d>0)$
assume (a[1]*b[2] > a[3]*b[1])$
assume (a[4]*b[2] > a[3]*b[3])$
sol: algsys ([F1=0, F2=0], [g,d])$
u: rhs(sol[6][1])$
v: rhs(sol[6][2])$
F3: fullratsimp(subst (x[1]+u, g, F1))$
F4: fullratsimp(subst (x[1]+u, g, F2))$
F5: fullratsimp(subst (x[2]+v, d, F3))$
F6: fullratsimp(subst (x[2]+v, d, F4))$
F7: expand (F5);
F8: expand (F6);
s1: sqrt(4*a[2]*b[2]^2*a[4]-4*a[2]*b[2]*a[3]*b[3]+b[1]^2*a[3]^2
        -2*a[1]*b[1]*b[2]*a[3]+a[1]^2*b[2]^2)$
F9: subst (s,s1,F7);
F10: subst (s,s1,F8);
cx1: (factor(coeff (F9, x[1]) + a[3]*h*x[2]))/h $
cx12: (factor(coeff (F9, x[1]^2)))/h $
cx2: (factor(coeff (F9, x[2]) + a[3]*h*x[1])) /h $
F11: fullratsimp((a[5]*x[1] + a[6]*x[1]^2 - a[2]*x[1]^3

```

```

- a[7]*x[2] - a[3]*x[1]*x[2])*h );
ratsimp(F9 - subst([a[5]=cx1, a[6]=cx12, a[7]= -cx2], F11)) ;
dx1: factor(coeff(F10, x[1]) - b[1]*x[2]) $
dx2: factor(coeff(F10,x[2]) - b[1]*x[1]) $
F12: fullratsimp(b[4]*x[1] - b[5]*x[2] - b[2]*x[2]^2
+ b[1]*x[1]*x[2]);
ratsimp(F10 - subst([b[4]=dx1, b[5]=-dx2], F12));
J: jacobian ([F11,F12], [x[1],x[2]])$
J1: subst ([x[1]=0, x[2]=0], J)$
tr: mat_trace (J1)$
h1: solve ([tr=0], [h])$
J2: subst ([h=rhs(h1[1])], J1)$
%Delta: determinant (J2)$
rule1: %omega^2 = %Delta $
m1: solve (rule1, b[4]) $
m: rhs (m1[1]) $
J3: ratsimp(subst ([b[4]=m], J2));
Q: eigenvectors (J3);
q: fullratsimp(denom(Q[3][2])*transpose(Q[3]));
J4: transpose (J3)$
P: eigenvectors (J4);
p1: transpose(P[2])$
innerproduct(p1,q)$
inner: conjugate (innerproduct (p1,q))$
p: fullratsimp(p1*(1/inner));
innerproduct (p,q);
F13: subst ([h=rhs(h1[1])], F11)$
F14: subst ([h=rhs(h1[1])], F12)$
CLT1: x[1] = (z*q[1] + w*(conjugate(q[1]))) [1];
CLT2: x[2] = (z*q[2] + w*(conjugate(q[2]))) [1];
F15: subst ([CLT1,CLT2], F13);
F16: subst ([CLT1,CLT2], F14);
FF: matrix ([F15],[F16]);
G: innerproduct (p,FF);
g1: fullratsimp(diff (G,z,2))$
g[20]: fullratsimp(subst ([z=0, w=0], g1));
g3: fullratsimp(diff(G,z,1))$
g4: fullratsimp(diff(g3,w,1))$
g[11]: fullratsimp (subst ([z=0,w=0],g4));

```

```

g6: fullratsimp (diff(g1,w,1))$
g[21]: fullratsimp (subst ([z=0,w=0],g6));
c[1]: %i*g[20]*g[11] + %omega * g[21];
l[1]: factor((1/(2* %omega^2)) * realpart(c[1]));

```

---

## References

- Asada, T., Chen, P., Chiarella, C. & Flaschel, P. (2006), ‘Keynesian dynamics and the wage-price spiral: A baseline disequilibrium model’, *Journal of Macroeconomics* **28**(1), 90–130.
- Asada, T. & Yoshida, H. (2003), ‘Coefficient Criterion for Four-dimensional Hopf Bifurcations: A Complete Mathematical Characterization and Applications to Economic Dynamics’, *Chaos, Solitons and Fractals* **18**, 525–536.
- Barnett, W. A. & He, Y. (1998), Bifurcations in Continuous-Time Macroeconomic Systems, Macroeconomics 9805018, EconWPA.  
\*<http://ideas.repec.org/p/wpa/wuwpma/9805018.html>
- Barnett, W. & He, Y. (2006), Existence of Bifurcation in Macroeconomic Dynamics: Grandmont was Right, Working papers series in theoretical and applied economics 200610, University of Kansas, Department of Economics.  
\*<http://ideas.repec.org/p/kan/wpaper/200610.html>
- Benhabib, J. & Miyao, T. (1981), ‘Some New Results on the Dynamics of the Generalized Tobin Model’, *International Economic Review* **22**(3), 589–96.
- Benhabib, J. & Nishimura, K. (1979), ‘The Hopf Bifurcation and the Existence and Stability of Closed Orbits in Multisector Models of Optimal Economic Growth’, *Journal of Economic Theory* **21**, 421–444.
- Chiarella, C. & Flaschel, P. (2000), *The Dynamics of Keynesian Monetary Growth: Macro Foundations*, Cambridge University Press.
- Chiarella, C., Flaschel, P. & Franke, R. (2005), *Foundations for a Disequilibrium Theory of the Business Cycle: Qualitative Analysis and Quantitative Assessment*, Cambridge University Press, Cambridge, U.K.
- Datta, S. (2012), Cycles and crises in a model of debt-financed investment-led growth, MPRA Paper 50200, University Library of Munich, Germany.  
\*<http://mpra.ub.uni-muenchen.de/id/eprint/50200>

- Edneral, V. F. (2007), An Algorithm for Construction of Normal Forms, *in* V. G. Ganzha, E. W. Mayr & E. V. Vorozhtsov, eds, ‘CASC’, Vol. 4770 of *Lecture Notes in Computer Science*, Springer, pp. 134–142.
- Franke, R. (1992), ‘Stable, Unstable and Persistent Cyclical Behavior in a Keynes-Wicksell Monetary Growth Model’, *Oxford Economic Papers* **44**, 242–256.
- Hofbauer, J. & So, J. W. H. (1990), ‘Multiple Limit Cycles for Predator-prey Models’, *Mathematical Biosciences* **99**(1), 71–75.
- Hsu, S.-B. & Hwang, T.-W. (1999), ‘Hopf Bifurcation for a Predator-prey System of Holling and Leslie Type’, *Taiwanese Journal of Mathematics* **3**(1), 35–53.
- Kind, C. (1999), ‘Remarks on the Economic Interpretation of Hopf Bifurcations’, *Economics Letters* **62**, 147–154.
- Kuznetsov, Y. A. (1997), *Elements of Applied Bifurcation Theory*, Vol. 112 of *Applied Mathematical Sciences*, second edn, Springer-Verlag, New York.
- Kuznetsov, Y. A. (2006), ‘Andronov-Hopf bifurcation’, *Scholarpedia* **1**(10), 1858.  
\*[http://www.scholarpedia.org/article/Andronov-Hopf\\_bifurcation](http://www.scholarpedia.org/article/Andronov-Hopf_bifurcation)
- Leijonhufvud, A. (1973), ‘Effective Demand Failures’, *Swedish Journal of Economics* **75**, 27–48.
- Minagawa, J. (2007), A determinantal criterion of Hopf bifurcations and its application to economic dynamics, *in* T. Asada & T. Ishikawa, eds, ‘Time and Space in Economics’, Springer, pp. 160–172.
- Munkres, J. R. (2000), *Topology*, second edn, Pearson Education, Inc.
- Velupillai, K. (2006), ‘A Disequilibrium Macrodynamical Model of Fluctuations’, *Journal of Macroeconomics* **28**(4), 752–767.
- Wiggins, S. (1990), *Introduction to Applied Nonlinear Dynamical Systems and Chaos*, Springer-Verlag, New York, Inc.
- Yuquan, W., Zhujun, J. & Chan, K. (1999), ‘Multiple Limit Cycles and Global Stability in Predator-Prey Model’, *Acta Mathematicae Applicatae Sinica* **15**(2), 206–219.