



Munich Personal RePEc Archive

A Novel Integrated Algebraic/Geometric Approach to the Solution of Two by Two Games with Dominance Principle

Zola, Maurizio Angelo

29 April 2024

Online at <https://mpra.ub.uni-muenchen.de/121763/>
MPRA Paper No. 121763, posted 22 Aug 2024 19:23 UTC

A NOVEL INTEGRATED ALGEBRAIC/GEOMETRIC APPROACH TO THE SOLUTION OF TWO BY TWO GAMES WITH DOMINANCE PRINCIPLE

MAURIZIO ANGELO ZOLA^{1,*}

¹University of Bergamo

Department of Engineering and Applied Sciences
G. Marconi 5, I-24044 Dalmine (BG), Italy

Department of Mathematics, Statistics, Computer Science and Applications
Dei Caniana 2, I-24127 Bergamo (BG), Italy

*maurizio.zola@gmail.com

Submitted for publication

Abstract

The classical mixed strategies non-cooperative solution of a two person – two move game is recalled by paying attention to the different proposed methods and to the properties of the so found solutions. The non-cooperative equilibrium point is determined by a new geometric approach based on the dominance principle. Starting from the algebraic bi-linear form of the expected payoffs of the two players in the (x, y) domain of the probabilistic distribution on the pure strategies, the two equations are studied as surfaces in the 3D space on the basis of the sound theory of the quadratic forms. The study of the properties of the quadric is performed by classifying the bi-linear form as pertaining to a classical hyperbolic paraboloid and the relationship between its geometric properties and the probabilistic distribution on the pure strategies is found. The application of the dominance principle allows to choose the equilibrium point among the classical solutions avoiding the ambiguity due to their non-interchangeability and a conjecture about the uniqueness of the solution is proposed in order to solve the problem of the existence and uniqueness of the non-cooperative solution of a two-by-two game. The uniqueness of the non-cooperative solution could be used as a starting point to find out the cooperative solution of the game too.

Keywords: *Dominance principle; General sum game; two person-two move game.*

1 Introduction

The main references for the development of the present paper are the master paper by Nash [?] and the texts of Luce and Raiffa [?], Owen [?], Straffin [?], Maschler et al. [?].

As it is well known the mixed strategies method to find the solution of a game is suitable only for repeatable games. A mixed strategy for a player is defined as the probability distribution on the set of his pure strategies [?]; the expected payoff from a mixed strategy is defined as the corresponding probability-weighted average of the payoffs from its constituent pure strategies [?]. The search of the non-cooperative solution with the mixed strategies could bring to find more than one equilibrium point, but these equilibrium points represent the acceptable non-cooperative solution of the game only if they are equivalent and interchangeable [?,?].

To solve the problem it is proposed to use the dominance principle as the only tool to find the non-cooperative solution of a game in the mixed strategies: a rational player should never play a dominated strategy [?,?]. Straffin [?] argues that the dominance principle is cogent for individual rationality whereas the Pareto-optimality is cogent for the group rationality, thus there is a conflict between the dominance principle and the Pareto-optimality. The individual rationality is here considered cogent for the non-cooperative solution of a game, thus the dominance principle is suitable to find the solution.

On the other hand, the maximin [?] value of any particular player is unaffected by the elimination of his dominated strategies, whether those strategies are weakly or strictly dominated; moreover the iterated elimination of weakly dominated strategies does not lead to the creation of new equilibria (Maschler et al. [?]).

The paper is devoted to the study of the non-cooperative solution of a two person-two move game with no dominated pure strategies, therefore it is not considered the trivial case that can be solved by the elimination of all the dominated strategies.

In Part 2 of the paper it is proposed to look for the non-cooperative solution of a game by only applying the dominance principle on the mixed strategies and the relationship is studied among the two classical mixed strategies, prudential and Nash strategy, and the expected payoff. Moreover the relationship among the coefficients of the game matrix and the values of the expected payoff is discussed and a very simple rule is found in order to evaluate the dominating strategy and the relevant value of the game for both players. It is identified which conditions should be verified in order to have equivalence and interchangeability of different equilibrium points of a game.

In Part 3 three numerical examples are discussed to show the application of the dominance principle and in the case of a game studied by Nash [?] a different solution is proposed by applying the dominance principle.

Part 4 presents the geometric interpretation of the bi-linear formula of the expected payoff as a 3D hyperbolic paraboloid: the same solution as per the algebraic way is found, but the geometric properties of the paraboloid allow to understand more easily the meaning of the mixed strategies and of the dominance principle and, moreover, to demonstrate the uniqueness of the solution.

In Part 5, in order to show its powerful meaning, the geometric method is applied to the already discussed examples and a supplementary fourth example is solved showing that with the geometric method it is possible to find the equilibrium point of a game also when the algebraic method fails.

The conclusion summarizes the main features of the geometric method recognizing it as a powerful tool to find the non-cooperative solution of a two by two general sum game.

2 Classical noncooperative solution of the normal form

2.1 Theory

As it is well known the normal form of the two-by-two game is the following one:

Table 1

		Moves of player B	
		y_1	y_2
Moves of player A	x_1	a_{11}, b_{11}	a_{12}, b_{12}
	x_2	a_{21}, b_{21}	a_{22}, b_{22}

$$x = (x_1, x_2) = (x, 1 - x) \quad (1)$$

and

$$y = (y_1, y_2) = (y, 1 - y) \quad (2)$$

are the vectors of the probability distribution on the moves respectively for player A and B , with the constraints

$$0 \leq x \leq 1 \quad (3)$$

and

$$0 \leq y \leq 1 \quad (4)$$

Associated to each possible outcome of the game is a collection of numerical payoffs, one to each player.

The expected payoff for each player is then given by:

$$z_A = (a_{11} + a_{22} - a_{12} - a_{21})xy + (a_{12} - a_{22})x + (a_{21} - a_{22})y + a_{22} = A_1xy + A_2x + A_3y + A_4 \quad (5)$$

$$z_B = (b_{11} + b_{22} - b_{12} - b_{21})xy + (b_{12} - b_{22})x + (b_{21} - b_{22})y + b_{22} = B_1xy + B_2x + B_3y + B_4 \quad (6)$$

These formulas will be used throughout the paper from here on.

In order to find maximum and minimum points [?] the first derivative of the expected payoff should be calculated and the Hessian should be studied, but the finding is that, if the condition of the existence of the mixed strategies is verified, the Hessian $H = -(a_{11} + a_{22} - a_{12} - a_{21})^2$ is always negative, that is neither minimum or maximum points exist on the unit square for z_A , but for the border of the square. The same conclusion can be drawn for z_B .

In literature there are two ways to calculate the probability distribution for each player. The first way is to calculate for each player the optimal strategy on its own matrix, this one is called a prudential strategy by Straffin [?]; the second way is to calculate for each player the optimal strategy on the matrix of the other player, this one is used by Nash [?]:

- first way (prudential strategy)

$$x_p = (a_{21} - a_{22}) / (a_{12} + a_{21} - a_{11} - a_{22}) = -A_3 / A_1 \quad \text{for player } A \quad (7)$$

$$y_p = (b_{12} - b_{22}) / (b_{12} + b_{21} - b_{11} - b_{22}) = -B_2 / B_1 \quad \text{for player } B \quad (8)$$

- second way (Nash's strategy)

$$x_N = (b_{21} - b_{22}) / (b_{12} + b_{21} - b_{11} - b_{22}) = -B_3 / B_1 \quad \text{for player } A \quad (9)$$

$$y_N = (a_{12} - a_{22}) / (a_{12} + a_{21} - a_{11} - a_{22}) = -A_2 / A_1 \quad \text{for player } B \quad (10)$$

By substituting in the formulas of the expected payoffs of each player respectively the prudential strategies and the Nash's strategies it can easily be seen that the expected payoffs are equal in the two cases, thus the two couples of strategies (x_p, y_p) and (x_N, y_N) are equivalent.

Moreover combining the prudential strategies with the Nash's strategies it is found that:

$$z_A(x_p, y_N) = z_A(x_p, y_p) = z_A(x_N, y_N) \quad (11)$$

but

$$z_B(x_p, y_N) \neq z_B(x_p, y_p) = z_B(x_N, y_N) \quad (12)$$

and

$$z_B(x_N, y_p) = z_B(x_p, y_p) = z_B(x_N, y_N) \quad (13)$$

but

$$z_A(x_N, y_p) \neq z_A(x_p, y_p) = z_A(x_N, y_N) \quad (14)$$

this means that the two couples of strategies are not interchangeable.

It can be concluded that the couple of strategies does not represent a solution of the game because they are equivalent, but not interchangeable, as it is stated by Nash [?]. The non-cooperative solution does not take into account the possibility of an agreement between the two players, thus it is possible that the players choose different strategies because they are equivalent, but this is not optimal because they are not interchangeable.

The outcome of the possible choices of the two players is depicted in the following Table ??.

Table 2

	Strategies		Expected payoffs			
	x	y	z_A		z_B	
Nash	$-B_3/B_1$	$-A_2/A_1$	$A_4 - A_3$	A_2/A_1	$B_4 - B_3$	B_2/B_1
Prudential	$-A_3/A_1$	$-B_2/B_1$	$A_4 - A_3$	A_2/A_1	$B_4 - B_3$	B_2/B_1
Nash/Prud.	$-B_3/B_1$	$-B_2/B_1$	α		$B_4 - B_3$	B_2/B_1
Prud./Nash	$-A_3/A_1$	$-A_2/A_1$	$A_4 - A_3$	A_2/A_1	β	

where

$$\alpha = A_4 + (B_3 B_2 A_1 - B_3 B_1 A_2 - B_2 B_1 A_3) / B_1^2$$

$$\beta = B_4 + (A_3 A_2 B_1 - A_3 A_1 B_2 - A_2 A_1 B_3) / A_1^2$$

It comes out that in order to choose the optimal strategy the player A should look whether the value of $z_A(x_N, y_p)$ is greater or lower of $z_A(x_N, y_N)$: if it is greater then the strategy $z_A(x_N, y)$ is dominant irrespective of the choice of player B , if it is lower then the strategy $z_A(x_p, y)$ becomes dominant irrespective of the choice of player B .

The player B should look whether the value of $z_B(x_p, y_N)$ is greater or lower of $z_B(x_N, y_N)$: if it is greater then the strategy $z_B(x, y_N)$ is dominant irrespective of the choice of player A , if it is lower then the strategy $z_B(x, y_p)$ becomes dominant irrespective of the choice of player A .

It is easy to show that for A there are two cases for $z_A(x_N, y_p) > z_A(x_N, y_N)$:

1. $A_1 > 0$ and $(A_1 B_3 - A_3 B_1)(A_1 B_2 - A_2 B_1) > 0$

2. $A_1 < 0$ and $(A_1B_3 - A_3B_1)(A_1B_2 - A_2B_1) < 0$

and that also for B there are two cases for $z_B(x_p, y_N) > z_B(x_N, y_N)$:

1. $B_1 > 0$ and $(A_1B_3 - A_3B_1)(A_1B_2 - A_2B_1) > 0$
2. $B_1 < 0$ and $(A_1B_3 - A_3B_1)(A_1B_2 - A_2B_1) < 0$

Therefore a very simple rule is found because it can be easily demonstrated that:

if A_1 has the same sign of $(A_1B_3 - A_3B_1)(A_1B_2 - A_2B_1)$, then the dominant strategy for A is x_N , otherwise the dominant strategy is x_p ;

if B_1 has the same sign of $(A_1B_3 - A_3B_1)(A_1B_2 - A_2B_1)$ then the dominant strategy for B is y_N , otherwise the dominant strategy is y_p .

It should be considered for the player A the condition to have $z_A(x_N, y_p)$ equal to $z_A(x_N, y_N)$: in this case all the four strategies could be indifferent. The same situation happens for the player B if $z_B(x_p, y_N)$ is equal to $z_B(x_N, y_N)$.

It is easy to show that for A and for B there is a common condition: $(A_1B_3 - A_3B_1)(A_1B_2 - A_2B_1) = 0$ which brings to three cases:

1. $A_1B_3 - A_3B_1 = 0$ that is $x_p = -A_3/A_1 = -B_3/B_1 = x_N = x$ that is $(x, y_p) = (x, y_N)$
 therefore $z_A(x_p, y_p) = z_A(x_N, y_p) = z_A(x_N, y_N) = z_A(x_p, y_N)$
 and $z_B(x_p, y_p) = z_B(x_N, y_p) = z_B(x_N, y_N) = z_B(x_p, y_N)$;
 in this case (x_p, y_p) and (x_N, y_N) are interchangeable, this means that player B can choose between y_p or y_N but he should keep always the chosen strategy;
2. $A_1B_2 - A_2B_1 = 0$ that is $y_N = -A_2/A_1 = -B_2/B_1 = y_p = y$ that is $(x_p, y) = (x_N, y)$
 therefore $z_A(x_p, y_p) = z_A(x_N, y_p) = z_A(x_N, y_N) = z_A(x_p, y_N)$
 and $z_B(x_p, y_p) = z_B(x_N, y_p) = z_B(x_N, y_N) = z_B(x_p, y_N)$;
 in this case (x_p, y_p) and (x_N, y_N) are interchangeable, this means that player A can choose between x_p or x_N but he should keep always the chosen strategy;
3. both conditions are simultaneously verified
 that is $x_p = x_N$ and $y_N = y_p$ that is $(x_p, y_p) = (x_N, y_N) = (x_p, y_N) = (x_N, y_p)$
 therefore $z_A(x_p, y_p) = z_A(x_N, y_p) = z_A(x_N, y_N) = z_A(x_p, y_N)$
 and $z_B(x_p, y_p) = z_B(x_N, y_p) = z_B(x_N, y_N) = z_B(x_p, y_N)$;
 in this case there is only one distribution (x, y) .

In all the last three cases there is only one expected payoff both for A and for B .

2.2 Remarks about the classical solution

The prudential strategy is calculated for each player on the basis of its own matrix of the payoffs, but the expected payoff for each player is based also on the knowledge of the prudential strategy of the other player and the last one is based on the matrix of the payoffs of the other player. Something similar happens for the Nash's way because the strategy of each player is based on the matrix of the payoffs of the other player, so the expected payoff of a player is depending upon the matrix of the payoffs of the other. In both cases there is a possible flaw of the method because also if a player should be able to state precisely his payoffs matrix corresponding to each of his own strategies, he could not be able to state precisely the payoffs matrix of the competitor.

3 Numerical solutions of some games in normal form

3.1 Example 1

As a first example a game published and solved by Nash [?] is shown in Table ??.

Table 3

		Moves of player B	
		y	$1 - y$
Moves of player A	x	5, -3	-4, 4
	$1 - x$	-5, 5	3, -4

The expected payoffs are

$$z_A = 17xy - 7x - 8y + 3 \quad (15)$$

$$z_B = -16xy + 8x + 9y - 4 \quad (16)$$

The strategies are following:

- first way (prudential strategy)

$$x_p = 8/17 \quad \text{for player A} \quad (17)$$

$$y_p = 1/2 \quad \text{for player B} \quad (18)$$

with $z_A(x_p, y_p) = -0,2941$ and $z_B(x_p, y_p) = 0,5$

- second way (Nash's strategy)

$$x_N = 9/16 \quad \text{for player A} \quad (19)$$

$$y_N = 7/17 \quad \text{for player B} \quad (20)$$

with $z_A(x_N, y_N) = -0,2941$ and $z_B(x_N, y_N) = 0,5$

For A it comes out that

$(A_1B_3 - A_3B_1)(A_1B_2 - A_2B_1) = (17 \times 9 - 16 \times 8) \times (17 \times 8 - 16 \times 7) = 25 \times 24 > 0$ and $A_1 = 17 > 0$
this means that

$z_A(x_N, y_p) = -0,15625 > z_A(x_p, y_N) = z_A(x_p, y_p) = z_A(x_N, y_N) = -0,2941$ thus x_N is the dominant strategy for A.

For B it comes out that $(A_1B_3 - A_3B_1)(A_1B_2 - A_2B_1) = (17 \times 9 - 16 \times 8) \times (17 \times 8 - 16 \times 7) = 25 \times 24 > 0$ and $B_1 = -16 < 0$

this means that

$z_B(x_p, y_N) = 0,3702 < z_B(x_N, y_p) = z_B(x_p, y_p) = 0,5$ thus y_p is the dominant strategy for B.

Thus the solution of the game is $(x_N, y_p) = (-B_3/B_1, -B_2/B_1)$ that is $(9/16, 7/16)$ for A & $(1/2, 1/2)$ for B with $z_A(x_N, y_p) = -0,15625$ and $z_B(x_N, y_p) = 0,5$.

3.2 Example 2

As a second example a game from the relevant literature is shown in Table ??.

Analogously to the above developed Example 1 the solution of the game is found to be $(x_N, y_p) = (-B_3/B_1, -B_2/B_1)$ that is $(12/17, 5/17)$ for A & $(10/17, 7/17)$ for B with $z_A(x_N, y_p) = 3,197$ and $z_B(x_N, y_p) = 2,4117$.

Table 4

		Moves of player <i>B</i>	
		<i>y</i>	$1 - y$
Moves of player <i>A</i>	<i>x</i>	5,2	1,3
	$1 - x$	2,17/5	4,1

3.3 Example 3

As a third example a game from the relevant literature is shown in Table ??.

Table 5

		Moves of player <i>B</i>	
		<i>y</i>	$1 - y$
Moves of player <i>A</i>	<i>x</i>	1,5	3,1
	$1 - x$	2,3	2,4

Analogously to the above developed Example 1 the solution of the game is found to be $(x_p, y_N) = (-A_3/A_1, -A_2/A_1)$ that is $(0, 1)$ for *A* & $(1/2, 1/2)$ for *B* with $z_A(x_p, y_N) = 2$ and $z_B(x_p, y_N) = 3, 5$.

4 Geometric solution of the normal form

4.1 Theory

The formula of the expected payoff for each player can be modified as follows:

$$(a_{11} + a_{22} - a_{12} - a_{21})xy + (a_{12} - a_{22})x + (a_{21} - a_{22})y + a_{22} - z_A = 2A_{12}xy + 2A_{14}x + 2A_{24}y + 2A_{43}z_A + A_{44} = 0 \quad (21)$$

and analogously

$$(b_{11} + b_{22} - b_{12} - b_{21})xy + (b_{12} - b_{22})x + (b_{21} - b_{22})y + b_{22} - z_B = 2B_{12}xy + 2B_{14}x + 2B_{24}y + 2B_{43}z_B + B_{44} = 0 \quad (22)$$

then it is easy to recognize that it is a bi-linear quadratic form which in the space x, y, z represents a hyperbolic paraboloid that is a “saddle paraboloid” [10]. In fact the determinant of the complete matrix *A*, being A_{ij} its terms, is

$$\det(A) = (A_{12})^2(A_{43})^2 = 1/4(a_{11} + a_{22} - a_{12} - a_{21})^2(1/2)^2 = 1/16(a_{11} + a_{22} - a_{12} - a_{21})^2 \quad (23)$$

In order to have the mixed strategies it should hold

$$(a_{11} + a_{22} - a_{12} - a_{21}) \neq 0 \quad (24)$$

therefore it is always

$$\det(A) = 1/16(a_{11} + a_{22} - a_{12} - a_{21})^2 > 0 \quad (25)$$

This means that the quadric has hyperbolic points. Moreover the determinant of the first minor of the matrix, the three first rows and the three first columns, is equal to zero and its ranking is 2, so it can be concluded that the quadric represented by the expected payoff is a hyperbolic paraboloid. The same conclusion holds for the expected payoff of player B . Since now on the two quadrics will be named Q_A and Q_B .

In order to look for the maximum and minimum points of Q_A on the square $0 < x < 1$ e $0 < y < 1$, the Hessian is calculated [12]. As a first finding the first derivative of the form gives:

$$\partial z_A / \partial x = 0 \quad (26)$$

implies

$$y = (a_{12} - a_{22}) / (a_{12} + a_{21} - a_{11} - a_{22}) = -A_{14} / A_{12} = -A_2 / A_1 = y_N \quad (27)$$

that is the probability distribution for player B after Nash and

$$\partial z_A / \partial y = 0 \quad (28)$$

implies

$$x = (a_{21} - a_{22}) / (a_{12} + a_{21} - a_{11} - a_{22}) = -A_{24} / A_{12} = -A_3 / A_1 = x_p \quad (29)$$

that is the prudential probability distribution for player A .

The meaning is that if player B chooses y_N then there is no variation of z_A irrespective of the choice of player A ; if player A chooses x_p there is no variation of z_A irrespective of the choice of player B .

The second finding is that the same conclusion as per the algebraic classical solution can be drawn: the Hessian is always negative, that is neither minimum nor maximum points exist on the unit square for Q_A , as it could be expected due to the properties of the hyperbolic paraboloid [?].

Analogously looking for the maximum and minimum points of Q_B on the square $0 < x < 1$ e $0 < y < 1$, the Hessian is calculated. As a first finding the first derivative of the form gives:

$$\partial z_B / \partial x = 0 \quad (30)$$

implies

$$y = (b_{12} - b_{22}) / (b_{12} + b_{21} - b_{11} - b_{22}) = -B_{14} / B_{12} = -B_2 / B_1 = y_p \quad (31)$$

that is the prudential probability distribution for player B and

$$\partial z_B / \partial y = 0 \quad (32)$$

implies

$$x = (b_{21} - b_{22}) / (b_{12} + b_{21} - b_{11} - b_{22}) = -B_{24} / B_{12} = -B_3 / B_1 = x_N \quad (33)$$

that is the probability distribution for player A after Nash.

The meaning is that if player B chooses y_p then there is no variation of z_B irrespective of the choice of player A ; if player A chooses x_N there is no variation of z_B irrespective of the choice of player B .

As above found for Q_A also for Q_B , if the condition of existence of the mixed strategies is verified, the Hessian:

$$H = -(b_{11} + b_{22} - b_{12} - b_{21})^2$$

is always negative, that is neither minimum nor maximum points exist on the unit square for Q_B .

The discussion of the first derivatives of the expected payoffs, the two quadrics Q_A and Q_B , gives a rationale of the two different ways to calculate the probability distribution on the strategies:

- the prudential strategy

$$\partial z_A / \partial y = 0 \text{ implies } x = x_p = -A_3/A_1 \quad (34)$$

$$\partial z_B / \partial x = 0 \text{ implies } y = y_p = -B_3/B_1 \quad (35)$$

guarantees that each player receives a payoff irrespective of the choice of the other player; this explains why:

$$z_A(x_p, y_N) = z_A(x_p, y_p) = z_A(x_p, y) \quad (36)$$

$$z_B(x_N, y_p) = z_B(x_p, y_p) = z_B(x, y_p) \quad (37)$$

- the Nash's strategy

$$\partial z_B / \partial y = 0 \text{ implies } x = x_N = -B_3/B_1 \quad (38)$$

$$\partial z_A / \partial x = 0 \text{ implies } y = y_N = -A_2/A_1 \quad (39)$$

guarantees that each player receives a payoff irrespective of his own choice; this explains why:

$$z_A(x_p, y_N) = z_A(x_N, y_N) \quad (40)$$

$$z_B(x_N, y_p) = z_B(x_N, y_N) \quad (41)$$

By solving the secular equation for every quadric the principal planes are found:

- Q_A

$$x + y + (A_{14} + A_{24})/(A_{12}) = x + y + (A_2 + A_3)/A_1 = 0 \quad (42)$$

$$-x + y + (A_{14} - A_{24})/(A_{12}) = -x + y + (A_2 - A_3)/A_1 = 0 \quad (43)$$

- Q_B

$$x + y + (B_{14} + B_{24})/(B_{12}) = x + y + (B_2 + B_3)/B_1 = 0 \quad (44)$$

$$-x + y + (B_{14} - B_{24})/(B_{12}) = -x + y + (B_2 - B_3)/B_1 = 0 \quad (45)$$

The two principal planes for every quadric are orthogonal and their traces on the plane $z = 0$ are parallel to the bisector of the first and third quadrant and to the bisector of the second and fourth quadrant; moreover the principal planes of a quadric are parallel to the principal planes of the other quadric.

The transversal principal plane generates a cross section that is a downward open parabola; the longitudinal principal plane generates a cross section that is an upward open parabola.

The intersection line of the principal planes is:

- Q_A

$$x_{A0} = -A_{24}/A_{12} = -A_3/A_1 = x_p \quad (46)$$

$$y_{A0} = -A_{14}/A_{12} = -A_2/A_1 = y_N \quad (47)$$

- Q_B

$$x_{B0} = -B_{24}/B_{12} = -B_3/B_1 = x_N \quad (48)$$

$$y_{B0} = -B_{14}/B_{12} = -B_2/B_1 = y_p \quad (49)$$

and the corresponding values of the quadrics are:

$$z_{A0}(x_{A0}, y_{A0}) = A_{44} - 2A_{24}A_{14}/A_{12} = A_4 - A_3A_2/A_1 =$$

$$z_A(x_p, y_N) = z_A(x_p, y_p) = z_A(x_N, y_N) \quad (50)$$

$$z_{B0}(x_{B0}, y_{B0}) = B_{44} - 2B_{24}B_{14}/B_{12} = B_4 - B_3B_2/B_1 =$$

$$z_B(x_N, y_p) = z_B(x_p, y_p) = z_B(x_N, y_N) \quad (51)$$

The two points (x_{A0}, y_{A0}, z_{A0}) and (x_{B0}, y_{B0}, z_{B0}) are the vertices, saddle points, of the two quadrics, moreover the relationships with the expected payoffs are holding.

From a geometric point of view the points (x_{A0}, y_{A0}, z_{A0}) and (x_p, y_p, z_{A0}) and the points (x_{A0}, y_{A0}, z_{A0}) and (x_N, y_N, z_{A0}) are aligned and they belong to two orthogonal lines: they belongs to the quadric and they belong to the same plane $z = z_{A0}$ which is tangent to the paraboloid; in fact the paraboloid is hyperbolic and each plane tangent to it has two lines belonging to the paraboloid. The same remark holds for the other quadric Q_B .

The plane tangent in the vertex divides the space in the points which are above the vertex and the points which are below the vertex.

It has to be pointed out that:

$$z_{A0}(x_{A0}, y_{A0}) \neq z_A(x_N, y_p) \quad (52)$$

$$z_{B0}(x_{B0}, y_{B0}) \neq z_B(x_p, y_N) \quad (53)$$

This is a confirmation that the two solutions (x_p, y_p) and (x_N, y_N) are generally not interchangeable. It easy to see that the intersections between each quadric and the plane tangent to the quadric in the vertex are two orthogonal lines:

- Q_A

$$x = -A_{24}/(A_{12}) = -A_3/A_1 = x_p \quad (54)$$

$$y = -A_{14}/(A_{12}) = -A_2/A_1 = y_N \quad (55)$$

with $z = z_{A0}$

- Q_B

$$x = -B_{24}/(B_{12}) = -B_3/B_1 = x_N \quad (56)$$

$$y = -B_{14}/(B_{12}) = -B_2/B_1 = y_p \quad (57)$$

with $z = z_{B0}$

Moreover the two tangent lines to a quadric are parallel to the two tangent lines to the other quadric. The following figure is depicting this relationship between the two quadrics: the orthogonal lines are the intersections with the plane $z = 0$ of the vertical planes containing the orthogonal tangent lines to the quadrics.

It has to be noted that the two tangents to a quadric in the vertex are lying on a plane parallel to the plane xOy . Anyway the crossing point of the tangents of Q_A has a z_{A0} coordinate different from the z_{B0} of Q_B ; this means that the expected payoff of player A with (x_N, y_p) could be greater

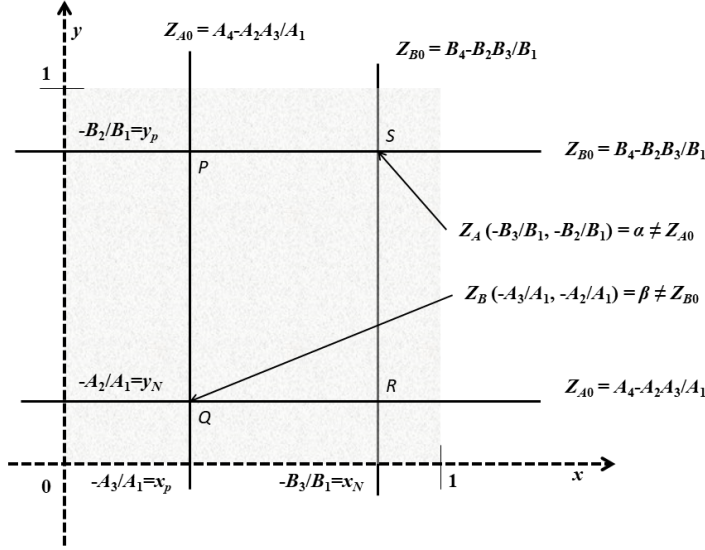

Figure 1

or lower than z_{A0} with (x_N, y_N) and for player B with (x_p, y_N) could be greater or lower than z_{B0} with (x_N, y_N) .

Generally speaking the four points P , Q , R and S can be reached with couples of strategies, but whereas P and R are equivalent and not interchangeable, Q and S are nor equivalent nor interchangeable; it is worth to note that Q is the vertex of Q_A and S is the vertex of Q_B . Nevertheless after the conditions above discussed, it could happen that the points Q and P are coinciding with R and S , the points S and P are coinciding with R and Q and all the four points can coincide.

4.2 Remarks about the geometric solution

The geometric way gives a rationale of the two different ways to calculate the probability distribution on the strategies. The prudential strategy is a choice of each player giving an expected payoff independent from the choice of the other; it is obtained by nullifying the derivative of his own expected payoff and is based on his own payoff matrix. The Nash's strategy is the best response to the strategy of the other player; it is obtained by nullifying the derivative of the other player expected payoff based on the assumption that the other player will not change his choice. Nevertheless the two ways give the same value of the expected payoffs, therefore they are equivalent.

These strategies are not generally interchangeable, nevertheless the expected payoffs of the cross combined strategies could be better than each of the two strategies and applying the dominance principle the optimal solution is found.

The geometric solution way is working also if the probability distribution on the strategies cannot be obtained in the classical algebraic way. From this point of view the geometric solution is a very powerful tool to solve non-cooperative two by two games and to understand the meaning of the different probability distributions.

5 Geometric solutions of some games in normal form

5.1 Example 1

The geometric solution is applied to the first example published and solved by Nash [?]. With reference to formulas ?? and ??, by calculating the first derivatives of the two quadrics, Q_A and Q_B , the probability distribution on the strategies is obtained:

- prudential strategy (formulas ?? and ??)

$$x_p = 8/17$$

$$y_p = 1/2$$

- Nash's strategy (formulas ?? and ??)

$$x_N = 9/16$$

$$y_N = 7/17$$

The principal planes are:

- Q_A

$$\text{Transversal (formula ??): } x + y - 15/17 = 0$$

$$\text{Longitudinal (formula ??): } -x + y + 1/17 = 0$$

- Q_B

$$\text{Longitudinal (formula ??): } x + y + 17/16 = 0$$

$$\text{Transversal (formula ??): } -x + y - 1/16 = 0$$

As it can be seen in Figure ?? for Q_A the longitudinal principal plane is bisecting the first and third quadrant and the transversal principal plane is bisecting the second and fourth quadrant; for Q_B the transversal principal plane is bisecting the first and third quadrant and the longitudinal principal plane is bisecting the second and fourth quadrant.

It is interesting to note that Q_A and Q_B are "orthogonal": the longitudinal plane of Q_A is parallel to the transversal plane of Q_B .

The intersection line of the principal planes is:

- Q_A (formulas ?? and ??)

$$x_{A0} = 8/17 = x_p$$

$$y_{A0} = 7/17 = y_N$$

- Q_B (formulas ?? and ??)

$$x_{B0} = 9/16 = x_N$$

$$y_{B0} = 1/2 = y_p$$

and the corresponding values of the quadrics are:

Q_A (formula ??)

$$z_{A0}(x_{A0}, y_{A0}) = z_A(x_p, y_N) = z_A(x_p, y_p) = z_A(x_N, y_N) = -5/17$$

Q_B (formula ??)

$$z_{B0}(x_{B0}, y_{B0}) = z_B(x_N, y_p) = z_B(x_p, y_p) = z_B(x_N, y_N) = 1/2$$

The intersections between each quadric and the plane tangent to the quadric in the vertex are two orthogonal lines:

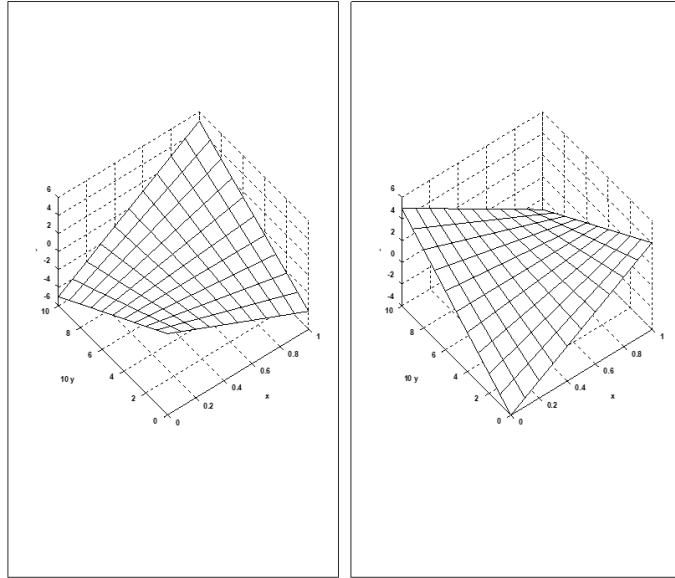

Figure 2

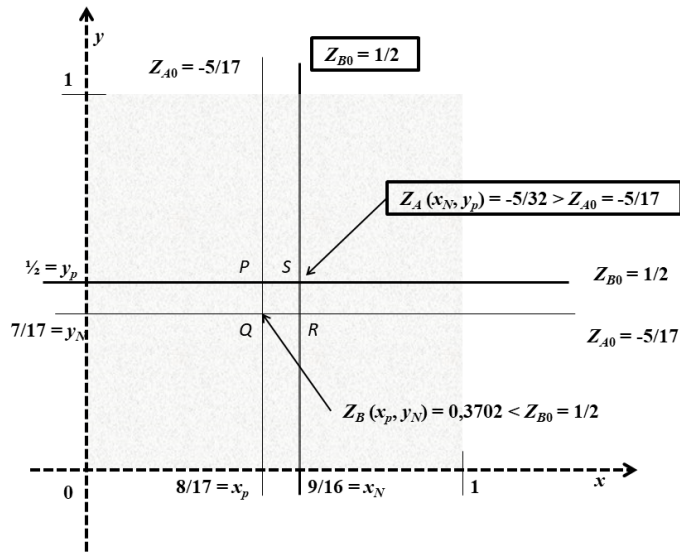

Figure 3

- Q_A (formulas ?? and ??)
 $x = x_p = 8/17$
 $y = y_N = 7/17$
 with $z = z_{A0} = -5/17$

- Q_B (formulas ?? and ??)
 $x = x_N = 9/16$
 $y = y_p = 1/2$
with $z = z_{B0} = 1/2$

Figure ?? is depicting the relationship between the two quadrics: the orthogonal lines are the intersections with the plane $z = 0$ of the vertical planes containing the orthogonal tangent lines to the quadrics.

The thick lines are the dominant strategies and represent the solution of the game with the expected payoffs given by point S . Thus, as already found in the analytical way, the solution of the game is $(x_N, y_p) = (-B_3/B_1, -B_2/B_1)$ that is $(9/16, 7/16)$ for A & $(1/2, 1/2)$ for B with $z_A(x_N, y_p) = -0,15625$ and $z_B(x_N, y_p) = 0,5$.

5.2 Example 2

Analogously to Example 1, the geometric solution is searched for the second example taken from the relevant literature.

As it can be seen in Figure ?? for Q_A the longitudinal principal plane is bisecting the first and third quadrant and the transversal principal plane is bisecting the second and fourth quadrant; for Q_B the transversal principal plane is bisecting the first and third quadrant and the longitudinal principal plane is bisecting the second and fourth quadrant.

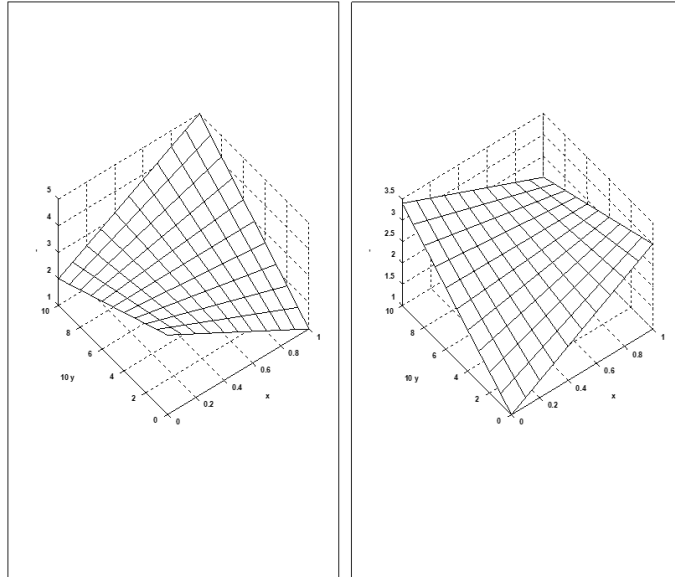

Figure 4

Also for this game it is interesting to note that Q_A and Q_B are “orthogonal”: the longitudinal plane of Q_A is parallel to the transversal plane of Q_B .

Figure ?? is depicting the relationship between the two quadrics: the orthogonal lines are the intersections with the plane $z = 0$ of the vertical planes containing the orthogonal tangent lines to the quadrics.

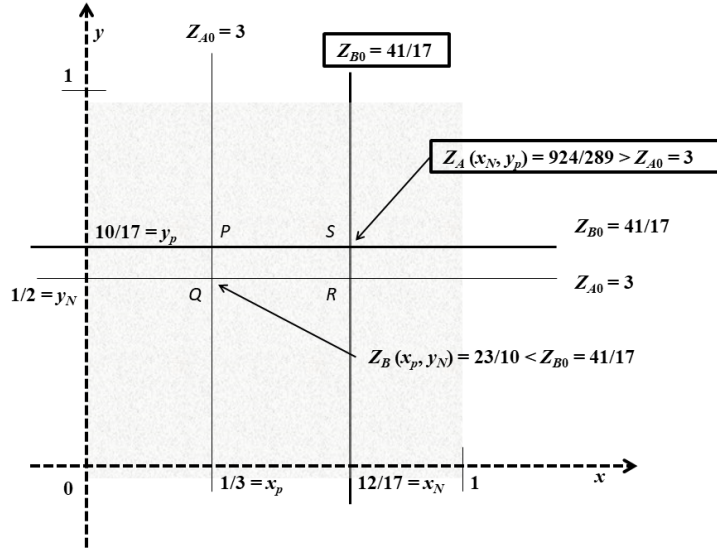

Figure 5

The thick lines are the dominant strategies and represent the solution of the game with the expected payoffs given by point S . Thus, as already found in the analytical way, the solution of the game is $(x_N, y_p) = (-B_3/B_1, -B_2/B_1)$ that is $(12/17, 5/17)$ for A & $(10/17, 7/17)$ for B with $z_A(x_N, y_p) = 3, 197$ and $z_B(x_N, y_p) = 2, 4117$.

5.3 Example 3

Analogously to Example 1, the geometric solution is searched for the third example taken from the relevant literature.

As it can be seen in Figure ?? for Q_A the longitudinal principal plane is bisecting the first and third quadrant and the transversal principal plane is bisecting the second and fourth quadrant; for Q_B the transversal principal plane is bisecting the first and third quadrant and the longitudinal principal plane is bisecting the second and fourth quadrant.

Also for this game note that Q_A and Q_B are “orthogonal”: the longitudinal plane of Q_A is parallel to the transversal plane of Q_B . Figure ?? is depicting the relationship between the two quadrics: the orthogonal lines are the intersections with the plane $z = 0$ of the vertical planes containing the orthogonal tangent lines to the quadrics.

The thick lines are the dominant strategies and represent the solution of the game with the expected payoffs given by point S . Thus, as already found in the analytical way, the solution of the game is $(x_p, y_N) = (-A_3/A_1, -A_2/A_1)$ that is $(0, 1)$ for A & $(1/2, 1/2)$ for B with $z_A(x_p, y_N) = 2$ and $z_B(x_p, y_N) = 7/2$.

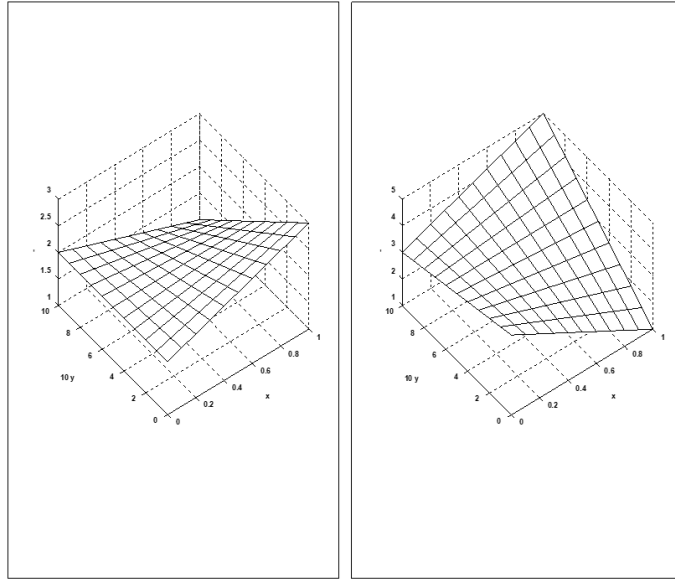

Figure 6

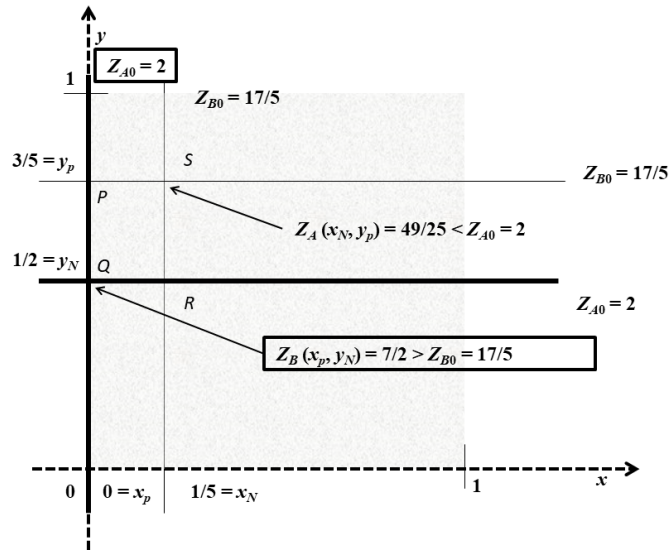

Figure 7

5.4 Example 4

A very interesting fourth example taken from the relevant literature is shown here below.

As it can be seen in Figure ?? for Q_A the transversal principal plane is bisecting the first and third quadrant and the longitudinal principal plane is bisecting the second and fourth quadrant; for

Table 6

		Moves of player <i>B</i>	
		<i>y</i>	$1 - y$
Moves of player <i>A</i>	<i>x</i>	6,6	2,7
	$1 - x$	7,2	0,0

Q_B the transversal principal plane is bisecting the first and third quadrant and the longitudinal principal plane is bisecting the second and fourth quadrant.

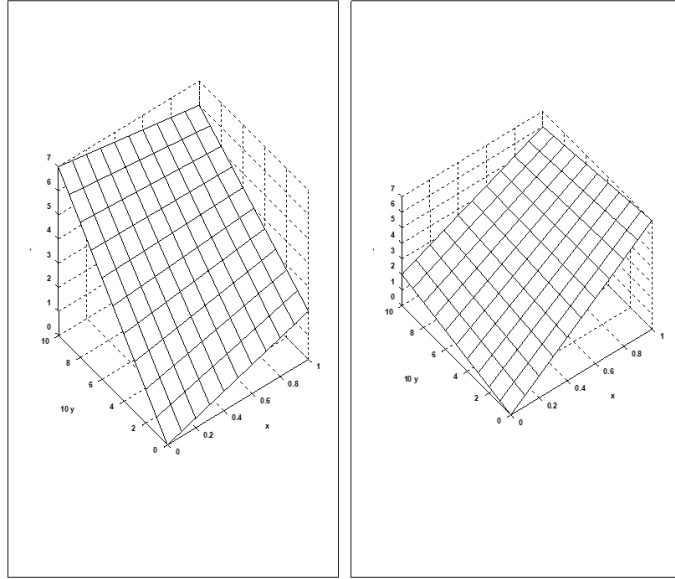

Figure 8

In this case it is interesting to note that Q_A and Q_B are “parallel”: the longitudinal plane of Q_A and Q_B is the same.

Figure ?? is depicting the relationship between the two quadrics: the orthogonal lines are the intersections with the plane $z = 0$ of the vertical planes containing the orthogonal tangent lines to the quadrics.

The thick lines are the dominant strategies and represent the solution of the game with the expected payoffs given by point Q . Thus, the solution of the game is $(x_N, y_N) = (-B_3/B_1, -A_2/A_1)$ that is $(2/3, 1/3)$ for A & $(2/3, 1/3)$ for B with $z_A(x_N, y_N) = 14/3$ and $z_B(x_N, y_N) = 14/3$.

The algebraic solution gives all the four points P, Q, R and S , but the geometric solution shows that the only acceptable solution is point $Q \equiv (x_N, y_N)$, inside the unit square.

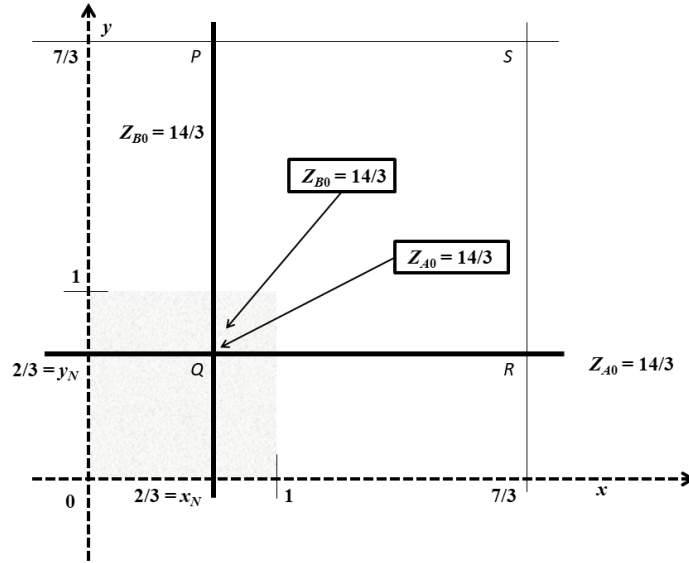

Figure 9

6 Conclusions

The proposed non-cooperative solution of the two by two games is based on the application of the dominance principle, therefore the paper is dealing only with two by two game with no dominances on the pure strategies and the dominance principle is applied to find the solution on the mixed strategies too.

The main conclusions holding independently from the specific values of the payoff matrix are following:

- A) Given the existence conditions of the mixed strategies, x and y taking non negative finite values and not greater than one, the expected payoff of each player takes the form of a hyperbolic paraboloid having the principal planes parallel to the bisecting planes of the first and third octant and of the second and forth octant;
- B) The principal planes of the expected paraboloid-shaped payoffs of the two players are parallel;
- C) The value of the expected payoff either for prudential or Nash distribution is equal to the value of the vertex of the paraboloid;
- D) The value of the expected payoff corresponding to the prudential distribution for a player is not only independent either from the prudential or the Nash's distribution of the other player, but it is independent from every distribution of the other player; moreover when a player chooses the Nash's distribution the expected payoff of the other player is not depending upon his own strategy distribution;
- E) From a geometric point of view the rationale of points C) and D) is that the expected payoff corresponding to prudential and Nash strategies belongs to the plane tangent to the paraboloid in the vertex;

- F) The two orthogonal lines belonging to the tangent plane in the vertex of each paraboloid are lying on a horizontal plane at the level of the value of the expected payoff either for the prudential and Nash strategies for each player; moreover the vertical planes containing these two lines are intersecting the other paraboloid along two lines whose crossing point is corresponding to the mixed prudential and Nash strategies and the crossing point is unique;
- G) Generally speaking the couples of prudential and Nash's strategies are not interchangeable, but by applying the dominance principle it is possible to choose the right equilibrium strategies avoiding the bad consequences due to the non-interchangeability of the strategies;
- H) From point F) it comes out that the projection of these four lines on the plane xOy appears as four orthogonal lines intersecting in four points which represent the four possible combinations of the prudential and Nash's probability distributions as depicted in Table ??;
- I) It is worth noting that in the case of zero sum game these four lines are superposed on two orthogonal lines intersecting in one point which is the unique mixed strategies solution of the game; as it can easily be understood the zero sum game is a special case of the general sum games;
- J) On the basis of the dominance principle the dominant mixed strategy is given by the point that has the greatest expected payoff: on the basis of point F) the so found equilibrium pair is candidate to be a perfect equilibrium pair [?].

Here below some conclusions depending upon the specific values of the payoff matrices are given.

- A) In some cases the principal longitudinal plane of a quadric is orthogonal to the longitudinal plane of the other one; in other cases the two planes are parallel.
- B) A conjecture of the geometric way of solution is that the so found solution is unique (Nash [?]). In this case the so found equilibrium pair of the non-cooperative solution gives the maximin value of the game for each player from which the cooperative solution of the game can be found too [?].

Interest Conflicts

The author declares that there is no conflict of interest concerning the publishing of this paper.

Funding Statement

No funding was received for conducting this study.

Acknowledgments

The author wishes to thank Prof. Rosalba Ferrari, University of Bergamo Department of Engineering and Applied Sciences, for her invaluable help during the editorial preparation of the paper.

References

- [1] Nash J.F. (1951) *Non-Cooperative Games*. Annals of Mathematics, Second Series 54(2), 286–295, Mathematics Department, Princeton University.

- [2] Nash J.F. (1950) *The bargaining problem*. *Econometrica*, 18(2), 155–162.
- [3] Nash J.F. (1950) *Equilibrium points in n -person games*. *Proceedings of the National Academy of Sciences of the United States of America*, 36(1), 48–49.
- [4] Nash J.F. (1953) *Two-person cooperative games*. *Econometrica*, 21(1), 128–140.
- [5] Luce R.D., Raiffa H. (1957) *Games and decisions: Introduction and critical survey*. Dover books on Advanced Mathematics, Dover Publications.
- [6] Owen G. (1968) *Game theory*. New York: Academic Press (I ed.), New York: Academic Press (II ed. 1982), San Diego (III ed. 1995), United Kingdom: Emerald (IV ed. 2013)
- [7] Straffin P.D. (1993) *Game Theory and Strategy*. The Mathematical Association of America, New Mathematical Library.
- [8] Van Damme E. (1991) *Stability and Perfection of Nash Equilibria*. Springer-Verlag. Second, Revised and Enlarged Edition.
- [9] Dixit A.K., Skeath S. (2004) *Games of Strategy*. Norton & Company. Second Edition.
- [10] Tognetti M. (1970) *Geometria*. Pisa, Italy: Editrice Tecnico Scientifica.
- [11] Maschler M., Solan E., Zamir S. (2017) *Game theory*. UK: Cambridge University Press.
- [12] Esposito G., Dell’Aglia L. (2019) *Le Lezioni sulla teoria delle superficie nell’opera di Ricci-Curbastro*. Unione Matematica Italiana.
- [13] Bertini C., Gambarelli G., Stach I. (2019) *Strategie – Introduzione alla Teoria dei Giochi e delle Decisioni*. G. Giappichelli Editore.
- [14] Vygotskij M.J. (1975) *Mathematical Handbook Higher Mathematics*. MIR, Moscow.
- [15] Von Neumann J., Morgenstern O. (1944) *Theory of Games and Economic Behavior*. New Jersey Princeton University Press.