



Munich Personal RePEc Archive

Scenarios of economic development in Romania - medium to long-term forecasting models

Albu, Lucian-Liviu and Roudoi, Andrei

December 2003

Online at <https://mpra.ub.uni-muenchen.de/13588/>
MPRA Paper No. 13588, posted 23 Feb 2009 14:12 UTC

Scenarios of Economic Development in Romania - Medium to Long-Term Forecasting Models

Lucian-Liviu Albu
(Institute for Economic Forecasting)

Andrei Roudoi
(Global Insight)

Abstract

In order to obtain plausible scenarios of economic development in Romania up to the 2015 horizon, we used a mix of forecasting models, from ones classified as “medium-term” to those covering longer forecasting periods. Based on the analysis of the economic transition period we mainly used three models: a) A sustainability function model (public debt and fiscal deficits); b) A simple econometric model, based on a production function, in which FDI and exports are introduced as inputs in addition to labour and domestic capital (also developed as a quarterly model); c) A standard Cobb-Douglas model (also used in the case of the main economic sectors). In this paper we are synthetically presenting the basic equations of the models, and also their main simulation outputs.

Keywords: forecasting, sustainability function, production function, economic growth
JEL classification: C53, E23, E25, O4

Note: This paper was prepared for the international workshop within the program “Improvement of Economic Policy through Think Tank Partnership”, held in Bucharest, Romania, on October 27-29, 2003, and is part of a grant by the U.S. Agency for International Development for the project “Mechanisms of Long-term Growth in the Economies in Transition (Cases of Russia and Romania)”. The research partners of this project are Global Insight (former DRI-WEFA – USA), the Institute of Economic Forecasting (Romania) and the Center for Macroeconomic Analysis and Short-term Economic Forecasting (Russian Federation). The opinions, findings and conclusions or recommendations expressed herein are those of the authors and do not necessarily reflect the views of the U.S. Agency for International Development.

Scenarios of Economic Development in Romania - Medium to Long-Term Forecasting Models*

Lucian-Liviu ALBU**

Andrei ROUDOI***

In order to obtain plausible scenarios of economic development in Romania up to the 2010-2015 horizon, we used a mix of forecasting models, from ones classified as “medium-term” to those covering longer forecasting periods.

Based on the analysis of the economic transition period we mainly used three models:

- A sustainability function model (public debt and fiscal deficits).
- A simple econometric model, based on a production function, in which FDI and exports are introduced as inputs in addition to labour and domestic capital (also developed as a quarterly model).
- A standard Cobb-Douglas model (also used in the case of the main economic sectors).

In this paper we are synthetically presenting the basic equations of the models, and also their main simulation outputs.

The Sustainability Function

To quantify **dynamics of public debt on short-term** we used the following equation:

$$D_t - D_{t-1} = i_t D_{t-1} + \Pi_t + re_t D_{t-1} - \Delta M_t \quad (1)$$

* This paper was prepared for the international workshop within the program “Improvement of Economic Policy through Think Tank Partnership”, held in Bucharest, Romania, on October 27-29, 2003, and is part of a grant by the U.S. Agency for International Development for the project “Mechanisms of Long-term Growth in the Economies in Transition (Cases of Russia and Romania)”. The research partners of this project are Global Insight (former DRI-WEFA – USA), the Institute of Economic Forecasting (Romania) and the Center for Macroeconomic Analysis and Short-term Economic Forecasting (Russian Federation). The opinions, findings and conclusions or recommendations expressed herein are those of the authors and do not necessarily reflect the views of the U.S. Agency for International Development.

** Research Professor and Director at the Institute for Economic Forecasting, Romanian Academy.

*** Director of Research Department at Global Insight, Washington, D.C.

where D is public debt; i - average nominal interest rate on public sector debt; Π - primary deficit (net of interest payments); re - revaluation effect on existing debt; and ΔM - direct financing of budget from the Central Bank.

Dividing both sides of equation (1) by nominal GDP, Y_t , and manipulating we obtain:

$$d_t - d_{t-1} = (i_t + re_t - g_t) [d_{t-1} / (1 + g_t)] + \pi_t - m_t \quad (2)$$

where g is nominal GDP growth rate and $m = \Delta M/Y$.

Alternatively, we can approximate the nominal growth rate g as the sum of the change in GDP deflator p and the real GDP growth rate q , and rewrite equation (2) as follows:

$$d_t - d_{t-1} = (is_t - q_t) [d_{t-1} / (1 + g_t)] + \pi_t - m_t \quad (3)$$

where "is" means a composite interest rate (it is equal to the average real interest rate on public sector debt, $i - p$, plus the revaluation effect, re).

Dynamics of debt in the long run

The most important result for our study is the function $f(\pi, m, is, q, p, d)$, obtained by dividing equation (3) by d_{t-1} . It must tend to zero in dynamics (or at least to a very small constant value), as a fundamental condition for sustainability:

$$f1((\pi, m, is, q, p, d) = [(\pi - m) / d] + (is - q) / (1 + p + q) \quad (4)$$

or

$$f2((\pi, m, is, q, p, d) = [(\pi - m) / d] + (is - q) / (1 + p + q + pq) \quad (4')$$

There are certain features of the sustainability function, as follows:

- Its first term means the impact of direct governmental policies (budgetary policies) and those of the central monetary authorities (monetary policies), respectively.
- The second term, expressed by the ratio $(is-q)/(1+p+q)$, or more precisely by $(is-q)/(1+p+q+pq)$, describes the behaviour of the real economy.
- In order to study the behaviour of the real economy, we used two partial models, destined to simulate the following correlations: investment rate-growth rate and investment rate-investment efficiency respectively. The main hypotheses on which the models are based are referring to the existence of a direct positive correlation either between investment rate (α) and GDP growth rate (q) or between investment rate and its efficiency (η):

$$qT_t = a \alpha_{t-1} + b \quad (5)$$

$$\eta T_t = c \alpha_{t-1} + is_{t-1} \quad (6)$$

$$\eta_t = \Delta Yd / I_{t-1} = (Yd_t - Yd_{t-1}) / I_{t-1} \quad (6')$$

where a, b, c are coefficients estimated for the period 1993-2001; Yd - disposable income of private sector and households after the extraction of all taxes, T_x ($Yd = Y - T_x$); I - investments; and $qT, \eta T$ - theoretical levels.

- At limit, in the case of an investment efficiency that equals the interest rate (is), the investment process is stopped, i.e. $\alpha = 0$ (in this limit-case, the economic agents will be stimulated to place their savings in banks, the economic investments as an alternative of investing their own capital or savings giving them no supplementary money return).

- As we can see from the definition relations of the sustainability function (relations (5) and (6)), what is most interesting from the sustainability viewpoint on the real economy side is the difference in the numerator of the second term of the general sustainability function, i.e. the difference is $-q$ (as it was already shown, on the budgetary-monetary side of the economy the interest focuses on the dynamics of the difference $\pi - m$).
- In order to study the sustainability behaviour on the real side of economy, we combined the two partial models. After some algebraic operations and using the so-called backward perfect foresight technique, we can explicitly write the general function of the interest rate, R , as follows:

$$R(q, tx, \Delta tx) = [qa^2(1-tx+\Delta tx)+\Delta txa^2] / [-Kq^2 + K(a+2b)q - ab - Kb^2] \quad (7)$$

where

$$K = (kE - 1) a / (qE - b), \quad tx = Tx / Y, \quad \text{and} \quad Y = Yd + Tx$$

and qE is the GDP growth rate corresponding to the saving rate (as according to the first partial model); kE - the ratio of the efficiency corresponding to the level of brute savings and the interest rate (as according to the second partial model); tx - general rate of taxation; and Δtx - annual change of tx (in percentage points).

- In the context of sustainability function we are also interested in function of the difference function $G=R-q$. Considering, by simplification reasons, $\Delta tx = 0$ and $qE = q$, we obtained the following expression for function G :

$$G(q, kE, tx) := \frac{q \cdot a^2 \cdot (1 - tx)}{-\frac{(kE - 1) \cdot a}{q - b} \cdot q^2 + \frac{(kE - 1) \cdot a}{q - b} \cdot (a + 2 \cdot b) \cdot q - a \cdot b - \frac{(kE - 1) \cdot a}{q - b} \cdot b^2} - q$$

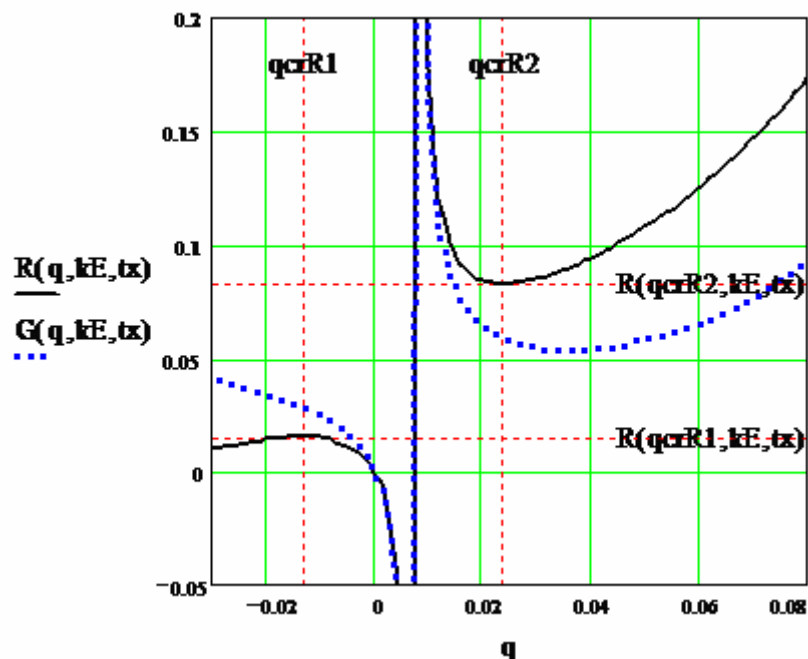

- The optimum level for the sustainability function, G , is obtained for a growth rate, q , of 3.6%.

- In the case of growth rates higher than 7% or lower than 1.5-2% the sustainability is dramatically compromised.
- In the case of the interest function, the optimum level is obtained for a growth rate, q , of 2.4%.
- In the case of a growth rate of 7% the corresponding interest rate continues to be below 15% (Note: the simulation data and computed coefficients are referring to the whole period 1993-2001).

The Simple Econometric Model

The Simple Econometric Model based on a production function in which FDI and exports are introduced as inputs in addition to labour and domestic capital.

FDI is considered the prime source of human capital and new technology to developing (transition) countries and this variable is included in the production function in order to capture the externalities, learning by watching and spillover effects associated with it. We also introduce exports as an additional factor input into the production function, following the large number of empirical studies that investigate the export-driven growth hypothesis. In the usual denotation, the production function can be written as follows:

$$Y = g(Lm, X, K, F, t) \quad (8)$$

where Y is GDP in real terms; Lm - labour input; X – exports; K - domestic capital stock; F - stock of foreign capital; and t - a time trend, capturing technical progress.

Assuming (8) to be linear in logs, taking logs and differencing we obtain the following expression describing the determinants of the rate of GDP growth:

$$y = b_0 + b_1lm + b_2x + b_3k + b_4f \quad (9)$$

where lower case letters denote the rate of growth of individual variables and the parameters b_0, b_1, b_2, b_3, b_4 are output elasticity of labour, exports, domestic capital, and foreign capital, respectively.

In this case, the macroeconomic factors in principle affect economic growth through all four factors on the right side of equation (9).

In the view of the well-known and formidable problems associated with the attempts to evaluate the capital stock, we followed the previous studies by approximating the growth rate of capital stock by the share of investment in GDP. Replacing the rates of change in domestic and foreign capital inputs by the share of domestic investment and foreign direct investment in GDP yields the following growth equation:

$$y = b_0 + b_1lm + b_2x + b_3id + b_4f \quad (10)$$

We estimated the model on the basis of statistical data for Romania for the period 1989-2002, where y is annual rate of real GDP; lm - rate of employment; x - rate of exports; id - share of domestic capital formation (fixed capital) in GDP ($id=Id/Y$); and f - share of FDI (stock) in GDP ($f= F/Y$).

To avoid some inconsistency of data in domestic currency and prices, all statistical data were changed into PPP 2000 USD in case of variables x, id , and f (employment was considered as the annual average level). The results obtained when model (10)

was estimated are reported in Table of Appendix 1. Also, the graphical representation of the results is shown in Figures 1 (where “e” attached to y and Y means “estimated”; yL and yU are delimiting the confidence interval YLower 95% and respectively YUpper 95%).

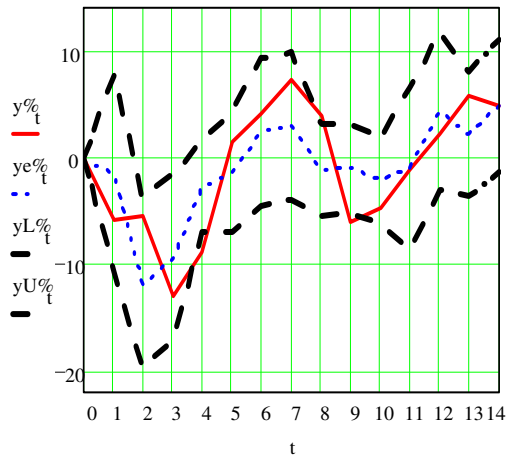

Figure 1a

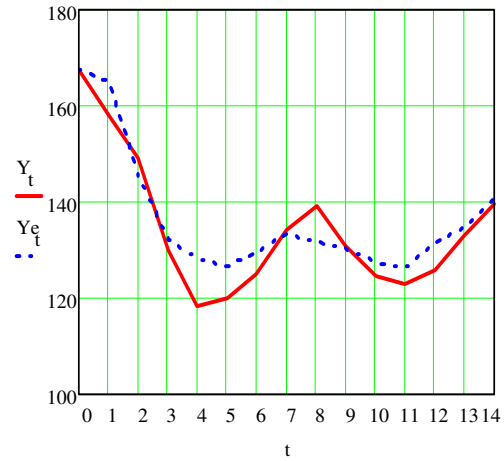

Figure 1b

The Standard Cobb-Douglas Model

Case A (α unknown)

The technological constraint facing producers is described by a Cobb-Douglas production function:

$$Y = AL^\alpha K^{1-\alpha} \quad (11)$$

In accordance with the approach initiated by Solow, the scale parameter “A” measures the total factor productivity and incorporates Hicks-neutral technical change. Demands for production factors (labour, noted here as L_m , and capital, K) are derived in the lines of the so-called marginal productivity rules.

In order to estimate the two remained parameters, A and α , by the standard LSM (applied on logs of variables), firstly we obtained their analytic solution (see Appendix 2). Many apparently insurmountable problems occurred in using available statistical data on capital stock expressed in national currency. They are indeed correctly registered, in accordance with the current accountancy practice, but in the case of using data for estimating parameters of the production function we were forced to operate certain changes.

Firstly, we used the so-called balance of fixed capital stock and evaluated for 1989 and 1990 its analytic structure and certain derived indicators (among the key-parameter is the capital-output ratio, cK) as they are presented in Table of Appendix 3 (only for these two years analytic data were available). Then, we tried many simulation variants in order to obtain compatible results, either with the standard theory or with other studies on the Romanian economy. Referring to the latter, some important discrepancies among different research reports could be mentioned (Maniu,

Kallai, Popa, 2001; IMF Country Report, 2003; Tarhoaca and Croitoru, 2003). Thus, the first one is using 5% as depreciation rate of the fixed capital. The second is using a decreasing rate of the depreciation rate from 20% in 1990 to 10% in 2000 and attributed to the parameter α values between 0.67-0.5. Also, they used the hypothesis of a capital-output ratio around 1.3 for Romania (comparing to 4.6 in case of Germany in 1990). The third study supposed a depreciation rate of 10% and a value of 0.465 for the parameter α .

We tried in our simulations of the model to obtain a reconciliation between the extreme cases. Thus, in the case of Romanian economy, the simulation results (based on considering GDP and Capital stock in PPP \$ in 2000 constant prices) are presented in Table of Appendix 4.

Case B (α given)

There were certain assumptions that we used:

- α given (by computing the share of wages in GDP in each year of the period 1990-2002);
- three hypotheses on the depreciation rate (δ):
 - 1) δ_{mp} (GDP and Capital Stock evaluated in \$ market prices);
 - 2) δ_{PPP} (GDP and Capital Stock evaluated in PPP \$ in constant prices 2000);
 - 3) $\delta_{fix}=0.07$ (GDP and Capital Stock evaluated in PPP \$ in constant prices 2000).

The first hypothesis was considered only for experimental reason (in this case the growth rates of GDP are not realistic, being influenced mainly by the variation in the exchange rate ROL/USD; as they are for instance in the following years: -32.2% in 1992, +34.7% in 1993, -0.8% in 1996, +19.8% in 1998, +15.4% in 2002). Several reported simulation results are presented in Figures 2a and 2b (3-D representations), and in the following Table (where rY is the annual GDP growth rate, and rYL , rYK , and $rYTFP$ – the contribution of factors to it, respectively labour, L, capital, K, and total factor productivity, TFP).

t	rY_t	rYL_t	rYK_t	$rYTFP_t$	rYL_{PPP_t}	rYK_{PPP_t}	$rYTFP_{PPP_t}$	rY_{mp_t}	rYL_{mp_t}	rYK_{mp_t}	$rYTFP_{mp_t}$
1990	-5.6	0.1	4.7	-10.4	0.1	2.6	-8.2	-28.7	0.1	2.6	-31.4
1991	-12.9	-0.5	1.4	-13.9	-0.5	1.7	-14.1	-24.3	-0.5	1.6	-25.5
1992	-8.9	-1.0	-0.1	-7.8	-1.0	-0.4	-7.5	-32.2	-1.0	-0.3	-30.9
1993	1.5	-1.7	0.6	2.5	-1.7	-0.7	3.9	34.7	-1.7	-0.7	37.1
1994	4.0	-1.0	0.4	4.6	-1.0	0.1	4.9	14.0	-1.0	0.1	14.9
1995	7.2	-1.2	1.2	7.3	-1.2	1.3	7.1	17.9	-1.2	1.3	17.9
1996	4.0	-1.4	1.7	3.7	-1.4	2.4	3.0	-0.8	-1.4	2.3	-1.7
1997	-6.1	-1.1	2.2	-7.1	-1.1	2.6	-7.5	0.3	-1.1	2.6	-1.2
1998	-4.7	-1.1	1.3	-4.9	-1.1	2.0	-5.6	19.3	-1.1	2.1	18.3
1999	-1.2	-1.5	0.1	0.2	-1.5	1.7	-1.4	-15.4	-1.5	1.7	-15.6
2000	2.2	-0.5	-0.0	2.7	-0.5	0.7	2.0	3.7	-0.5	0.6	3.5
2001	5.7	0.4	0.3	5.0	0.4	1.0	4.3	7.3	0.4	1.0	5.9
2002	4.9	0	0.9	4.0	0	1.8	3.1	15.4	0	1.8	13.6

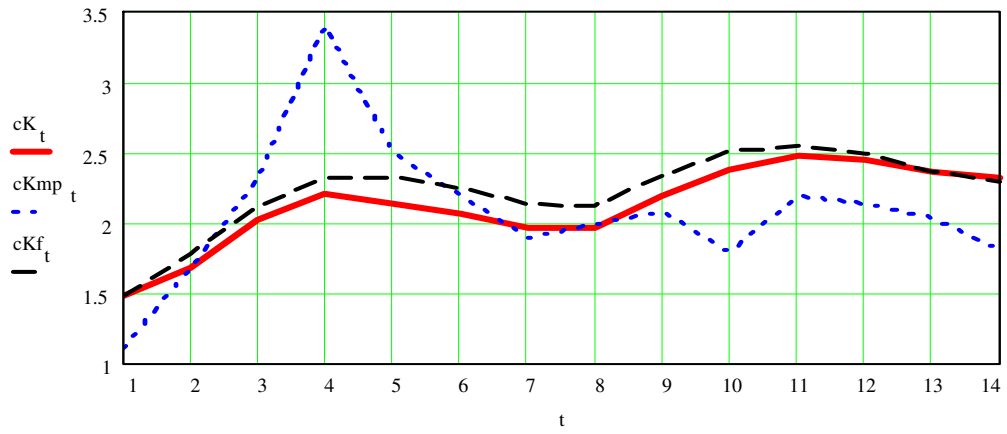
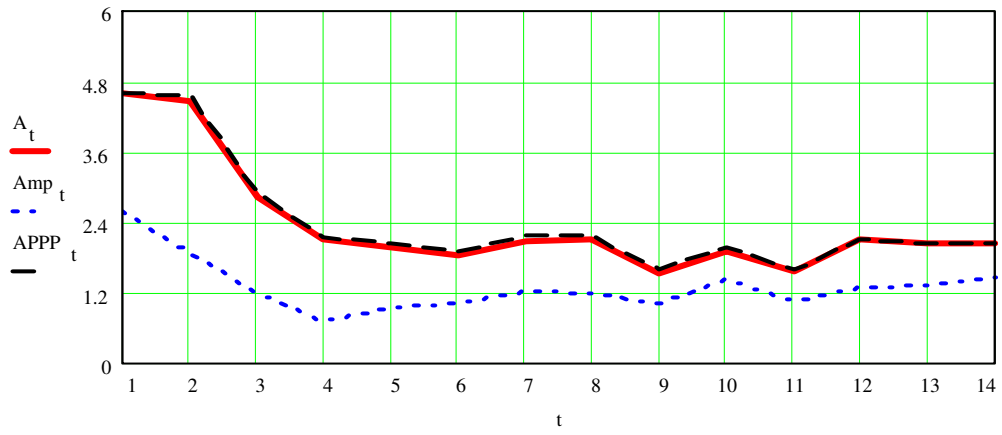
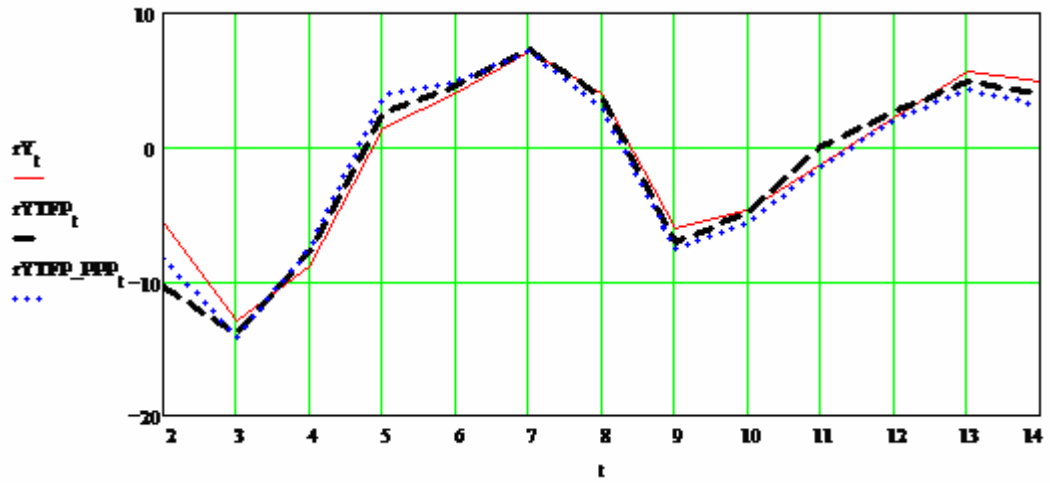

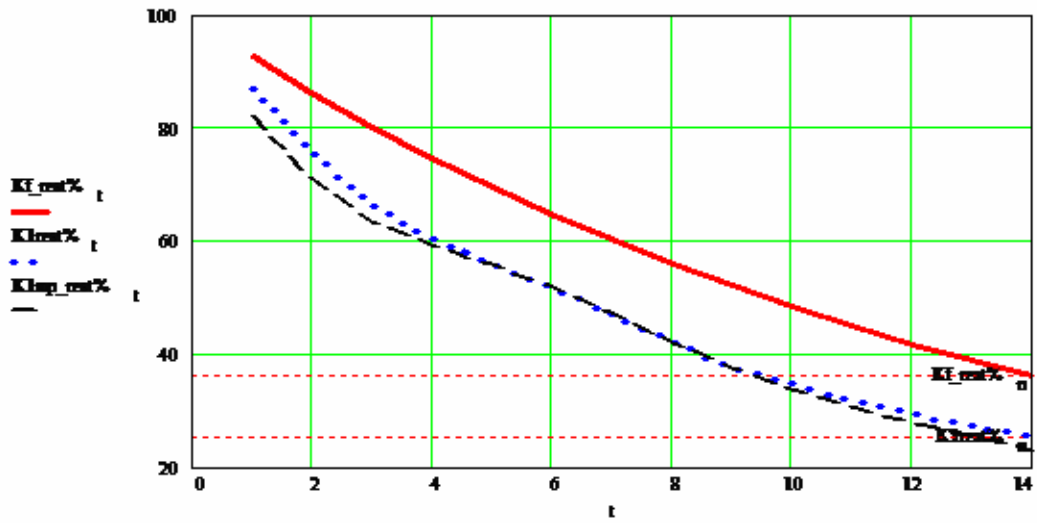
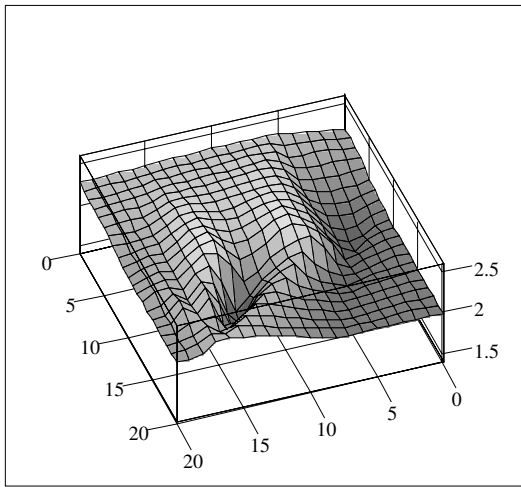
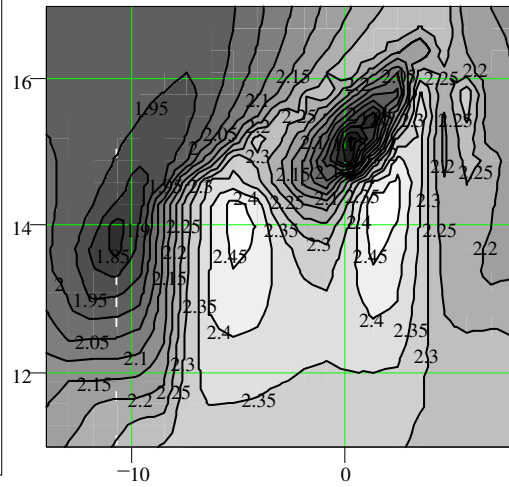

Figure 2a



$rYTfP, wL, cKf$



$rYTfP, wL, cKf$

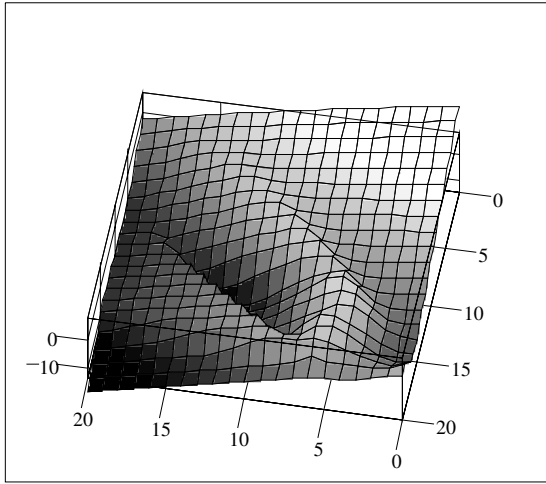

$\alpha, cKf, rYTFP$

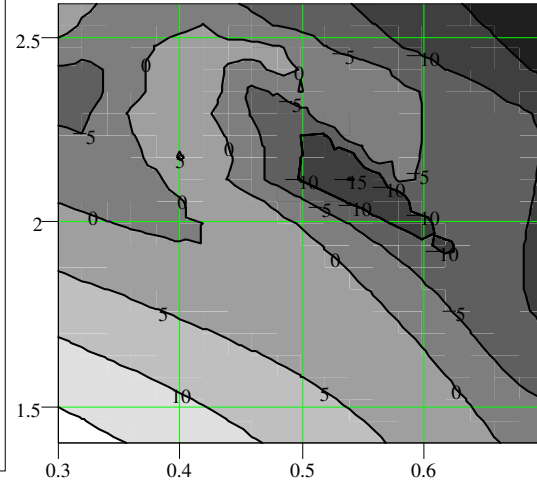

$\alpha, cKf, rYTFP$

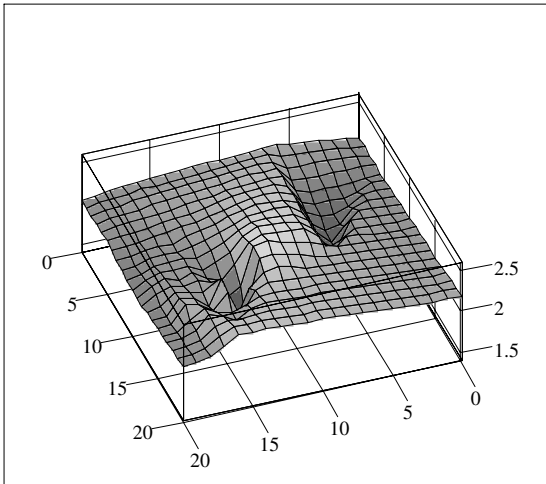

$rYTFP_PPP, wL, cK$

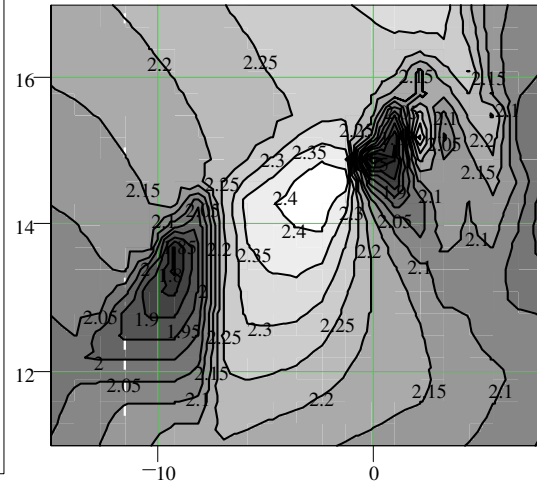

$rYTFP_PPP, wL, cK$

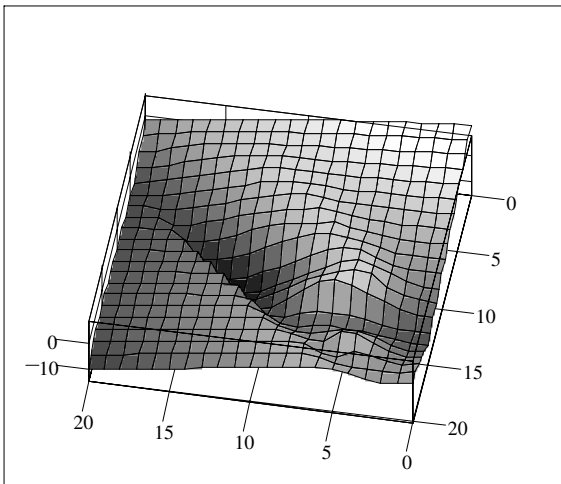

$\alpha, cK, rYTFP_PPP$

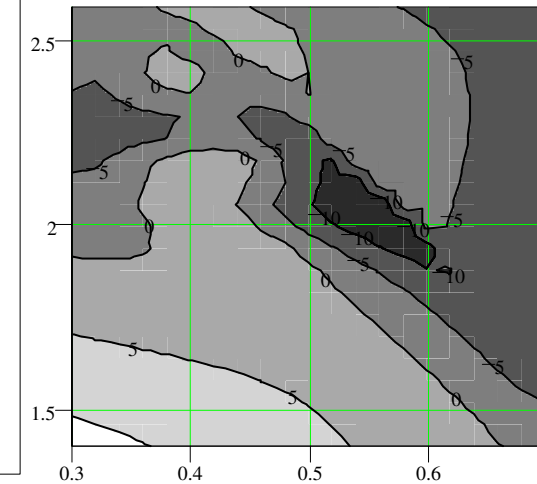

$\alpha, cK, rYTFP_PPP$

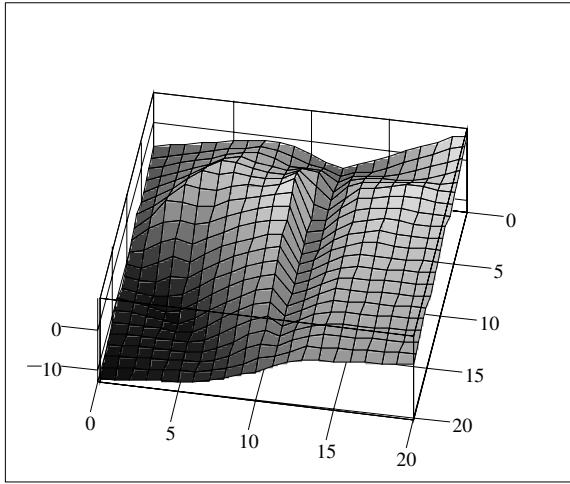

α, wL, rY

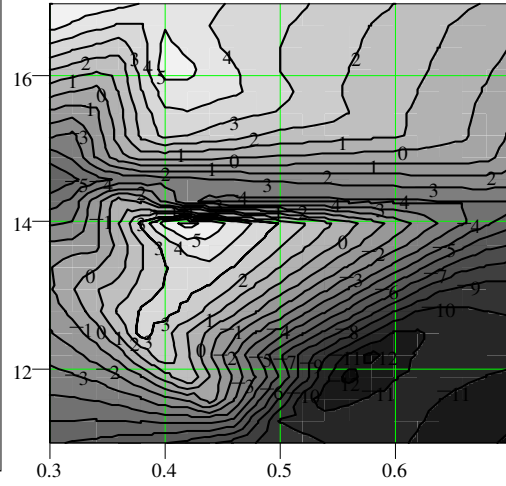

α, wL, rY

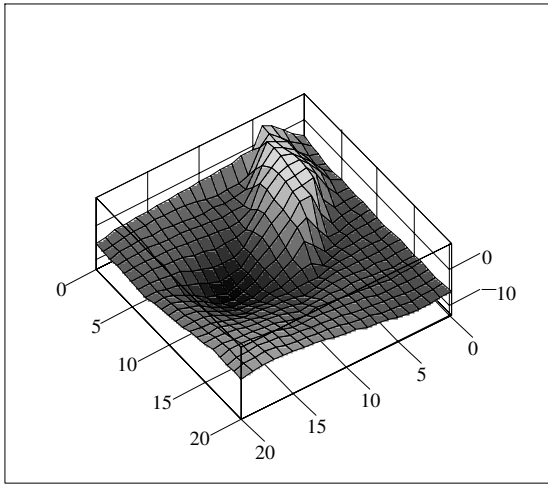

α, δ, rY

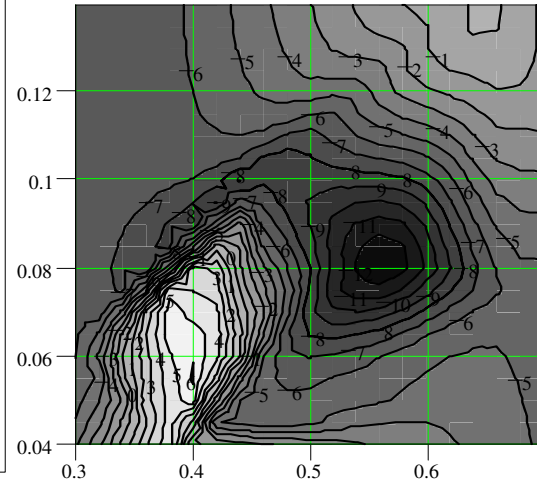

α, δ, rY

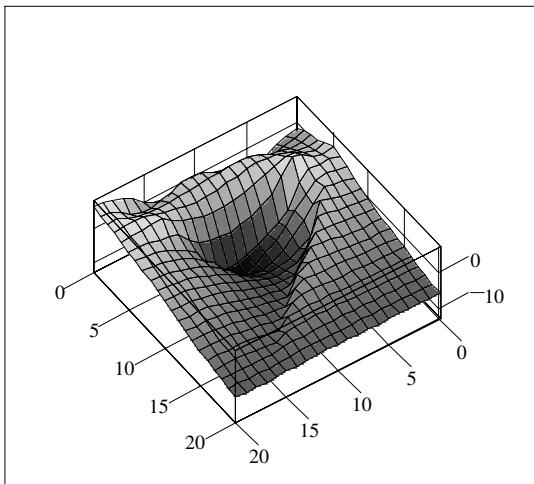

rYL, rYK, rY

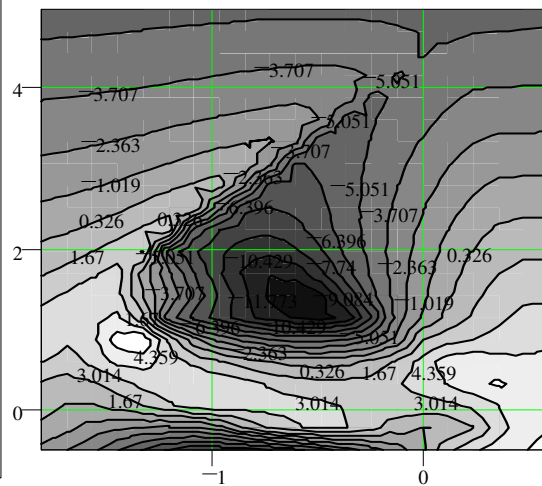

rYL, rYK, rY

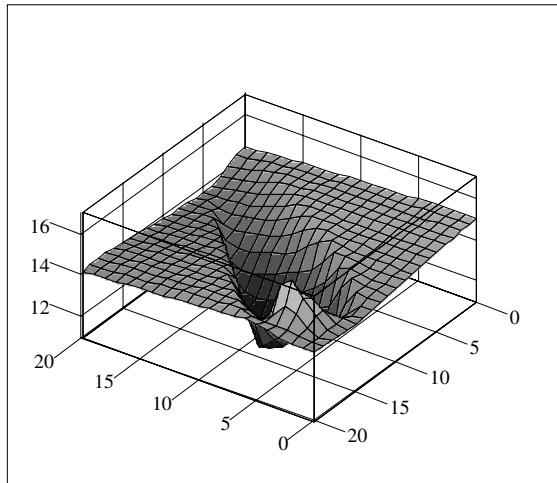

α, cK, wL

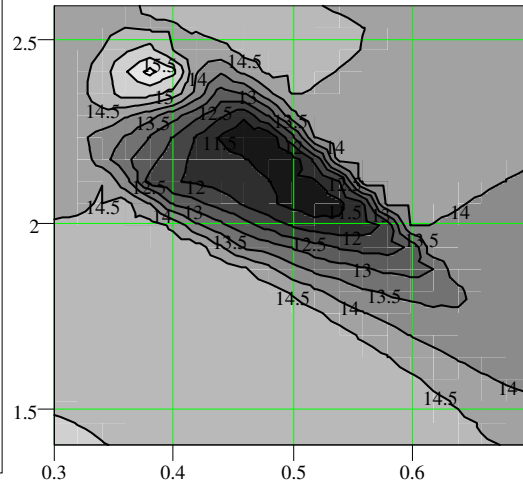

α, cK, wL

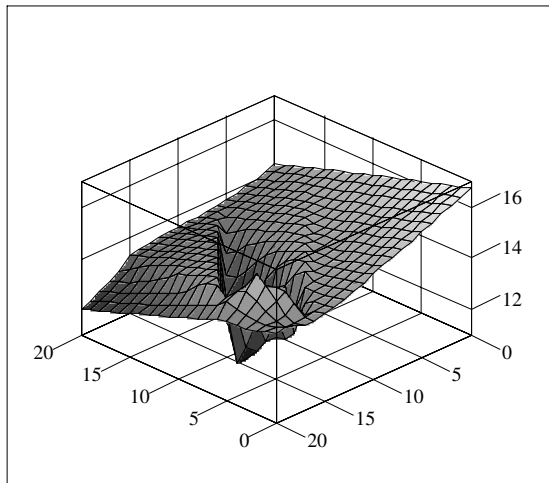

α, cKf, wL

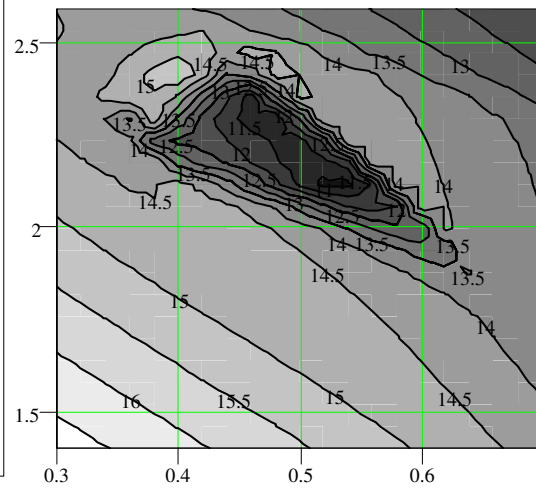

α, cKf, wL

Figure 2b

Appendix 1

Regression Analysis of Determinants of GDP Growth in Romania

Sample	1989-2002
b0	-8.012162043 (-0.9253739218)
b1	0.1090940275 (0.1574818229)
b2	0.2576410339 (0.6470957158)
b3	0.15745828 (0.7495163082)
b4	0.1942923457 (2.581990261)
R ² (Coefficient of Determination)	0.5811312531
Durbin-Watson Ratio	2.2898888

Appendix 2

$$\begin{pmatrix} a \\ \alpha \end{pmatrix} := \begin{bmatrix} \frac{(-slmsklm_k+ slmsylm_k- sk \cdot sylm_k- sy \cdot slmlm_k+ sy \cdot sklm_k+ sk \cdot slmlm_k)}{(-n \cdot slmlm_k+ n \cdot sklm_k+ slm_kslm- slm_ksk)} \\ \frac{-(-slm_ksy - n \cdot sklm_k+ slm_ksk + n \cdot sylm_k)}{(-n \cdot slmlm_k+ n \cdot sklm_k+ slm_kslm- slm_ksk)} \end{bmatrix}$$

where:

$$a = \log(A) \quad sy := \sum_{t=1}^n y_t \quad slm := \sum_{t=1}^n lm_t \quad sk := \sum_{t=1}^n k_t$$

$$slm_k := \left[\sum_{t=1}^n (lm_t - k_t) \right] \quad slmlm_k := \sum_{t=1}^n lm_t \cdot (lm_t - k_t)$$

$$sklm_k := \sum_{t=1}^n k_t \cdot (lm_t - k_t) \quad sylm_k := \sum_{t=1}^n y_t \cdot (lm_t - k_t)$$

Appendix 3

The state of fixed capital stock in 1989 and 1990

Indicator	Unit	Details	1989	1990
K0	Lei (billion)	Capital stock at 1 Jan.	3359	3526
K0\$*	USD (million)		118985	127448
K0*	Lei (billion)		1904	1439
K1	Lei (billion)	Capital stock at 31 Dec.	3526	3498
K1\$*	USD (million)		64155	67244
A	Lei (billion)	Consumption of K (Amortization)	103.5	100.5
A\$	USD (million)		6469	4480
I	Lei (billion)	Investment	238.9	169.8
I\$	USD (million)		14931	7570
D	Years	Average period of using = K0/A	32.5	35.1
V	Years	Average age = K1/I	14.1	20.8
V*	Years	Average age = K1\$*/A\$	18.4	14.3
U	%	Average degree of depreciation = v/d	43.3	59.2
δ*	%	Average annual depreciation rate = 1/ v*	5.4	7.0
cK*	-	$cK^* = K^*/Y0\$ = [(K0\$^*+K1\$^*)/2]/Y$	2.46	1.72

Appendix 4

Results of simulation in case of various values attributed to parameters α and δ (1989-2002)

Years	$\delta=0.01 \alpha=0.595$		$\delta=0.02 \alpha=0.563$		$\delta=0.03 \alpha=0.525$		$\delta=0.04 \alpha=0.480$		$\delta=0.05 \alpha=0.426$		$\delta=0.06 \alpha=0.360$	
	wK	cK	wK	cK	wK	cK	wK	cK	wK	cK	wK	cK
1989	1.006	0.994	0.995	1.005	0.985	1.015	0.975	1.026	0.965	1.036	0.955	1.047
1990	0.596	1.677	0.596	1.677	0.596	1.677	0.596	1.677	0.596	1.677	0.596	1.677
1991	0.406	2.464	0.410	2.442	0.413	2.419	0.417	2.397	0.421	2.375	0.425	2.353
1992	0.263	3.806	0.268	3.738	0.272	3.670	0.278	3.603	0.283	3.537	0.288	3.471
1993	0.340	2.941	0.349	2.863	0.359	2.787	0.369	2.711	0.379	2.638	0.390	2.566
1994	0.369	2.709	0.382	2.616	0.396	2.526	0.410	2.438	0.425	2.353	0.440	2.271
1995	0.409	2.445	0.426	2.345	0.445	2.249	0.464	2.156	0.484	2.067	0.505	1.981
1996	0.376	2.658	0.395	2.535	0.414	2.417	0.434	2.304	0.455	2.197	0.477	2.095
1997	0.346	2.889	0.365	2.740	0.385	2.599	0.406	2.465	0.428	2.339	0.450	2.220
1998	0.390	2.561	0.414	2.415	0.439	2.279	0.465	2.150	0.493	2.030	0.522	1.917
1999	0.309	3.233	0.330	3.032	0.351	2.846	0.374	2.672	0.398	2.511	0.424	2.361
2000	0.309	3.236	0.331	3.017	0.355	2.815	0.380	2.628	0.407	2.456	0.435	2.296
2001	0.322	3.104	0.347	2.878	0.374	2.671	0.403	2.481	0.433	2.308	0.465	2.148
2002	0.347	2.878	0.376	2.656	0.407	2.455	0.440	2.271	0.475	2.104	0.512	1.953

$\delta=0.07 \alpha=0.279$		$\delta=0.08 \alpha=0.177$		$\delta=0.09 \alpha=0.045$		$\delta=0.10 \alpha=-0.126$		$\delta=0.11 \alpha=-0.348$		$\delta=0.12 \alpha=-0.622$		$\delta=0.13 \alpha=-0.887$	
WK	cK	wK	cK	wK	cK	wK	cK	wK	cK	wK	cK	wK	cK
0.945	1.059	0.935	1.070	0.924	1.082	0.914	1.094	0.904	1.106	0.894	1.119	0.884	1.132
0.596	1.677	0.596	1.677	0.596	1.677	0.596	1.677	0.596	1.677	0.596	1.677	0.596	1.677
0.429	2.330	0.433	2.308	0.437	2.286	0.442	2.264	0.446	2.241	0.451	2.219	0.455	2.197
0.294	3.406	0.299	3.341	0.305	3.277	0.311	3.214	0.317	3.152	0.324	3.090	0.330	3.029
0.401	2.495	0.412	2.425	0.424	2.358	0.437	2.291	0.449	2.226	0.463	2.162	0.476	2.099
0.456	2.191	0.473	2.113	0.491	2.037	0.509	1.964	0.528	1.893	0.548	1.824	0.569	1.758
0.527	1.899	0.550	1.820	0.574	1.743	0.599	1.670	0.625	1.600	0.652	1.533	0.681	1.468
0.501	1.998	0.525	1.905	0.550	1.817	0.577	1.733	0.605	1.653	0.634	1.577	0.665	1.505
0.475	2.107	0.500	2.001	0.526	1.901	0.554	1.806	0.582	1.717	0.612	1.633	0.644	1.554
0.552	1.811	0.584	1.712	0.617	1.620	0.652	1.533	0.689	1.452	0.727	1.376	0.766	1.305
0.450	2.221	0.478	2.091	0.508	1.970	0.538	1.858	0.570	1.754	0.603	1.657	0.638	1.567
0.465	2.149	0.497	2.014	0.529	1.889	0.564	1.773	0.600	1.667	0.638	1.568	0.677	1.477
0.499	2.002	0.535	1.869	0.573	1.746	0.612	1.634	0.653	1.531	0.696	1.436	0.741	1.350
0.551	1.815	0.592	1.689	0.635	1.575	0.680	1.471	0.727	1.376	0.776	1.289	0.826	1.211

$\delta=0.14 \alpha=-0.919$		$\delta=0.15 \alpha=-0.420$		$\delta=0.16 \alpha=0.371$		$\delta=0.17 \alpha=0.940$		$\delta=0.18 \alpha=1.216$		$\delta=0.19 \alpha=1.325$		$\delta=0.20 \alpha=1.355$	
WK	cK	wK	cK	wK	cK	wK	cK	wK	cK	wK	cK	wK	cK
0.874	1.145	0.863	1.158	0.853	1.172	0.843	1.186	0.833	1.201	0.823	1.215	0.813	1.231
0.596	1.677	0.596	1.677	0.596	1.677	0.596	1.677	0.596	1.677	0.596	1.677	0.596	1.677
0.460	2.175	0.465	2.152	0.469	2.130	0.474	2.108	0.479	2.086	0.485	2.064	0.490	2.041
0.337	2.968	0.344	2.908	0.351	2.849	0.358	2.790	0.366	2.732	0.374	2.675	0.382	2.619
0.491	2.038	0.505	1.978	0.521	1.920	0.537	1.863	0.554	1.807	0.571	1.752	0.589	1.698
0.591	1.693	0.613	1.631	0.637	1.570	0.661	1.512	0.687	1.455	0.714	1.401	0.742	1.348
0.711	1.406	0.742	1.347	0.775	1.290	0.809	1.236	0.845	1.183	0.882	1.134	0.921	1.086
0.696	1.436	0.729	1.371	0.764	1.309	0.800	1.251	0.837	1.195	0.876	1.142	0.916	1.092
0.676	1.479	0.710	1.409	0.745	1.343	0.781	1.280	0.819	1.222	0.857	1.166	0.897	1.115
0.808	1.238	0.850	1.176	0.894	1.118	0.940	1.064	0.987	1.013	1.035	0.966	1.085	0.921
0.674	1.484	0.711	1.406	0.749	1.334	0.789	1.268	0.830	1.205	0.871	1.148	0.914	1.094
0.717	1.394	0.760	1.316	0.803	1.245	0.848	1.179	0.894	1.118	0.942	1.062	0.990	1.010
0.787	1.270	0.835	1.198	0.884	1.131	0.935	1.069	0.987	1.013	1.041	0.961	1.095	0.913
0.878	1.139	0.932	1.073	0.987	1.014	1.043	0.959	1.100	0.909	1.159	0.863	1.218	0.821

Selected Bibliography

Balasubramanyam, V. N., M. Salisu and D. Sapsford (1996): *Foreign Direct Investment and Growth in EP and IS Countries*. The Economic Journal. Vol. 106, No. 434, January, 92-105.

Barro, R. J. (1991): *Economic Growth in a Cross Section of Countries*. Journal of Economics. Vol. CVI, May, Issue 2, 407-443.

Emilian Dobrescu (2000): *Macro-models of the Romanian Transition Economy*, third edition, Expert Publishing House.

Fischer, S. (1993): *The Role of Macroeconomic Factors in Growth*. Journal of Monetary Economics, Vol. 32, 485-512.

Mircea T. Maniu, Ella Kallai, Dana Popa (2001): *Explaining Growth - Country Report: Romania (1990-2000)*, GLOBAL RESEARCH PROJECT, Second Draft, December 13-14, Rio de Janeiro.

Neven Mates, Andreas Westphal, Nicolay Gueorguiev, Nicolas Carnot, Thomas Harjes and Subir Lall (2002): *Romania – Selected Issues and Statistical Appendix*, IMF Country Report No. 03/12.

Rossitsa Rangelova (2002): *Economic assessment and catching-up the EU standards: the case of CEECs*, The 7th EACES Conference "GLOBALISATION AND ECONOMIC GOVERNANCE", 6-8 June, Forli (Bologna, Italy).

Solow, R. M. (2000): *Toward a Macroeconomics of the Medium Run*. Journal of Economic Perspectives. Vol. 14, No 1, Winter, 151-158.

Tarhoaca Cornel and Croitoru Lucian (2003): *The Romanian growth potential – a CGE analysis*. Paper prepared for the *Regional Partnership Project Conference*, St. Petersburg, Russia, June 7-9.