



Munich Personal RePEc Archive

**Influence of corporate social
responsibility on development of
corporate reputation and customer
purchase intentions**

Ali, Imran

COMSATS Institute of Information Technology Lahore, Pakistan

2011

Online at <https://mpra.ub.uni-muenchen.de/33889/>
MPRA Paper No. 33889, posted 05 Oct 2011 19:46 UTC

Influence of Corporate Social Responsibility on Development of Corporate Reputation and Customer Purchase Intentions

Imran Ali

Assistant Professor, Department of Management Sciences
COMSATS Institute of Information Technology Lahore, Pakistan
E-mail: imranalinim@gmail.com

Abstract

The concept of corporate social responsibility (CSR) has gained wide consideration in academic field as well as in business world in recent years. Organizations are using CSR to develop competitive advantage and establish congenial relations with its stakeholders. Despite the popularity of CSR in the developed world, the potential benefits of CSR are less emphasized in the developing economies like Pakistan. This study examines the influence of CSR on development of corporate reputation and purchase intentions in the cellular industry of Pakistan. The data has been collected from the respondents regarding their perceptions about CSR actions and its influence on their reputation and customer purchase intentions. Structural equation modeling technique is used to analyze data and test hypotheses. The study found significantly positive influence of CSR on building corporate reputation of doing good and developing customer purchase intentions. The study provides useful recommendations for the policy makers in corporate world. It also contributes towards literature on CSR, Corporate reputation and customer behavior and offer direction for future researchers.

Key Words: Corporate social responsibility, corporate reputation, customer purchase intentions, developing economy, structural equation model, Pakistan.

Introduction

Corporate social responsibility has become the mumble word in recent years. Studies are being conducted to explore the potential benefits of CSR across the globe and across the disciplines. Increasingly corporations are engaging generous financial resources to develop image of doing good to strengthen its relationships with all stakeholders particularly customers, employees, investors, government and the community. The corporate image of doing well also develops builds good corporate reputation. Corporations capitalize the good market reputation in numerous ways. Moreover it today's competitive economy it became very difficult for corporations to ensure sustainable growth. Corporate social performance and good corporate reputation help organization to achieve sustainable growth in the market by attracting and retaining customers, employees and investors. Many studies admitted that loyal customers, employees and investors contribute towards success of organizations. However, current study only examines the perceptions of customers only regarding CSR and corporate reputation. Companies are increasing concentrating on increasing consumer awareness regarding their CSR actions. Therefore it is becoming part of their advertising campaigns; it is also being displayed on their websites for wider publicity. Mostly corporations

concentrate on education, health, poverty, entertainment, and environmental issues in their CSR interventions.

The cellular industry of Pakistan is selected for examination in this study. The rationale behind selection of cellular industry is its rapid expansion in the last decade. Valdecantos (2009) stated that cellular industry of Pakistan is experiencing 100 % growth rate since many years. Pakistan Telecommunication Authority (PTA) also declared cellular industry of Pakistan as one of the fastest growing industry in the region. Moreover, the cellular industry of Pakistan is also undergoing intense oligopolistic competition. An oligopolistic competition is attributed where only few players exist in the market that closely observe and follow each other. The leading cellular company in Pakistan also claims to be the biggest contributor in the field of corporate social responsibility. As a result other cellular service providers also started to point out some attention demanding areas in the society of Pakistan to address its issues through conducting CSR activities. The cellular companies are also marketing their CSR actions in the society in order to build reputation of doing good and gain sympathies of customer and other stakeholders. Some studies have also documented the influence on consumer perceptions of CSR on their behavior. For instance Ali et al. (2010) investigated the causal relationship of CSR and service quality on customer satisfaction and retention in the cellular industry of Pakistan.

The objective of this study is three fold, firstly to examine the influence of CSR actions on development of corporate reputation, secondly measuring its affect on customer purchase intentions and finally, to gauge the impact of corporate reputation on customer purchase intentions. The subsequent sections present review of relevant literature, research methodology adopted for this inquiry, results and their discussion and finally conclusion and useful recommendations.

Identification and Integration of Variables

Corporate Social Responsibility and Corporate Reputation

Corporate social responsibility often known as corporate social performance, corporate citizenship, and corporate social accountability is one of the topics being rigorously researched today by the academic researchers. Corporate social responsibility is defined by many authors in various fashions. This study follows the definition of CSR by Mohr et al. (2001) who believed CSR as “a company’s commitment to minimizing or eliminating any harmful effects and maximizing its long run beneficial impact on society”. The concept of CSR became popular in 1950s when Bowen (1953) instigated the business people to contribute towards community development all around their corporate policies. Followed by Manne (1972); Beyer (1972); Drucker (1974); Carson (1977), numerous business schools, labor leaders, consumer advocators and environmental activists, who strongly supported the conception of social accountability. The notion of social accountability holds those corporations are minting money from the society using natural resources which are scarce and diminishing; moreover mass production of corporations is also damaging environment and eco system. Therefore the corporations must payback to

the community and address the issue of environmental degradation and heal concerns of the society.

In 1990s, socially responsible interventions of corporations displayed much larger role than actually predicted by people. Corporations undertook broader social responsibilities including business ethics, labor practices, and responsibility to community at large and reducing environmental harms of their mass productions and other social actions they believed when shaping an image of companies in the society. This emphasizes the significance of the 'softer' image of corporate reputation. With the passage of time societal expectations of companies have increased of community welfare. Globally, customers suppose companies to be responsible for different actions, ranging from ensuring quality in products at the cheaper prices, to environmental protection, to treating employees fairly; to helping solve social and economic issues faced by the community. With expectations for corporate responsibility rising, the adoption of CSR as a business is becoming more inevitable.

H1: Corporate reputation is positively influenced by corporate social responsibility.

Corporate Social Responsibility and Consumer Purchase Intentions

Numbers of studies have investigated the relationship between corporate social responsibility on behavior of various stakeholders, for instance Ali et al. (2010a) analyzed the affects of CSR on consumer behavior. Similarly, Ali et al. (2011) investigated the influence of CSR on investor behavior. Ali et al (2010c) also examined the influence on CSR on employee behavior towards organization. In the context of consumer purchase intentions Holmes and Kilbane, (1993); Berger et al. (1999); Mohr et al., (2001); Nelling and Webb (2006); and Sen and Bhattacharya (2001) also investigated the affects of CSR on consumer purchase intentions.

H2: Consumer purchase intentions are positively influenced by corporate social responsibility.

Corporate Reputation and Consumer Purchase Intentions

The notion of corporate reputation appeared from corporate image in 1950's and evolved into corporate identity in 1970's and 1980's (Bennett and Kottasz, 2000). Corporation reputation as defined Fombrun (1996) is based on a set of collectively held beliefs about a company's ability and willingness to satisfy the interests of various stakeholders. Bromley (2002) and Sandberg (2002) viewed reputation as a socially shared impression and a consensus about how firm will behave in any given situation. Notable contribution in the field of corporate reputation is produced by Fombrun and van Riel (1997) who highlighted the diverse perspectives on corporate reputation. Gray and Balmer (1998); and Baranett et al. (2006) also hold that good corporate reputation is the source of survival in today's competitive environment. Ali (2011) also examined the influence of corporate reputation in consumer behavior in cellular industry of Pakistan.

H3: Consumer purchase intentions are positively influenced by corporate reputation.

Research Methods

Sample and Sampling

This research is exploratory in nature; the primary data has been collected through structured questionnaire survey which was personally administered. A total of 400 questionnaires were distributed to the respondents. The respondents in this study were university students from both genders, different ages and various academic programs of management sciences. The student being users of cellular services having awareness of the concept of corporate social responsibilities in different subjects can best serve the purpose for this survey. The study used purposive sampling technique. The logic behind using this technique that generally customers do not know the concept of corporate social responsibility, therefore they do not incorporate this factor in their purchase decision. As pointed out by Ali et al. (2010a) the level of CSR awareness in customers in Pakistan is very less. Cellular study of Pakistan has also been previously selected by Ali et al. (2010b) for data collection regarding customer perceptions.

Measurement and Instrumentation

There are two dependent variables in this research, firstly the influence of CSR is observed on corporate reputation which is dependent variable in this instance, and secondly influence of CSR is measured on customer purchase intentions i.e. the second dependent variable. The instrument for measuring corporate reputation is adopted from Helm (2007). The instrument contained 10 items incorporating quality of products, qualification of management, financial performance, credibility of advertising claims, value for money of products and other items, fair treatment of employees, customer orientation, commitment to social issues, protection of environment and corporate success. The purchase intention was gauged from the instrument developed by Yi (1990) consisting on three items measured on 7-point bipolar scales. CSR is independent variable in this research. The instrument to measure the CSR awareness of customers is adopted from Wigley (2008). This procedure requires asking some questions regarding CSR actions of some particular organization to check to check the customer awareness and sentiments towards corporations.

Data and Analysis

The data was analyzed through software Statistical Package for Social Sciences (SPSS) and AMOS. Reliability and correlation analysis were performed through SPSS and structural equation model was conducted through AMOS. Structural equation modeling technique is considered as good to the development of theoretical model, hypotheses and finally testing these hypotheses and model fit. The technique is quite popular in exploratory studies of such nature in social sciences.

Results and Discussions

The study is conducted to investigate the causal effects of CSR on corporate reputation and consumer purchase intention. The results obtained from the model fit for this study shows the value of probability (P) as .231, which confirms the model fit adequately, as the value of P should be > 0.05 ; therefore overall model fit meets required criteria. The reliability analysis also produces satisfactory results. The value of cronbach's Alpha is 0.790 which is statistically reliable in research.

Table I: Correlations

		CSR	CR	CPI
Corporate Social Responsibility	Pearson Correlation	1		
	Sig. (2-tailed)			
	N	257		
Corporate Reputation	Pearson Correlation	.580**	1	
	Sig. (2-tailed)	.000		
	N	257	257	
Customer Purchase Intentions	Pearson Correlation	.515**	.635**	1
	Sig. (2-tailed)	.000	.000	
	N	257	257	257

** Correlation is significant at the 0.01 level (2-tailed).

Table I shows the table of correlations. This table reflects variables – corporate reputation and consumer satisfaction – are positively correlated to consumer loyalty ($r = .515$, $p = .000$ and $r = .635$, $p = .000$ respectively). The enormity of correlations of corporate social responsibility and corporate reputation are greater than 0.3 in the absolute terms, which shows the moderate correlations between the said pair of the variables. All the correlations are statistically significant at one percent level of significance.

Table II represents the regression results of this study. In order to accept any hypotheses the value of P should be lesser than .05. The value of P in first case is 0.11 which is well below .05 therefore we accept our *H1*. This means that corporate reputation is strongly and positively influenced by CSR action of corporations. In second case the value of P is .007 which is also well below than 0.05, we accept our *H2* as well. Ali et al (2010a) also found positive influence of corporate social responsibility on consumer behavior in cellular industry of Pakistan. Corporate social responsibility is also influencing positively and significantly on consumer purchase intentions, which is very encouraging for corporations. Because researcher believes that corporations should not consider money spent on CSR as an expense rather investment. This supposition is confirmed here, if increase in CSR budget can enhance sales of corporation then it is really good for corporations. Finally, our third hypothesis is also accepted because the value of P in this case is 0.27, which also meets our hypothesis acceptance criteria. Ali and Zia (2011b) also found positive influence of corporate reputation on consumer behavior.

Table II: Regression Weights

	Hypotheses	Estimate	S.E.	C.R.	P	Decision
H 1	Corporate Reputation - CSR Actions	.804	.127	7.171	.011	Accept
H 2	Consumer Purchase Intentions - CSR Actions	.385	.081	3.221	.007	Accept
H 3	Consumer Purchase Intentions – Corporate Reputation	.750	.067	8.218	.027	Accept

Figure II: Structural Equation Model

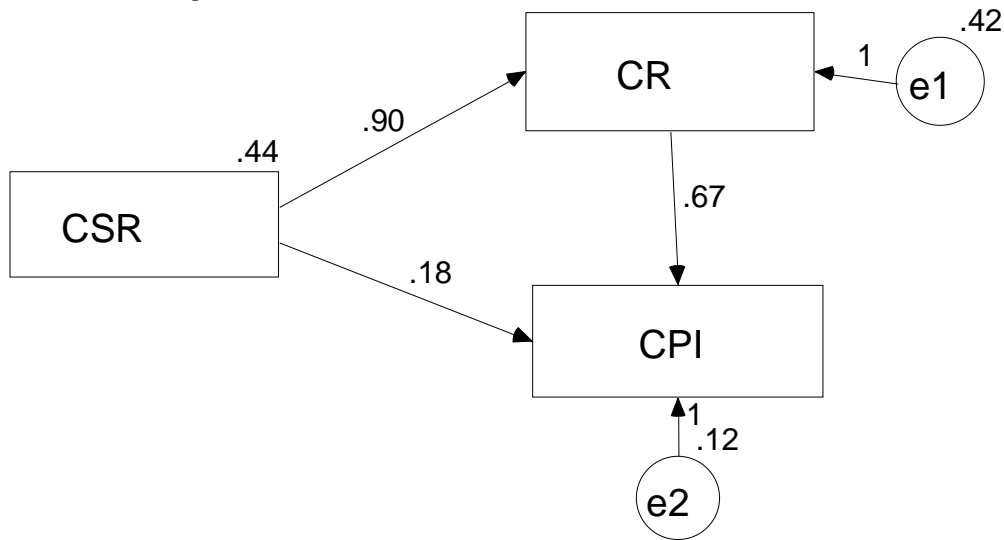

Figure II is depicting the results for structural equation model. It shows the nature of relationship among variables, all three variables in this figure are having positive relationship which is very logical in this case. The structural equation is also having error term on the dependent variables.

Conclusion

This study was conducted to investigate the potential influence of corporate social responsibility on corporate reputation and customer purchase intentions. This is an important research because it provides imperative information for corporate decision makers who are interested to develop some competitive advantage and ensure sustainable growth in the market. The study concluded that corporate social responsibility is having significantly positive influence on corporate reputation and consumer purchase intentions. Moreover, corporation reputation also affects positively and significantly on development of purchase intentions in customers. Therefore customer behavior can be shaped favorably towards corporate products and services by undertaking more social activities and improving reputation of doing well by the corporations. The study recommends that corporations should engage in doing corporate social responsibility

activities and develop good corporate reputation to ensure successful corporate performance in competitive environment. Future researcher can also address the other potential benefits of corporate social responsibilities and corporate reputation in consumer behavior perspectives. The study is conducted in cellular industry of Pakistan; future researchers may also conduct this study in other sectors of Pakistan as well.

Reference:

Ali, I; Rehman, K.U; Yilmaz, A.K; Nazie, S; and Ali, J.F. (2010a). Effects of corporate social responsibility on consumer retention in cellular industry of Pakistan. *African Journal of Business Management*. 4(4):475-485.

Ali, J.F; Ali, I; Rehman, K.U; Yilmaz, A.K; Safwan, N; and Afzal, H. (2010b). Determinants of consumer retention in cellular industry of Pakistan. *African Journal of Business Management*. 4(12):2402-2408.

Ali, I.; Rehman, K.U.; Ali, S. I.; Yousaf, J.; and Zia, M. (2010c). Corporate social responsibility influences on employee retention and organizational performance. *African Journal of Business Management*, 4(13):2796-2801.

Ali, I.; Rehman, K.U.; and Akram, M. (2011). Corporate social responsibility and investor satisfaction influences on investor loyalty, *Actual Problems of Economics* in August 2011 Issue (8), forthcoming.

Ali, I. (2011). Corporate reputation influences consumer satisfaction and loyalty: evidence from cellular industry of Pakistan. Paper presented at International Conference on Challenges for Knowledge Society, held on 15-16 April, 2011 at Bucharest, Romania.

Barnett, M.L.; Jermier, J.M.; and Lafferty, B.A. (2006). Corporate reputation: The definitional landscape. *Corporate Reputation Review*, 9(1):26-38.

Berger, I.E; Cunningham, P.H; Kozinets, R.V. (1999). Consumer persuasion through cause-related advertising. *Advances in Consumer Research*. 26: 491-497.

Bennett, R.; and Kottasz, R. (2000). Practitioners perceptions of corporate reputation: An empirical investigation, *Corporate Communications: An International Journal*, 5(4):224-234.

Drucker PF (1974). *Management: tasks, responsibilities, practices*. New York: Harper & Row.

Fombrun, C. (1996) *Reputation*, Harvard Business School Press, Boston.

Fornell C (1992). A national customer satisfaction barometer: the Swedish experience. *Journal of Marketing*, 56: 6-21

Freeman RE (1984). *Strategic management: A stakeholder approach*. Boston: Pitman.

Friedman M (1970). The social responsibility of business is to increase its profits. *New York Times Magazine*, 13: 32-33, 122, 124, 126.

Graay, E.R.; and Balmer, J.M.T. (1998). Managing corporate image and corporate reputation. *Long Range Planning*, 31(5):695-702.

Helm, S. (2007). The role of corporate reputation in determining investor satisfaction and loyalty. *Corporate Reputation Review*, 10(1):22-37.

Holmes, J.H; and Kilbane, C.J. (1993). Cause-related marketing: Selected effects of price and charitable donations. *Journal of Nonprofit Public Sector Marketing*, 1: 67-83.

Mohr L.A; Webb, D.J; Harris, K.E. (2001). Do consumers expect companies to be socially responsible? The impact of corporate social responsibility on buying behavior. *Journal of Consumer Affairs*, 35: 45-72.

Nelling, E; and Webb, E. (2006). Corporate social responsibility and financial performance: The virtuous circle revisited. Working Paper, Drexel University and Federal Reserve Bank of Philadelphia.

Sen, S; and Bhattacharya, C.B. (2001). Does doing good always lead to doing better? Consumer reactions to corporate social responsibility. *Journal of Marketing Research*, 38(2):225-243.

Valdecantos C (2009). Pricing optimization in Africa: the challenge. Africa Telecommunications Network. Cited on November 03, 2009 from. <http://africatelecommunications.ning.com/profiles/blogs/pricingoptimization-in-africa>.

Wigely, S. (2008). Gauging consumers' response to CSR actions: Does increased awareness makes cents? *Public Relations Review*. 34(3):306-308.