

MPRA

Munich Personal RePEc Archive

Optimizing the Managerial Decision in Energetic Industry

Dura, Codruta and Isac, Claudia

University of Petrosani, Romania

15 May 2007

Online at <https://mpra.ub.uni-muenchen.de/3408/>

MPRA Paper No. 3408, posted 06 Jun 2007 UTC

OPTIMIZING THE MANAGERIAL DECISION IN ENERGETIC INDUSTRY

Ph. D. Lecturer Codruta Dura

Ph. D. Lecturer Claudia Isac

UNIVERSITY OF PETROSANI, ROMANIA

Abstract: *Making a decision is a complex process which must be based upon a method that is able to establish the optimum criteria in choosing an alternative, in evaluating the main effects of implementing the decision which was taken and in estimating the risks involved. The optimizing methods and techniques fall into several groups. Thus, judging by the number of criteria that was taken into consideration when making decisions, the optimization methods and techniques can be identified as uni-criterial decisions and multi-criterial decisions; considering the objective condition state which affects the problem that needs decisional solution, there can be decisional methods and techniques used in optimizing decisions in conditions of certainty, decisional methods and techniques used in optimizing decisions in conditions of uncertainty and decisional methods and techniques used in optimizing decisions in risky conditions. The continuous improvement of the decisional subsystem - an important component of the firm's management - represents a necessity under the circumstances that the latest decades reveal a development of the decisional elements, both in the theoretic-methodological field and in the application field. The decisional methods and techniques must be found in the managers' decisional processes at different hierarchical levels (individual managers or group managers), so that a high scientific materialization level of the methods should be ensured.*

If the concept *optimum* [27] refers to maximizing the target (favorable) effects and/or minimizing the unwanted (unfavorable) effects, than *optimization* means the action which ensures the most favorable situation between the economic effect and the effort involved (maximum profit, minimum costs) [28]. Optimizing a decision can be possible either according to the goal or the pre-established means that lead to its achievement; it is not absolute; it is dependent on the field it is applied into and on the exact circumstances. Thus, an optimum decision for a certain economic context can fall below the optimum level if it is applied for another economic situation or in modified conditions.

The optimizing methods and techniques fall into several groups. Thus, judging by the number of criteria that was taken into consideration when making decisions, the optimization methods and techniques can be identified as uni-criterial decisions and multi-criterial decisions; considering the objective condition state which affects the problem that needs decisional solution, there can be decisional methods and techniques used in optimizing decisions in conditions of certainty, decisional methods and techniques used in optimizing decisions in conditions of uncertainty and decisional methods and techniques used in optimizing decisions in risky conditions [30].

Among **the multi-criterial decision optimizing methods and techniques in conditions of certainty**, the most frequently used ones are: *the additive method*, which is used in case the importance coefficients of the decisional criteria are identical; thus, the optimum variant reaches the highest level for each decisional variant; *the global utility method* which is

used in case decisional criteria have different importance coefficients and the global utility can be determined for each decisional variant; the Onicescu method offers two ways for solving a decisional problem through specific algorithms, the most important one being the incompatibility among methods to set the concordance and discordance indicators that are used in determining the optimum variant; the *Rompedet* method (Romanian Model of Performance Determination) – it is a Romanian model for the determination of performance and it was conceived in 1970 by Ion Stăncioiu; it removes the subjectiveness of the technical and/or qualitative level evaluation of the decisional options; *the Combinex method*, which is set to combine the contributions of each evaluation characteristic or criterion to the global performance of the decisional variants.

The complexity of the economic activities has determined the shaping of the decisional act, which cannot be conceived without the use of computer technology which gathers, processes and send information. Therefore, computers make the link between the decisional subsystem and the information system of the management system, meaning that electronics becomes a working tool in the decision making activity through some specialized software that analyze decisional alternatives materialized in computer aided decisional systems, management simulation programmes and computers. Under the circumstances, for the companies within the energetic industry, creating an “info-structure” of the company based upon computer technology and information procedures becomes a managerial option.

The decision to equip *P* Power Plant with computers is a decision taken in conditions of certainty of the decisional process; in order to materialize this decision the Electre method can be used. This method is a useful tool for the management team, considering the fact that the interest in using modern methods and techniques for the decisions materialization is quite reduced and it is also one of the weak spots of the decisional subsystem of the management, in case of our example regarding *P* Power Plant.

The Electre Method (Elimination et Choix Traduisant la Realite) submitted/suggested for the first time in 1967 by the economist Bertrand Roy is used in solving some complex decisional problems, both from the point of view of the number of variants/options and from the point of view of the decisional criteria which influence the consequences of each variant. It consists in analyzing the pair of variants $V_i (i = \overline{1, m})$ according to several criteria $c_j (j = \overline{1, n})$ and in separating the variants based on two categories of concordance and discordance indicators which are useful at drawing up, iteratively, the priority graph of the variants.

In order to materialize the decision taken for *P* Power Plant using this method, we face a complex process which implies taking the following steps [3]:

- *Putting down the objectives of the decision in the task book of the auction event./ Including the objectives of the decision in the conditions of contract for the auction event.* In order to equip six functional departments and the computing center from *P* Power Plant with computers, the specialists in this field have established the necessary configuration and based upon offers from specialized companies they have drawn up a documentation regarding their main characteristics (price, delivery time, guarantee period, anti-shock proof, design, etc.). During the first phase of evaluating the offers there were ten companies specialized in selling computers; among these, only five were selected and they had to meet two compulsory criteria: the price of 42,500 Euros and the increase anti-shock proof. The data obtained following the analysis of the five offers, are presented in table no.1:

Table no. 1: Table centralizing the degree of meeting criteria

Performance criteria Suppliers	Price - euro - (C ₁)	Delivery time - days - (C ₂)	Guarantee -months - (C ₃)	Design (C ₄)	Reliability (C ₅)	Soft (C ₆)
S.C. Deck Electronic S.A. (V ₁)	31500	15	24	Nice	Very Good	Good
S.C. Ultra-Pro S.R.L. (V ₂)	30500	9	20	Satisfactory	Good	Satisfactory
S.C. Byte-Computer S.R.L. (V ₃)	32000	7	20	Nice	Good	Very Good
S.C. Info Trade-2001 S.R.L. (V ₄)	32500	3	18	Very nice	Very Good	Very Good
S.C. AMC Proiect S.R.L. (V ₅)	31750	12	20	Nice	Good	Good

The comparison criteria can be associated with grade scales if there are major differences among the criteria or the same grade scale can be applied in the case of every criterion if there are no important differences [34]. The most used grading system is between 0 ÷ 1, with a linear variation within these limits. In the grade book there are written all values corresponding to the criteria*. Thus, criteria 4, 5 and 6 are graded using numbers and they are presented in the initial decisional table (table no.2).

Table no. 2: The initial decisional table

C _i V _i	C ₁	C ₂	C ₃	C ₄	C ₅	C ₆
V ₁	31500	15	24	0,66	1	0,66
V ₂	30500	9	20	0,33	0,66	0,33
V ₃	32000	7	20	0,66	0,66	1
V ₄	32500	3	18	1	1	1
V ₅	31750	12	20	0,66	0,66	0,66
k _i	0,2500	0,0625	0,1875	0,0625	0,01875	0,2500

- *Determining the importance coefficients of the breaking criteria.* Evaluating the K_j coefficients can be done starting from the assessments of future beneficiaries and users who will establish the values for the coefficients starting from 1 for the least important criterion. Knowing these values, they can be transferred to normative K_j such as $0 \leq k_j \leq 1$ and $\sum k_j = 1$. After the specialist from P Power Plant have established the importance coefficients of the breaking criteria (K₁= 4, K₂= 1, K₃= 3, K₄= 1, K₅= 3, K₆= 4), they will be converted (according to the relation $k_j = \frac{K_i}{\sum_{i=1}^n K}$)

* The Grade Book has the role to mark each letter grade with a numerical grade such as: FB (Very Good) = 1, B (Good) = 0,66, S (Satisfactory) = 0,33 and NS (Not Satisfactory) = 0.

and there results the following: $k_1= 0.2500$, $k_2= 0.0625$, $k_3=0,1875$, $k_4= 0,0625$, $k_5= 0,1875$, $k_6= 0,2500$. these will be inserted in the last row of the initial decisional table;

- *Normalizing the consequences.* In order to ensure a homogenous quantitative assessment of the variants, the consequences are normalized by using a single variable referring to utility. The corresponding utilities of the consequences expressed in numbers are determined through linear interpolation based on the following relations:

$$a_{ij} = \frac{x_{ij} - \min_i x_{ij}}{\max_i x_{ij} - \min_i x_{ij}} \quad (1)$$

$$a_{ij} = \frac{\max_i x_{ij} - x_{ij}}{\max_i x_{ij} - \min_i x_{ij}} \quad (2)$$

where:

- a_{ij} – the utility of variant i , in criterion j ;
- x_{ij} – the consequence of variant i , in criterion j .

In the case where the optimum variant is the one that corresponds to the maximum value (the period of guarantee, the time of delivery for computers, their reliability, design, software) the relation no. (2) can be used, while in the case where the optimum variant is the one that corresponds to the minimum value (price, time of delivery), the relation which is used is (1).

Following these calculations that were made with the help of the software which makes decisions in conditions of certainty based on the Electre method presented in the appendix no. 1, the values of the normalized utilities are inserted in the table no. 3:

Table no. 3: The normalized utilities of the decisional problem

$V_i \backslash C_j$	C_1	C_2	C_3	C_4	C_5	C_6
V_1	0,500	0	1	0,49	1	0,49
V_2	1	0,50	0,33	0	0	0
V_3	0,250	0,66	0,33	0,49	0	1
V_4	0	1	0	1	1	1
V_5	0,375	0,25	0,33	0,49	0	0,49

- *Writing the concordance matrix.* The first breaking of the selected criteria can be done by establishing the concordance indexes with the help of the relation no. 3 and by making the concordance matrix $A = |\alpha_{kl}|$.

$$\alpha_{kl} = \frac{\sum_{j \in J_c} K_j}{\sum_j K_j} \quad kl=1, 2, \dots, m; \quad 0 \leq \alpha_{kl} \leq 1 \quad (3)$$

where:

- K_j – the importance coefficients of C_j criteria;

j_c – the concordance criteria index, and the criteria index which corresponds to the relation $(V_k P V_l)$.

Following the calculations performed with the help of the previous relation, the following concordance matrix can be written:

		Concordance matrix				
Variants	V ₁	V ₂	V ₃	V ₄	V ₅	
V ₁	-	0,688	0,688	0,625	0,938	
V ₂	0,313	-	0,625	0,438	0,688	
V ₃	0,375	0,750	-	0,688	0,750	
V ₄	0,563	0,563	0,563	-	0,563	
V ₅	0,375	0,688	0,688	0,438	-	

- *Writing the discordance matrix.* The discordance indicator β_{kl} is calculated in order to mark the priorities of variant V₁ compared to V_k, based on the following relation:

$$\beta_{kl} = \begin{cases} 0, (V_k P V_l), & a_{kj} \geq a_{lj} \text{ for all } C_j \text{ criteria} \\ \frac{1}{d} [\max(a_{ij} - a_{kj})], & (V_l P V_k), a_{lj} > a_{kj} \end{cases} \quad (4)$$

where:

a_{kj}, a_{lj} – the marks given to the variants V_k and V_l at criterion j;
d – the maximum value of all grading scales of the n criteria.

Following the calculations performed with the help of the relation no.4, the following discordance matrix can be written:

		Discordance matrix				
Variants	V ₁	V ₂	V ₃	V ₄	V ₅	
V ₁	-	0,5	0,66	1	0,25	
V ₂	1	-	1	1	0,49	
V ₃	1	0,75	-	1	0,125	
V ₄	1	1	0,33	-	0,375	
V ₅	1	0,625	0,51	1	-	

- *Drawing the priority graph of the compared products.* This graph is can be drawn with the help of an algorithm according to which the lower the discordance rate p (from p=1 to p=0) is, the higher the discordance rate q will be (q=0 to q=1). At the beginning of the variant separation process, the discrimination is set by the concordance between variants V_k and V_l, defined by the relation $(V_k P V_l)$. the algorithm shows that if the concordance cannot clarify the priority ratios between the variants during the separation process, then the discordance is being called for in order to increase the q indicator up to q=1, when the discordance decides upon a hierarchy of the variants. The evolution of the variant separation graph (table no. 4) shows that the separation process is iterative and it starts with the decisional degrees p=1 and q = 1 - p = 0. For each of the iterations the following relations must be identified based on the concordance and discordance matrixes $\alpha_{kl} \geq 1$ și $\beta_{kl} \leq 0$. The graph is finalized when there exist inputs and outputs in every V_i knot, that is to

say that in our case it continues up to the iteration 10 where there are 4 inputs and outputs in every knot; thus the graph can be closed.

Table no. 4: The evolution of the decisional variant separation graph

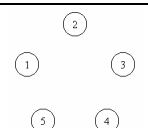
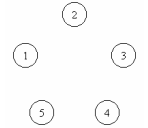
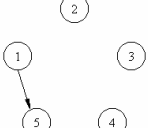
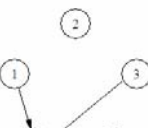
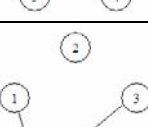
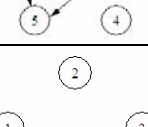
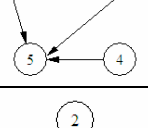
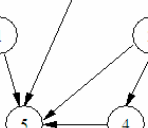
No. of iterations	Decision points p and q	The results of the analysis	Drawing the graph
1	p = 1 q = 0	No condition is verified, thus we move on to the next iteration	
2	p = 0,938 q = 0,062	No condition is verified, thus we move on to the next iteration	
3	p = 0,750 q = 0,250	V_{15}	
4	p = 0,688 q = 0,312	V_{15}, V_{35}	
5	p = 0,625 q = 0,375	$V_{15}, V_{35},$	
6	p = 0,563 q = 0,437	V_{15}, V_{35}, V_{45}	
7	p = 0,438 q = 0,562	$V_{15}, V_{35}, V_{45}, V_{25}, V_{34}$	
8	p = 0,375 q = 0,625	$V_{15}, V_{35}, V_{45}, V_{25}, V_{34}, V_{12}$	

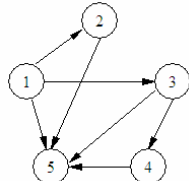
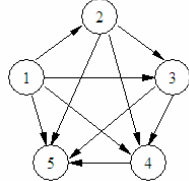
9	$p = 0,0313$ $q = 0,688$	$V_{15}, V_{35}, V_{45}, V_{25}, V_{34}, V_{12}, V_{13}$	
10	$p = 0$ $q = 1$	$V_{15}, V_{35}, V_{45}, V_{25}, V_{34}, V_{12}, V_{13}, V_{14},$ V_{23}, V_{24}	

Because the priority graph ends with the tenth iteration, we can write the following variant preference relation ($V_1 P V_4 P V_3 P V_2 P V_5$). The optimum variant is V_1 , that is to say the offer from S.C. Deck Electronic S.A which, according to the graph, generates four arches, while the weakest variant is V_5 , meaning the offer from S.C. Info Trade 2001 S.R.L., since the graph indicates four inputs. In between the two variants there come, in turns, variant V_2 with one input and three outputs, variant V_3 with two inputs and two outputs and variant V_4 with three inputs and one output.

Another problem faced by P Power Plant is making decisions when the situation is incompletely defined and the environment conditions are unpredictable. It is necessary to optimize the decisions in conditions of uncertainty, decisions which are specific, mainly, to the superior management that makes complex decisions with multiple and profound implications upon the existence of the company. Therefore, it is important to know and operate such methods at all superior management levels and the components of the participating organisms, which represents a guarantee in ensuring the high quality of the group decisional process.

One of the decisional situations in conditions of uncertainty, which is characteristic for the thermoelectric power plants, is the increase, the reduction or the canceling of the production of thermal energy, considering the energetic inefficiency owing mainly to the use of old, out-dated equipment and the outworn installations that increase production costs and the price of thermal energy delivery, implicitly more than urban and industrial consumers can afford, even if they are offered grants. The costs of energy production are very high and therefore, in the case of little income there is a lack of financial resources for reparations and renovation. The same thing happens at P Power Plant as well, and thus the management team together with the specialists from S.C. Termoelectrica S.A., S.C. ISPE S.A. and S.C. ICEMENERG S.A., have forwarded for analysis the following variants regarding the future evolution of the energy production: building a new plant which produces both electricity and thermal energy at the same time; modernizing the existing co-generation plants; maintaining the present situation; closing down an energetic station. These variants are dependent upon the fluctuations of energy demands both from home consumers and industrial consumers within X municipality. The consequences of each option have been estimated to amount to thousands of dollars (table no. 5).

Table no. 5: Presenting the decisional variants and situations within P Power Plant in conditions of fluctuating thermal energy

Decisional situations Variants		Increasing demand	Decreasing demand	Constant demand	Insignificant demand
		S ₁	S ₂	S ₃	S ₄
V ₁	Building a plant	39	0	6	-22
V ₂	Closing down a plant	18	23	16	-5
V ₃	Modernizing the existing plants	29	7	12	-9
V ₄	Maintaining the present situation	23	4	9	-7

In order to make a decision under the circumstances, several decision optimizing methods and techniques have been used in conditions of uncertainty, such as [24]:

- **the pessimist technique** or the pessimist criterion established by Abraham Wald, who considers that the best option is the one that presents maximum advantages when the objective conditions are unfavorable. Optimizing decisions with the help of this technique can be done through the following relation:

$$V_{\text{optimum}} = \max_i \min_j (V_i, C_j) \quad (5)$$

where :

V_i – the decisional variant;

C_j – the objective state. .

According to the data presented in table no. 5 and to the previous equation, we can write $\max\{-22; -5; -9; -7\} = -5$ thus, the best option determined by the pessimist criterion is the second one, that is to say the closing down of the plant which registers the highest energy production costs;

- **the optimist technique** or the optimist criterion which chooses the best option when the objective conditions are most favorable, according to the maximax rule from the following relation:

$$V_{\text{optimum}} = \max_i \max_j (V_i, C_j) \quad (6)$$

According to the data from table no. 5 and to the relation 6, $\max\{39; 23; 29; 23\} = 39$ thus, the optimum variant which was determined using the optimist criterion is the first option, that is to say building a new co-generation plant, the technical performances of which will substantially reduce energy production costs, even in the situation where there must be spend quite a lot of money with the equipment amortization;

- **the optimal technique of Hurwicz** or the constant optimist criterion which puts into balance the consequences of the pessimist and optimist techniques. Thus, a constant value is obtained for each action option according to the following formula:

$$H_i = \alpha \max_j (a_{ij}) + (1 - \alpha) \min_j (a_{ij}) \quad (7)$$

where:

α - the optimism coefficient of the decider ($0 \leq \alpha \leq 1$).

The best option will correspond to the variant that has the greatest H_i value.

$$V_{\text{optimum}} = \max_i H_i \quad (8)$$

Analyzing the results from an Excel sheet (see appendix no.2) and the optimum variants determined with the help of Hurwicz's optimal technique, considering the different values of the optimism coefficient presented in the appendix no.3, we can notice that for values between $0 \leq \alpha \leq 0,3$ the best option is the second one and it is the result of implementing the pessimist criterion (for $\alpha = 0$, the constant optimism criterion changes into the pessimist criterion), while in the case of optimism coefficients with values of $0,6 \leq \alpha \leq 1$ the best variant is the one that corresponds to the optimist criterion, that is to say the first variant (for $\alpha = 1$, the constant optimism criterion changes into the optimist criterion). If we admit a medium value for the optimism degree and if we consider $\alpha = 0,5$, then we can notice that the third variant is the best one, that is to say the variant which refers to modernizing the existing energetic plants;

- **the proportional technique** or Laplace criterion is based upon Bernoulli's postulate and it says that if we have a certain sequence of events, we cannot state that one of them is more likely to occur than the others, therefore they are all equally probable. Starting from the premise that all the objective conditions have the same probability of occurrence, according to the relation 9, for each variant the mathematic expectation of the variants must be determined; the optimum variant which results from this is the one that satisfies the condition presented in the following calculations:

$$E_i = \frac{1}{n} \sum_j a_{ij} \quad (9)$$

E_i – the mathematic expectation for variant i .

$$V_{\text{optimum}_i} = \max \{E_i\} = \max_i \left\{ \frac{1}{n} \sum_j a_{ij} \right\} \quad (10)$$

In the case presented above, implementing Laplace criterion can be done with the help of Microsoft Excel which will determine us to choose the second variant, meaning to close down a co-generation energetic group, according to the following condition:

$$\max_i \{5,75; 13; 9,75; 7,25\} = 13 ;$$

- **the technique of minimizing regrets** or the minimax regret criterion has a “clear psychological significance” due to the regret matrix which was established previously. Regrets are defined as opportunity loses which occur when the best variant is not the one chosen, for each state of nature. L. Savage has stated that in the case when this criterion is used, the decider tends to choose the variant which will minimize the greatest anticipated regret. This technique implies, in the first place, determining the regret matrix where each element is obtained by detracting the maximum element in

the column from the initial value, then secondly, the maximum values of the regrets are determined, according to the following calculations:

$$R_{ij} = a_{ij} - \max_i(a_{ij}) \quad (11)$$

R_{ij} – the regret of alternative i in the state of nature j;

a_{ij} - variant i in the condition of the state of nature j.

The regret matrix obtained with the help of the data from table no. 5 is realized with Microsoft Excel just like in the appendix no.2; by applying the condition $\min_i \max_j(R_{ij})$ to this matrix, we get the optimum variant which chooses among the following values:

$$\min_i = \{ 23, 21, 16, 19 \}$$

Thus, the minimax regret criterion pleads for the adoption of the third variant, meaning the modernization of energetic groups.

The centralization of the optimum decisional variants is presented in the following table no. 6:

Table no. 6: Centralizing the optimum decisional variants

	The pessimist criterion	The optimist criterion	The optimal technique	The proportional technique	The technique of minimizing regrets
Building a group (V ₁)					
Closing down a group (V ₂)					
Modernizing existing groups (V ₃)					
Maintaining the present situation (V ₄)					

Taking into consideration the colored areas in the table, we can notice that the fourth variant regarding the maintaining the present situation of the energetic groups, does not satisfy any of the calculus procedure; therefore it will be eliminated in this phase. In the next phase, another problem arises, that of choosing among V₁, V₂ and V₃. Since the rule of the majority is not relevant in this case, the second and the third variant which are both colored twice cannot be considered preferable in comparison with the first variant which has only one colored square. As a consequence, in the case of decisional variants in conditions of uncertainty, the risk cannot be totally eliminated but it can be reduced. In this respect, the specialized literature recommends the implementation of the first variant according to one of the following problems [34]: problems which lead to catastrophic consequences for the deciders when the most unfavorable situation occurs and problems which have no catastrophic consequences when an unfavorable situation occurs.

If in conditions of uncertainty, the first variant is likely to occur and this has no catastrophic effects upon the activity within the power plant, according to the optimist variant, this is one variant that will be chosen, that is to say the building a new co-generating energetic group because it brings the greatest profit in case the demand for thermal energy increases.

In order to use one of the optimizing techniques, we must take into consideration both the habit of the decider to use a certain technique, the manager's psychology and the company's economic-financial state. The better the company's economic-financial state is, the more likely it is to take greater risks, which means having optimistic visions about the probability to obtain better results.

During the decisional process there can be cases when managers cannot eliminate the risks completely due to the complexity of the situation; this happens in case random phenomena occur. There are risks when the decider does not anticipate the result which is characteristic to a decision, but he is able to establish an objective probability distribution of the possible states of nature and of their costs. Situations with a certain degree of risk can be classified into pure and speculative situations [21]. The pure risk exists when there is the chance for the decider to witness a loss upon the implementation of the decision, without any chance to succeed. The speculative risk exists when there is both the possibility to lose and to win at the same time. Therefore, the manager must perform a probable decisional evaluation and selection analysis. Allowing for the great percentage of risk which accompanies the activity of the management within the energetic industry, there is the frequent need to make decisions under risky conditions using the decisional tree method.

The decisional tree method facilitates the analysis of potential results of a complex decision regarding future events that can influence it, determining a set of values referring to the results for each decisional alternative [32]. The frequent use of this method is due to the fundamental results it offers during the strategic decisional process, through the possibility of analyzing the parameters which condition a certain decisional situation and last but not least through its simple visual aspect.

The most significant elements which characterize the decisional tree are: the existence of a decisional situation which implies a variable number of decision knots, of event knots and final results; the existence of a complex strategic economic situation and of some clear reference criteria which are accurately formulated; the probable estimation of the consequences of each decisional option; the possibility to determine the results of one or of the other variant which offers the opportunity to study some complex decisional problems over a long period of time; the possibility to find the best result through a comparative analysis of the variants starting from the right and gradually moving towards the base (the roll-back procedure).

At *P* Power Plant, one of the energetic groups (the energetic group which has a maximum available power of 150 MW) presents a high level of weariness because of the extended functioning period; that is why the management team proposed to take care of the problem either by repairing or modernizing this group, or by investing in a new power station. Regardless of the option that is chosen, the objectives established by the management team refer to the following: increasing time and energy availability, improving technical-economic parameters, introducing new automated control systems, reducing the quantity of polluting emissions and obeying the environment regulations etc. Taking into consideration these objectives, the management team from *P* Power Plant, analyzed the following possible options (table no. 7):

Table no. 7: The variables of the decisional tree parameters

Separation points of the options	Vk _i variants	Invested efforts per variant		States of nature		Probabilities of the states of nature		Income* (+) Expenditure** (-)	
		Code	Mil.\$	Code	Specifications	Code	Values	Code	Mil.\$/an
1	V ₁₁ Capital renovation works	I ₁₁	34,5	S ₁₁₁	There are financial resources	P(S ₁₁₁)	0,90	C ₁₁₁	42,5
				S ₁₁₂	There are no financial resources	P(S ₁₁₂)	0,10	C ₁₁₂	-0,1
	V ₁₂ Modernizing the power plant	I ₁₂	72,25	S ₁₂₁	There are financial resources	P(S ₁₂₁)	0,60	C ₁₂₁	125
				S ₁₂₂	There are no financial resources	P(S ₁₂₂)	0,40	C ₁₂₂	-0,1
	V ₁₃ Setting up a new power plant	I ₁₃	196,2	S ₁₃₁	There are financial resources	P(S ₁₃₁)	0,25	C ₁₃₁	240
				S ₁₃₂	There are no financial resources	P(S ₁₃₂)	0,75	C ₁₃₂	-0,1
2	V ₂₁ Aborting the exploitation of the power plant and recovering/capitalizing on the spare parts	I ₂₁	0	S ₂₁₂	There are no financial resources	P(S ₂₁₂)	0,10	C ₂₁₂	-5
3	V ₃₁ Modernization without setting up a sweetening station	I ₃₁	68,3	S ₃₁₁	There are financial resources	P(S ₃₁₁)	0,65	C ₃₁₁	135
				S ₃₁₂	There are no financial resources	P(S ₃₁₂)	0,35	C ₃₁₂	-0,1
	V ₃₂ Modernization with a sweetening station	I ₃₂	96,2	S ₃₂₁	There are financial resources	P(S ₃₂₁)	0,55	C ₃₂₁	73,6
				S ₃₂₂	There are no financial resources	P(S ₃₂₂)	0,45	C ₃₂₂	-0,1

* The income was estimated considering the following elements: extending the functioning period of the power plant, the maximum available power, the medium supplied production, the number of hours of functioning per year, the cost, the medium sales price of electricity during the last year.

** The expenses were equalled with the difference between the revenues due to delivering the electricity produced by this plant and the corresponding costs of producing electricity, meaning the loss of the exploitation activity within this plant. At decisional knot 2, they summed up the value of costs necessary for deallocation, dissembling and demolishing the building, after the possible income obtained from materializing the spare parts and metal waste had been taken out.

4	V ₄₁ Setting up a new power plant within the existent one	I ₄₁	211,3	S ₄₁₁	There are financial resources	P(S ₄₁₁)	0,20	C ₄₁₁	260
				S ₄₁₂	There are no financial resources	P(S ₄₁₂)	0,80	C ₄₁₂	-1,8
	V ₄₂ Building a new power plant by demolishing the existent one	I ₄₂	181,2	S ₄₂₁	There are financial resources	P(S ₄₂₁)	0,15	C ₄₂₁	240
				S ₄₂₂	There are no financial resources	P(S ₄₂₂)	0,85	C ₄₂₂	-1,8

- V₁- capital renovation works according to prescriptions. If these reparations were made, the functioning period of this plant will be extended by 48000 hours; that means eight years on condition is kept operational 6000 hours/year, with only one reparation work that can be recovered from ulterior profit (the income can be estimated at 42,5 mil \$, if the medium sales price of electricity is 60\$/MWh). According to this option, the parameters of the polluting sulphur dioxides, nitric oxides and ash powder emissions remain high, but considering the present lack of financial resources, this option is likely to be chosen by managers although from the point of view of environment standards, this option is not viable;
- V₂ – modernizing the power plant by obtaining a nominal capacity of the boilers which is more than 87%, a specific raw consumption of 2225 kcal/kWh per plant and extending the working hours by 96000 hours. This modernization is possible if two options are used: the one which includes a sweetening station or the one without a sweetening station; the role of this station is to reduce sulphur dioxide emissions from 4790 mg/Nmc to 200 mg/Nmc. The period of time necessary for this investment is 2 years and it implies costs of 68.3 mil.\$ in the case of renovating the plant without setting up this sweetening station and 3 years in the case of renovating by making this station work; the value of the investment is, in this case 96,2 mil. \$;
- V₃ – building a new power plant with a generating station capacity which is equivalent with the existing one represents a radical solution and it can be implemented by demolishing the existing plant or by extending it, which would reduce the value of the initial costs and the investment period by 2 months; this operation is to be carried out after the new power plant has been put into service. Taking into consideration the environment protection rules, the new power plant will function according to the parameters required by the regulations regarding the quantity of polluting emissions (sulphur dioxides will be reduced to 150-200 mg/Nmc, compared to approximately 4800 mg/Nmc registered at the current installation, ash powders will be reduced by 7-8 times, while nitrogen oxide is practically eliminated); these regulations are compulsory up to the finalization of the investment and the internal legislation must fall into line with the European legislation.

Preparing the informational support which is needed to solve the mentioned decisional tree, implies mentioning the following aspects:

- *Evaluating the investments and the results* for the implementation of the variants implies expertise operations or the elaboration of some feasibility studies. While feasibility studies perform a more accurate evaluation of the investment because they are based upon project sketches and expenditure estimates, an expertise refers to an estimation of the invested efforts made by experts, based on previous experiments, without doing any calculations in this respect. The results, the income and the expenditure respectively, can be calculated by consulting a price catalogue, the offers coming from companies producing energetic equipment, the price list of the utilities and services and the costs estimated by research institutes in the energetic field. When analyzing the opportunity to modernize *P* Power Plant, the value of the investments and the results were forecasted based on financial expertise made by specialist from the Institute of Energetic Design and Research from Bucharest in their pre-feasibility studies regarding the re-equipment of power plants;
- *Determining the probability of occurrence of the states of nature* can be done either through the conditioned probability method or through the simple probability method. Conditioned probabilities are dependent on the Bayes theorem which uses two types of probabilities – anterior and posterior. Simple probabilities can be determined objectively and they can be applied in the case of repetitive processes based on statistics, while subjective probabilities are established by experts indicating the level of probabilities during a period of time when this level proves an even distribution [34]. In the present example, the probabilities of occurrence of the states of nature have been estimated by financial-accounting experts from *P* Power Plant and from S.C. Termoelectrica S.A.

The decisional tree based on the three main variants is graphically represented as an open graph in the no. 4. In order to solve this decisional tree, one must analyze the progress of the operation sequence in the long run, operations that are part of the decisional alternatives shown in the appendix no. 5.

Solving the decisional tree can be done by applying the “roll-back” procedure from starting from the last decisional point and calculating the mathematic expectations in order to choose the optimum variants in the decisional points, according to the following relation:

$$E(V_{ki}) = \sum_{j=i}^n p_{kij} \times \sum_{t=t_k}^T \frac{c_{kij}(t)}{(1+d)^t} - \frac{i_{ki}}{(1+d)^{t_k}} \quad (12)$$

where:

i_{ki} – the necessary efforts invested for the implementation of variant “*i*” of the D_k knot;
 t_k - the number of the decisional point;
 d - the update ratio.

The “roll-back” analysis starts from the last decisional point and carries out as follows [25]:

- *Decisional point 4.* The mathematic expectations of the two variants V_{41} and V_{42} based on the relation 12:

$$E(V_{41}) = p(S_{411}) \sum_{t=5}^{12} \frac{c_{411}(t)}{(1+d)^t} + p(S_{412}) \sum_{t=5}^{12} \frac{c_{412}(t)}{(1+d)^t} - \frac{I}{(1+d)^T} = 98,80 \text{ mil.}\$$$

$$E(V_{42}) = p(S_{421}) \sum_{t=5}^{12} \frac{c_{421}(t)}{(1+d)^t} + p(S_{422}) \sum_{t=5}^{12} \frac{c_{422}(t)}{(1+d)^t} - \frac{I}{(1+d)^T} = 75,07 \text{ mil.}\$$$

The optimum solution in this decisional point is the one that satisfies the condition: $\max\{E(V_{41}); E(V_{42})\} = \max\{98,80; 75,07\} = 98,80 \Rightarrow V_{\text{opt}}^* = V_{41}$, that is to say the variant of setting up a new power plant within the existing one.

- *Decisional point 3.* The mathematic expectations of the two variants V_{31} and V_{32} are calculated based on the relation 12:

$$E(V_{31}) = p(S_{311}) \sum_{t=3}^8 \frac{c_{311}(t)}{(1+d)^t} + p(S_{311}) \sum_{t=10}^{12} \frac{c_{311}(t)}{(1+d)^t} + p(S_{312}) \sum_{t=3}^8 \frac{c_{312}(t)}{(1+d)^t} + p(S_{312}) \sum_{t=10}^{12} \frac{c_{312}(t)}{(1+d)^t} - \frac{I_1}{(1+d)^{T_1}} - \frac{I_2}{(1+d)^{T_2}} = 293,99 \text{ mil.}\$$$

$$E(V_{32}) = p(S_{321}) \sum_{t=3}^8 \frac{c_{321}(t)}{(1+d)^t} + p(S_{321}) \sum_{t=10}^{12} \frac{c_{321}(t)}{(1+d)^t} + p(S_{322}) \sum_{t=3}^8 \frac{c_{322}(t)}{(1+d)^t} + p(S_{322}) \sum_{t=10}^{12} \frac{c_{322}(t)}{(1+d)^t} - \frac{I_1}{(1+d)^{T_1}} - \frac{I_2}{(1+d)^{T_2}} = 193,46 \text{ mil.}\$$$

The optimum solution in this decisional point is the one that satisfies the condition: $\max\{E(V_{31}); E(V_{32})\} = \max\{293,99; 193,46\} = 293,99 \Rightarrow V_{\text{opt}}^* = V_{31}$, that is to say the option to modernize the power plant without a sweetening station.

- *Decisional point 2.* Even if it does not require calculations because stopping the exploitation of the power plant is the only available alternative in that certain situation, we can determine the mathematic expectation for a correct evaluation of the alternatives in other decisional points.

$$E(V_{21}) = p(S_{212}) \frac{c_{212}(t)}{(1+d)^t} - \frac{i_{21}}{(1+d)^t} = -0,087 \text{ mil.}\$$$

- *Decisional point 1.* The mathematic expectations of the three variants V_{11} , V_{12} and V_{13} are calculated based on the relation 12:

$$E(V_{11}) = p(S_{111}) \sum_{t=2}^4 \frac{c_{111}(t)}{(1+d)^t} + p(S_{111}) \sum_{t=7}^{12} \frac{c_{111}(t)}{(1+d)^t} + p(S_{112}) \sum_{t=2}^4 \frac{c_{112}(t)}{(1+d)^t} + p(S_{112}) \sum_{t=7}^{12} \frac{c_{112}(t)}{(1+d)^t} - \frac{I_1}{(1+d)^{T_1}} - \frac{I_2}{(1+d)^{T_2}} = 110,45 \text{ mil.}\$$$

$$E(V_{12}) = p(S_{121}) \sum_{t=3}^8 \frac{c_{121}(t)}{(1+d)^t} + p(S_{121}) \sum_{t=10}^{12} \frac{c_{121}(t)}{(1+d)^t} + p(S_{122}) \sum_{t=3}^8 \frac{c_{122}(t)}{(1+d)^t} + p(S_{122}) \sum_{t=10}^{12} \frac{c_{122}(t)}{(1+d)^t} - \frac{I_1}{(1+d)^{T_1}} - \frac{I_2}{(1+d)^{T_2}} = 245,33 \text{ mil.}\$$$

$$E(V_{13}) = p(S_{131}) \sum_{t=5}^{12} \frac{c_{131}(t)}{(1+d)^t} + p(S_{132}) \sum_{t=5}^{12} \frac{c_{132}(t)}{(1+d)^t} - \frac{I}{(1+d)^T} = 123,87 \text{ mil.}\$$$

The optimum solution for the decisional point 1 is the one that satisfies the condition: $\max\{E(V_{11}); E(V_{12}); E(V_{13})\} = \max\{110,45; 245,33; 123,87\} = 245,33 \Rightarrow V_{\text{opt}}^* = V_{12}$, that is to say the existent power plant modernization variant.

In conclusion, the decision regarding future activities of the power plant corresponds to the following alternative sequence $(V_{31}^*; V_{12}^*; V_{41}^*)$, meaning that for the time being it is recommendable that the option to modernize the power plant without a sweetening station should be applied; then, in the future this power plant will be abandoned and it will be replaced by a new one.

BIBLIOGRAPHY

- [1] Anderson D., Turvey R. – *Electricity Economics. Essays and Case Studies*. Published for the World Bank, The Johns Hopkins University Press, Baltimore Maryland, U.S.A., 1999
- [2] Andreica M., Stoica M., Luban F., *Quantitative Methods in Management*, Economic Pb. House, Bucharest, 1998
- [3] Barabas I., Brânzan P., Someșan C., *Modern Methods in Management and Marketing*, Sincron Pb. House, Bucharest, 1997
- [4] Băcanu B., *Strategic Management*, Teora Pb. House, Bucharest, 1997
- [5] Bărbulescu C., *The Company's Strategic Systems*, Economic Pb. House, Bucharest, 1999
- [6] Bărbulescu C., *Efficient Management of the Company*, Economic Pb. House, Bucharest, 2000
- [7] Bâgu C., Deac V., *The Strategy of the Company*, Expert Pb. House, Bucharest, 2000
- [8] Boissy P., *Developpement international. La choix des strategies*, Les Editions d'organization, Paris, 1989
- [9] Burduș E., Căprărescu Gh., Androniceanu A., *The Organizational Change Management*, Economic Pb. House, Bucharest, 2000
- [10] Bușe G. – *Complete Dictionary of Market Economy*, Societatea Informația Publishing House, Bucharest, 1994
- [11] Ciobanu I., *Strategic Management*,. Polirom Pb. House, Iași, 1998
- [12] Demetrescu M. C., *Methods of Analysis in Marketing*, Teora Pb. House, Bucharest, 2000
- [13] Dinu E., *The Strategy of the Company*, Economic Pb. House, Bucharest, 2000
- [14] Florescu C. (coord.), *Marketing*, Academic Group of Marketing and Management, Bucharest, 1992
- [15] Grove A. - *Le management multiplicateur*, Edition Hommes et Techniques, Paris, 1985
- [16] Hax A., Majluf N., *Strategic Management. An Interactive Perspective*, Ed. Pertnice Hall, Englewood Cliffs, 1994
- [17] Ionescu Gh., Cazan E., Negruță A., *Modeling and Optimizing Managerial Decisions*, Dacia Pb. House, Cluj-Napoca, 1999
- [18] Johansson H. ș.a. – *Business Process Reengineering, Breakpoint Strategy for market Dominance*, Chichester, 1993
- [19] Lamb R. B., *Competitive Strategic Management*, Ed. Pretince Hall, Englewood Cliffs, 1984
- [20] Kickert W. – *Organization of Decision – Making. A system Approach*, North-Holland Publishing Company, Amsterdam, 1980
- [21] Mărăcine V.– *Managerial Decisions. Improving Decisional Performances of the Company*, Economic Publishing House, Bucharest, 1999
- [22] Mitran I. – *Elements of optimization theory and mathematic modeling of the decisional procedures*, Universitas Publishing House, Petroșani, 2001

- [23] Nicolescu O., *Guide of the Efficient Manager vol. I and II*, Technical Pb. House, Bucharest, 1993
- [24] Nicolescu O., Verboncu I. – *Management*, Economic Publishing House, Buharest, 1995
- [25] Nicolescu O., *Managerial Systems, Methods and Techniques of the Organisation*, Economic Publishing House, Bucharest, 2001
- [26] Pârvu F., *Decision Costs and Fundaments*, Economic Pb. House, Bucharest, 1999
- [27] Popescu I.A. – *Theory and Practice in the Analysis of Management Systems*, volume III, Scrisul Românesc Publishing House, Craiova, 1986
- [28] Purcaru I. – *General Mathematics and Optimization Elements. Theory and Applications*, Economic Publishing House, Bucharest, 1998
- [29] Quinn J. B., *Strategies for change: logical incrementalism*, Homewood Richard D. Irvin, Boston, 1980
- [30] Rațiu-Suciu C., *Applied Economic Modeling*, Economic Publishing House, Bucharest, 2002
- [31] Rusu E., *Optimal Decision in Management through Operational Research Methods. Problems and Case Studies*, Economic Publishing House, Bucharest, 2001
- [32] Russu C. – *Management*, Expert Publishing House, Bucharest, 1996
- [33] Spitezki H., *La strategie d'entreprise: completitivité et mobilité*, Ed. Economica, Paris, 1994
- [34] Stăncioiu I., Militaru Gh., *Management. Fundamental Elements*, Teora Pb. House, Bucharest, 1998
- [35] Zorlențan T., Burduș G., Căprărescu Gh., *The Organization Management*, Economic Pb. House, Bucharest, 1999

Information Programme for Determining the Optimal Decision in Conditions of Certainty Based on the Electre Method

```

program electre;
type fisier=file ;
var i,j,j1,j2,M,N,test:integer;
    r1,r2,rm:longint;
    p,q,aux:real;
    K,elem_C:array [1..20] of real;
    A,C,D:array [1..10,1..10] of real;
    R:array [1..10000,1..2] of integer;
    f:text;
begin
write('Introduceti nr de linii M=');readln(M);
write('Introduceti nr de coloane N=');readln(N);

assign(f,'date_ele.dat');
reset(f);
for i:=1 to M do
  for j:=1 to N do
    begin
      {write('A(',i,',',j,')=');} readln(f,A[i,j])
    end;
for j:=1 to N do
  begin
    {write('K(',j,')=');} readln(f,K[j])
  end;
close(f);
writeln ('Matricea initiala este:');
for i:=1 to M do
  begin
    for j:=1 to N do
      write(A[i,j]:4:3,' ');
    writeln
  end;
readln;
for i:=1 to M do
  for j:=1 to N do
    if i=j then C[i,j]:=-1
    else
      begin
        C[i,j]:=0;
        for j1:=1 to N do
          if A[i,j1]>=A[j,j1] then C[i,j]:=C[i,j]+K[j1]
        end;
writeln ('Matricea de concordanta este:');
for i:=1 to M do
  begin
    for j:=1 to M do
      write(C[i,j]:4:3,' ');
    writeln
  end;
writeln;

{Transferul elementelor matricii de concordanta intr-un vector}

j1:=2; elem_C[2]:=C[1,2]; elem_C[1]:=0;

```

```

for i:=1 to M do
  for j:=1 to M do
    if i<>j then
      begin
        test:=1;
        for j2:=2 to j1 do
          begin
            {write('e=',elem_C[j2]:4:3,' C=',C[i,j]:4:3,' j1=',j1,' ');}

            if elem_C[j2]<>C[i,j] then test:=test+1 ;
          end;
        if test=j1 then
          begin
            j1:=j1+1;
            elem_C[j1]:=C[i,j]
          end;
        {writeln;}
      end;
{Ordonarea elementelor matricii de concordanta}
test:=1;
while test=1 do
  begin
    test:=0;
    for j:=2 to j1-1 do
      if elem_C[j]>elem_C[j+1] then
        begin
          aux:=elem_C[j]; elem_C[j]:=elem_C[j+1]; elem_C[j+1]:=aux;
          test:=1
        end;
    end;

    {Tiparirea elementelor matricii de concordanta}
    writeln('Elementele matricii de concordata ordonate sunt :');
    for j:=2 to j1 do write(elem_C[j]:4:3,' ');
    writeln;
    readln;
    j1:=j1+1; elem_C[j1]:=1;

for i:=1 to M do
  for j:=1 to M do
    if i=j then D[i,j]:=-1
    else
      begin
        D[i,j]:=0;
        for j2:=1 to N do
          if A[j,j2]>A[i,j2] then
            if D[i,j]<(A[j,j2]-A[i,j2]) then D[i,j]:=A[j,j2]-
A[i,j2];
          end;
        writeln ('Matricea de discordanta este:');
for i:=1 to M do
  begin
    for j:=1 to M do
      write(D[i,j]:4:3,' ');
    writeln
  end;
end;

```

```

writeln('Continuati calculul grafului?');readln;
writeln('j1=',j1);

r1:=1;
for j2:=j1 downto 1 do
begin
r2:=r1;
p:=elem_C[j2]; q:=1-p;
writeln('Iterația nr. ',j1-j2+1,' p=',p:4:3,' q=',q:4:3);
for i:=1 to M do
for j:=1 to M do
if (C[i,j]>=p) and (D[i,j]<=q) then
begin
R[r1,1]:=i; R[r1,2]:=j;
r1:=r1+1;
r2:=r2+1
end;
for i:=1 to r2-1 do
writeln(R[i,1],' -> ',R[i,2]);
readln;
end;

rm:=r1-1;
writeln ('rm:=',rm); readln;

for r1:=1 to rm do
for r2:=r1+1 to rm do
begin
if (R[r1,1]=R[r2,1]) and (R[r1,2]=R[r2,2]) then
begin
R[r2,1]:=0; R[r2,2]:=0
end;
if (R[r1,1]=R[r2,2]) and (R[r1,2]=R[r2,1]) then
begin
R[r2,1]:=0; R[r2,2]:=0
end;
end;
readln;
writeln('Rezultatele sunt:');
for r1:=1 to rm do
if (R[r1,1]<>0) and (R[r1,2]<>0) then writeln(R[r1,1],' -> ',R[r1,2]);
writeln ('Sfarsit');
readln

end.

```

Excel Sheet for Decisions' Optimization in Conditions of Certainty

	A	B	C	D	E	F	G	H	I	J	K	L	M	N	O	
1																
2																
3			39	0	6	-22										
4			18	23	16	-5										
5			29	7	12	-9										
6			23	4	9	-7										
7																
8		The Pessimist Technique	max min a						2							
9			-22	-5	-9	-7		2								
10																
11		The Optimist Technique	max max a						1							
12			39	23	29	23		1								
13																
14		The Optimal Technique of Hurwicz														
15								3								
16			8,5	9	10	8		3								
17																
18			0	23	10	17										
19			21	0	0	0										
20			10	16	4	4										
21			16	19	7	2										
22																
23		The Technique of Minmax Regrets														
24			min max r				16		3							
25			23	21	16	19		3								
26																
27		The Laplace Technique														
28			max medium						2							
29			5,75	13	9,75	7,25		2								
30																
31																
32																
33																
34																
35																
36																



**Determination of Optimum Variants Using Hurwicz's Optimal Technique
Considering the Cases of Different Values of the Optimism Coefficient**

Optimism Coefficient	V_1	V_2	V_3	V_4	$V_{\text{optimă}}$
0	-22	-5	-9	-7	2
0,1	-22	-5	-9	-7	2
0,2	-9,8	0,6	-1,4	-1	2
0,3	-3,7	3,4	2,4	2	2
0,4	2,4	6,2	6,2	5	3
0,5	8,9	9	10	8	3
0,6	14,6	11,8	13,8	11	1
0,7	20,7	14,6	17,6	14	1
0,8	26,8	17,4	21,4	17	1
0,9	32,9	20,2	25,2	20	1
1	39	23	29	23	1

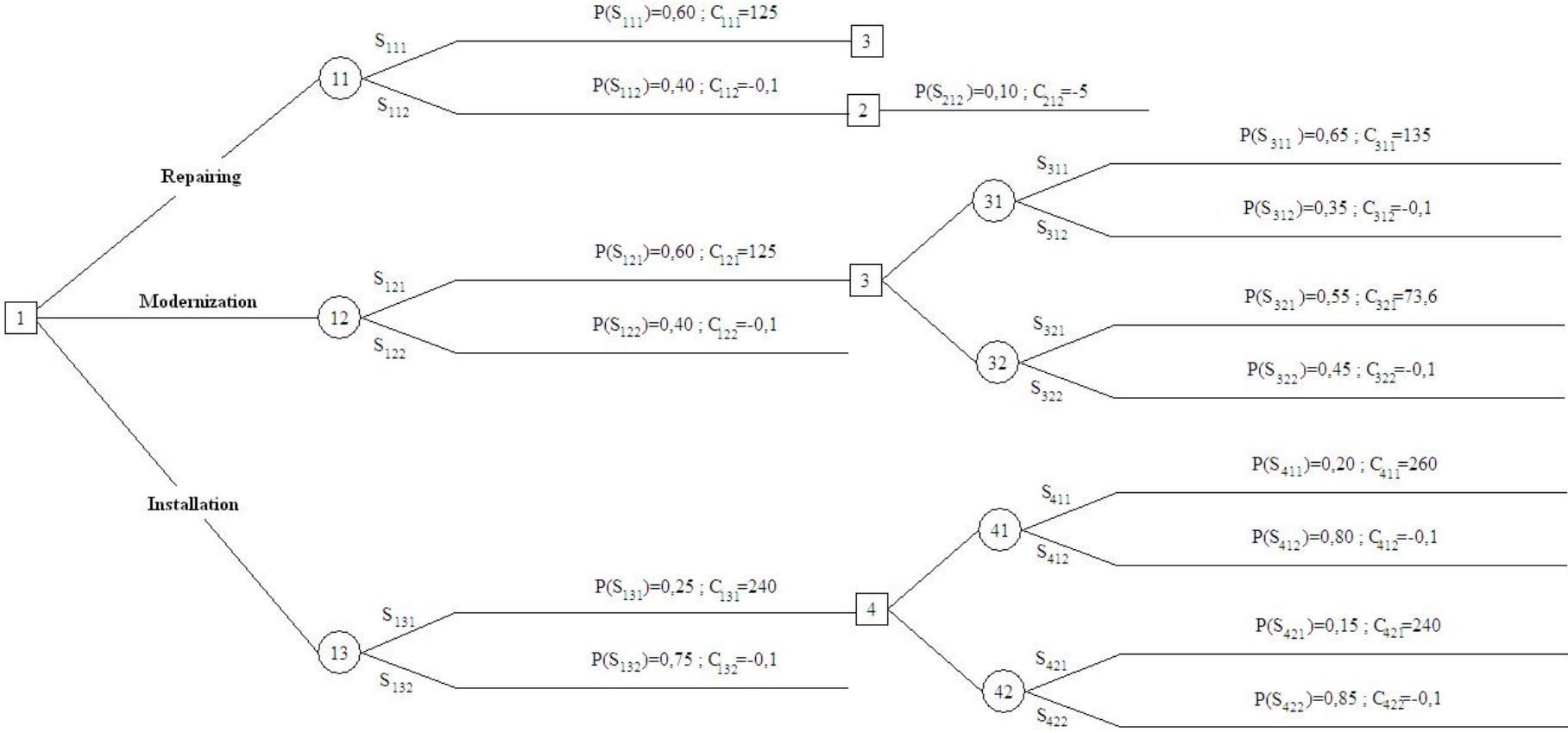
The Decisional Tree

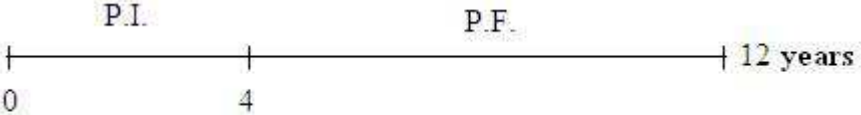

Spacing Out the Variants of the Decisional Tree

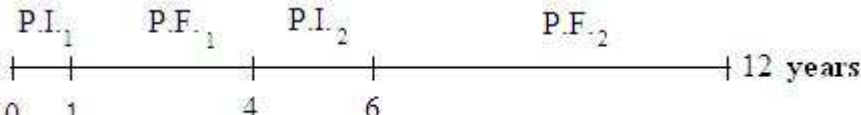
Decisional Variants	Time Echelons	Observations
Building a new power plant		<p>The total period of 12 years is divided as it follows:</p> <p>PI – investment carrying on period (4 years);</p> <p>PF – continuous functioning period (8 years).</p>
Modernizing the power plant		<p>The total period of 12 years is divided as it follows:</p> <p>PI₁,PI₂ – modernizing investment carrying on period (2 years), respectively the capital renovation investment duration (1 year);</p> <p>PF₁,PF₂ – periods of continuous functioning after modernization (6 years), respectively after capital renovation (3 years).</p>
Capital Renovation Works		<p>The total period of 12 years is divided as it follows:</p> <p>PI₁,PI₂ – periods of investment carrying on related to the capital renovation (1 year) and to modernization (2 years);</p> <p>PF₁,PF₂ – periods of continuous functioning after capital renovation (3 years) and after modernization (6 years).</p>