



Munich Personal RePEc Archive

Food Security Modelling

Kuzmin, Evgeny

Ural State University of Economics

September 2015

Online at <https://mpra.ub.uni-muenchen.de/67029/>

MPRA Paper No. 67029, posted 03 Oct 2015 06:00 UTC

Food Security Modelling

Evgeny A. Kuzmin *

Chair Corporate Economics, Institute of Economics,
Ural State University of Economics, Str. 8-Marta, 62, Ekaterinburg, 620144, Russian Federation

A focus of the paper is a problem of “observability” regarding food security. Known scientific approaches to identification of a similar condition have not provided us with a grounded solution to refer to actual borders of security (or standards of mutual penetration). Their absence makes methodological capacities of modelling essentially disturbed. It is levelling of these contradictions that is an aim of this research. The authors put forward and give a scientific rationale for a hypothesis for fragmentary food security, an essence of which is come down to a research on certain agricultural commodity groups. In a critical review, features of security are specified. A theoretical development of authors’ provisions have resulted in formalization of a number of models built in terms of the dependence factor or inherent openness of the food system. These and other features have made it possible to offer a distinctive technique for an analytical interpretation of findings, including an assessment of risk for lost security condition in a food aspect of the issue.

Keywords: food security, agriculture, security modelling.

1. Introduction

Relevance of a research on food security is difficult to be overestimated. The food issue is undoubtedly one of priority issues in life necessities of the population. Researchers have made different emphases when refer to relevance of the problem, but they all share an idea that there is a principal need to balance a demand and a supply. Determining factors here include the food shortage, trends of a decline in export, a rise of prices for agricultural products and an increase in production costs, a declining paying capacity of customers and a growth of the total population. Available macro-regional imbalances draw attention to an important objective of the best possible redistribution of agricultural resources.

The mentioned and other causes made it possible to accept as a dominant paradigm an idea that food security is a condition, in which domestic needs must be covered to the maximum extent with own resources (Gusakov et al, 2008). However, this is not exactly the case. It would be a mistake to assume that with internalisation of markets, security is only limited to food production. Cross-dependences in a supply of non-food products have begun to play a special part. Pinstrup-Andersen (2009) says that “food security is an important concept, if used with a clear understanding of a meaning of [internal and external – *authors’ note*] of interactions and the essence of interaction with non-food factors”. At the same time, an interpretation of food security is ambiguous and not conventionally established in its scientific understanding. They are informative components of security that represent availability of concepts and models distinctive in their way. It is clear that without revised security criteria and indicators, as well as characteristics of such a condition, a further investigation will be particularly difficult. More for pluralism of opinions see the literature review.

2. Literature review

2.1. Fundamental nature of food security

Food security refers to and belongs to various organizational levels. Many researchers mostly successfully explained all of them in their papers. There is a prevailing idea that the concept of “food security” appeared for the first time in a scientific use in the mid-1970-ies and is associated with the World Conference on Food. It was there where it was clearly formalised that *food security is an uninterrupted availability of sufficient world stocks of vital foods to maintain a steady growth in food consumption and fluctuation maturity concerning production levels and prices* (Report..., 1975).

Aspects in research on food insecurity are multiple and diverse. Among them, we may refer to Coates, Webb & Houser (2003) saying of a measurable evaluation of security. Lawrence, Lyons & Wellington (2013), Panda (2009) refer to an influence of globalization and liberalization in trade relationship. Thomson & Metz (1999), Pollard (2012) refer to regulation of influence consequences. Ilyina (2003) refers to security understood with a secured food supply. Kochanov (1998) says of minimum standards of sensible nutrition, which are only maintained.

* To whom all correspondence should be addressed.

* E-mail: KuzminEA@gmail.com

Anfinogentova (2004) refer to an achieved state of security “in development of the world food market with elimination of trade barriers and formation of such a level of market prices, which represents comparative advantages of countries”, etc.

The starting point to formalize modelling of food security is a research on factors and criteria able to influence a change to a level of security and determine its presence in volatile dynamics of indicators. Depending on an organizational level, a range of indicators included in various models may be unique. However, one may trace some similar approaches to determination of dependent parameters. By convention, they include the following indicators (FAO (2013), Ilyina (2003), Altukhov (2008)): a degree of met physiological needs in nutrition; a level of physical availability of foods; a size of buffer food stocks; a sustainability degree of the subsistence support system; a level of national food self-sufficiency (by a share of imported food resources), etc. All of them summarize an impact of advantages from those factors that describe the current consumption. However, food security is not only a result of actions caused by those conditions, but also by non-food factors. This conclusion has already found its detailed arguments. Therefore, a set of indicators should be expanded. Mainly at the expense of parameters that define a degree of dependence by both imported non-food supply and export-prevalence of these commodities in a consumption structure. At the same time, it is possible that there are more important regularities, which should be seen as supreme.

2.2. Models and concepts

Returning to an issue of food security modelling, we need to refer to some concepts and approaches significant for purposes of the research. Uncertainty against definitions of food security leads to almost the same uncertainty to establish reference positions for models. In due time, Glazyev, Chekavinsky & Selimenkov (2014), Sapkina (2012), Ivanova & Glukhova (2012), Panda (2009), Coates, Webb & Houser (2003), Holden, Bekele, Shiferaw & Pender (2005), Halliru (2013) and many others referred to this subject. Among the models, there are also those that have been proposed by field-specific organizations. They may include the model offered by IMPACT institute, the model offered by AsiaFish (in an analysis in the fish industry), the model by UNICEF, the model by AGLINK-COSIMO, the model by USDA-ERS. A list of models is extensive and has regular updates. This research is not an exception and makes its contribution into a search for a solution to this issue. In further development of the authors' approach, we will explain in more details the content and principles, according to which some of the mentioned models were designed.

A. Model for Policy Analysis of Agricultural Commodities and Trade (IMPACT) (2002) in its statements is very close to the authors' view. Thus, it assumes that subsystems of the global food market are linked with trade and specialization. The demand within the model depends on an influence of incomes and a population growth, while in its turn an increase in production depends on prices for crops and productivity growth rates. In general, the model allows us to “minimize a sum of the net trade” at the global market and at the same time seeks to establish equilibrium prices. It is worth mentioning that productivity of a decline in the net trade with foreign markets is ambiguous.

B. The USDA's Economic Research Service proposed the model USDA-ERS “to design food consumption, an access to it and inherent challenges with foods for 67 countries with low income” (2002). The model evaluates food security based on a gap between the forecasted domestic consumption (including net exports) and the required consumption based on rational standards. Thus, there is an *essential assumption that the security state is only limited to available foods; moreover, a source of foods becomes unimportant*. According to the model, it is clear that the foreign trade turnover is a key determinant that defines abilities of import and export of foods. From its origin, the model assumes that countries are unable to cover domestic needs at the expense of their domestic production, so their focus is import. A significant volume of imported supply of foods means that world prices have been in total introduced to the domestic national market. An exogenous nature of global prices under the model allows us to make forecasts for the consumption of other commodities with a simple analysis of growth trends in a supply of food crops.

C. It is much easier compared to the approach by IMPACT to design the model proposed by Pollard (2012). Its incoming physical parameters include available resources, financial support, skills and knowledge. At the same time, factors that provide security are a cost of foods, their diversity, as well as their accessibility, regularity of supply and their quality. The model is essentially verbal and does not imply any estimations.

Others. A number of researchers have focused on a design of food security integration models. This is inefficient, to our mind. So, Pankova (2013) with purposes of an analysis offers to use “a factor of national food security”, calculated as a multi-dimensional vector of factors with quantitative and qualitative evaluations (mostly expert). This approach does not obviously hold water. Another example of the built integrated model is Grishakina & Zaretskaya (2013). Academic consistency of these models is highly questionable as it is extremely difficult to present “security” as a generalized indicator. We have convincingly proved that in a field of foods, it will be much

fair to talk of *fragmentary security*, that is, *security for a particular commodity group*, rather than present a non-consistent provision as an average value that makes it possible to identify a particular qualitative state in a reliable way.

3. Methods and solutions

3.1. Model of fragmentary food security

A scientific issue of security modelling is explained in giving grounds for ultimate values of mutual penetration into food markets of countries that in terms of trade are independent. Based on this, we are inclined to believe *that food security must be designed in terms of abilities of the domestic market (production) to make physical delivery of agricultural resources and products (or further referred to as the agricultural commodity groups), initially excluding the price factor (!), that is in kind instead of cost estimates*. The main hypothesis of the authors' model is that *fragmentary food security is described with such a level of domestic production in certain agricultural commodity groups (a level of substitution for domestic consumption), at which together with stocks of production, a value of the net export capacity is a value of the acceptable import volume of relevant agricultural commodity groups. At the same time, the national consumption in the context of denied openness of markets may be met at the expense of domestic production and involved production stocks* (Note 1).

As we have mentioned earlier, the principal matter here is a search for criterion levels. At the same time, a review of literature has shown that publications mostly do not include reasonable estimates for barrier values of indicators, which describe security in general terms. To solve this guiding shortcoming, we have put forward a technique to find ultimate levels of mutual penetration into food markets of various countries (territorial entities) in terms of free turnover of agricultural resources and goods.

A basic parameter in the technique is a usage level of production capacity. It shows how large the stocks are to build-up an input of agricultural resources, and at the same time build-up capacities to meet food needs. All this allows us to estimate a size of the net food export potential:

$$NEP_i = \frac{Pd_i}{L_{pd}} \times 100 - [Cd_i + Ui_i + Sc_i] \cdot \quad (1)$$

where NEP_i – net food export potential of the i -th commodity in kind; Pd_i – domestic production of the i -th agricultural commodity in kind; L_{pd} – usage level of annual average (torque) production capacity in %; Cd_i – final consumption of the i -th agricultural commodity in kind, including losses in kind; Ui_i – interim usage for production purposes in kind; Sc_i – changes to stocks of the i -th agricultural commodity in kind.

The value of net food export potential (NEP) may be either positive or negative. In cases where the NEP takes positive values, a local food market have all the opportunities to export agricultural commodities; in case of negative values, on the contrary, a need in import is a forced necessity to meet in full the domestic demand. In this way, we outline an important role of NEP to find ultimate capabilities of the market.

To find the criterion level of substitution of import for domestic production of agricultural resources and foods, we need to correlate an obtained value of NEP and a value of domestic consumption, including changes to stocks and the intermediate and final use, including losses. In a variative change to NEP, the system of equations may look like follows:

$$\begin{cases} NEP_i \leq 0 : BL_i^{imp} = 0, \\ 0 < NEP_i < [Cd_i + Ui_i + Sc_i] : BL_i^{imp} = \frac{NEP_i}{Cd_i + Ui_i + Sc_i}, \\ NEP_i \geq [Cd_i + Ui_i + Sc_i] : BL_i^{imp} = 1. \end{cases} \quad (2)$$

where BL_i^{imp} – barrier level of substitution of imports for domestic production of agricultural resources and foods.

3.1.1. Derivative analytical indicators for the model

Besides basic parameters by formula (1) and (2), it is possible to calculate derivative analysis indicators that represent an absolute and relative potential of fragmentary food security.

The absolute potential is associated with the substitution barrier level (BL). On the one hand, an assessment of the absolute potential aims to find a value of a possible and acceptable change to import. In this case, the only

acceptable option of calculations is the calculation, where there are no restrictions regarding changes to basic indicators. With regard to the relative potential of fragmentary food security, the applied similar idea will be unjustified as the potential is to show a difference between the current condition and the perfect one. Then, the absolute potential is expressed under two conditions:

$$(3) \quad \begin{cases} NEP_i \geq [Cd_i + Ui_i + Sc_i]: AP_i^{es} = NEP_i - Ui_i - Cd_i - Sc_i, \\ NEP_i < [Cd_i + Ui_i + Sc_i]: AP_i^{es} = NEP_i - EP_i. \end{cases}$$

where AP_i^{es} – absolute potential of fragmentary food security, or in other words, an acceptable quantitative change to the imported agricultural commodities (with “>0” - a growth of import, with “<0” - a decline in import); EP_i – import of the i-th agricultural commodity in kind.

As part of an assessment of the relative potential, one needs to pay attention to the fact that his/her calculations do not take into account a scope of the dynamics for values of the barrier level of substitution defined within the boundaries [0, 1]. It seems that relative potential value show a barrier share of import, with which the situation with security in general is maintained (or, at least, not disturbed).

$$(4) \quad RP_i^{es} = BL_i^{imp} - CP_i^{imp},$$

where RP_i^{es} – relative potential of fragmentary food security of the i-th agricultural commodity.

A development of the approach regarding derivative analytic indicators for the model allows us to proceed with an evaluation of the riskiness of (risk) for the system’s going beyond the security state in terms of food security, which is an integral part of the holistic methodology.

3.1.2. Riskiness assessment of going beyond a state of security

Riskiness as a universal characteristic reflects a probability that specified events will occur. Parameters resulted from the model as a pure export potential, the barrier and the current level of substitution of import for domestic production are in full unable to answer a question of a magnitude of the risk inherent to this or that actual value of these parameters. They only give a general idea of trends in development of food markets, from which one may make a reasoned judgment on some areas of threats. However, it is impossible to have a clear idea of a prospective scale of their influence.

To solve a task of the riskiness assessment, one should adhere to a number of provisions. First, a crucial role in an indicative definition of security belongs to a barrier level of substitution of imports for domestic production of agricultural resources and foods. Second, the riskiness depends on proximity of the current (actual) and barrier levels of substitution of import for domestic production. At the same time, the barrier level varies dynamically over time. Thus, the riskiness is not constant and torque. Consolidation of these provisions allows us to proceed with a technique of calculation. In our view, the riskiness assessment should be based on the Laplace distribution function. Mathematical formalization involves consideration of such values, as the lower limit and the upper limit of an acceptable range of benchmark fluctuations (i.e. a search for borders for the security standard), a figure of its average value for a period and its standard deviation.

$$(5) \quad R(a < CP_i^{imp} < BL_i^{imp}) = 1 - \left[L\left(\frac{BL_i^{imp} - \bar{f}(CP_i^{imp})}{\delta(CP_i^{imp})}\right) - L\left(\frac{a - \bar{f}(CP_i^{imp})}{\delta(CP_i^{imp})}\right) \right].$$

$$L(z) = \frac{1}{\sqrt{2\pi}} \int_0^z e^{-\frac{t^2}{2}} dt.$$

where $R(a < f_1 < BL_i^{imp})$ – risk value with regard to non-achieved target levels of fragmentary food security by the i-th agricultural good; $L(z)$ – Laplace’s function; a – initial barrier level for substitution of imports for domestic production equal or closer to zero ($a = 0$ or $a \rightarrow -0$); $\bar{f}(CP_i^{imp})$ – average value for index for a period under review; $\delta(CP_i^{imp})$ – mean square deviation for index for a period under review.

It should be emphasized again that the barrier level of substitution for each period changes, therefore, a calculation of the risk should be only made with a successive replacement of the barrier level and a record of an obtained value for this stage of calculations. A quality and accuracy of risk estimates also depend on comprehensive perspective of a research. In cases where a reporting period is short, statistics of the current level of substitution will be incomplete, while the accuracy of estimates will be risky low.

3.2. Model of interdependent fragmentary food security

In terms of a free turnover of agricultural resources (including all agricultural commodity groups), fragmentary food security acts as a balancer between “rationalities” to establish an equilibrium in the common market. Assuming that the food market is not homogeneous and subject to control by various actors, we can conclude that a logic of one actor to achieve the equilibrium will also differ from a logic of the others; sometimes dramatically. Herein, there is a crucial conclusion that rationality is not strictly defined and varies depending on an extent of coverage. In other words, the agro-industrial system of any territorial unit (region) has its own behaviour rationality, and this behaviour may differ from the rationality of a system at a higher organizational level.

Such assumption results in a tutorial incompleteness of the fragmentary food security model, which needs supplements. We believe that the model will be more complete in terms of an effect of mutual penetration using the elimination technique. Then separated evaluations of security against individual food markets will act as an element of comparison with evaluations in general. At the same time, an impact or a contribution of a subsystem in consideration is excluded. As a result, for actors, there will be an essential a gap between values of current and barrier levels of substitution of imports for domestic production both “within the system”, i.e. in an idea of separate security, and “beyond the system”, with a combined account of all actors’ security, excluding an actor under consideration. Having specified principal distinctions of the authors’ approach, we may proceed with its formalization.

Firstly, it is worth referring to a chart, following which we put forward a hypothesis for applicability of the elimination technique in a comparative analysis of food security for various actors within a single system – in the common market (see Figure 1).

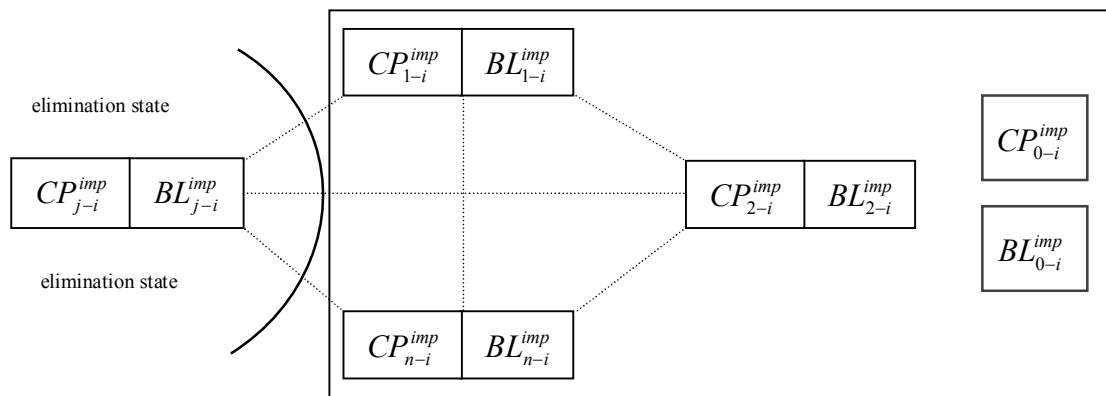

Figure 1. Chart of relative interaction between actors in evaluations of current and barrier substitution levels

Note: CP_{j-i}^{imp} – current level of substitution of imports for domestic production for j-actor by i-th agricultural commodity; BL_{j-i}^{imp} – barrier level of substitution of imports for domestic production for j-actor by i-th agricultural commodity; CP_{n-i}^{imp} – current level of substitution of imports for domestic production for n-actor in the external environment by i-th agricultural commodity; BL_{n-i}^{imp} – barrier level of substitution of imports for domestic production for n-actor in the external environment by i-th agricultural commodity; CP_{0-i}^{imp} – current level of substitution of imports for domestic production of n actors in the external environment in general by i-th agricultural commodity; BL_{0-i}^{imp} – barrier level of substitution of imports for domestic production for n actors in the external environment in general by i-th agricultural commodity.

Figure 1 includes a conceptual chart of interaction between various actors (subsystems) by one agricultural commodity group. Taking into account that each actor has its own characteristics for the current and barrier levels of substitutions, there is a guidance challenge to identify a contribution of a single actor in aggregate food security. To solve the task, we assume them that security of a group depends on security of each actor. That is why we use the elimination technique (similar to the factor analysis), which makes it possible to determine a degree of actors' participation to overcome supply-demand imbalances for agricultural resources and foods. The key question here is the question of dominance of one actor against the others.

Secondly, one should estimate a usage level of the annual average production capacity, which is calculated as a weighted average value relative to domestic production. For this, a number of transformations is necessary based on the previously presented guidance apparatus.

(6)

$$L_{pd_{0-i}} = \frac{\sum_{j=1}^n [Pd_{ji} \times L_{pd_{ji}}] - Pd_{ji} \times L_{pd_{ji}}}{\sum_{j=1}^n [Pd_{ji}] - Pd_{ji}},$$

where $L_{pd_{0-i}}$ – usage level of annual average production capacity for “the others in general”; Pd_{ji} – domestic production of the i-th agricultural commodity in kind by j-actor; $L_{pd_{ji}}$ – usage level of annual average production capacity of the i-th agricultural commodity by j-actor.

Third, we define the current level of substitution of imports for domestic production for the system in time of elimination, i.e. “for the others in general”. Findings will thus represent different capacities of actors in meeting food needs on their own. To our mind, it is possible to make a hypothetical assumption that the system as a group of actors (territorial entities) is open and not closed. Thus, the current level of substitution for “the others in general” may be presented as follows:

(7)

$$CP_{0-i}^{imp} = \frac{\sum_{j=1}^n [CP_{ji}^{imp} \times (Cd_{ji} + Ui_{ji} + Sc_{ji})] - CP_{ji}^{imp} \times (Cd_{ji} + Ui_{ji} + Sc_{ji})}{\sum_{j=1}^n [Cd_{ji} + Ui_{ji} + Sc_{ji}] - (Cd_{ji} + Ui_{ji} + Sc_{ji})},$$

where CP_{0-i}^{imp} – current level of substitution of imports for domestic production of agricultural resources and foods for the system in time of elimination against j-actor; Cd_{ji} – final consumption of the the i-th of the agricultural commodity group in kind, including losses against j-actor; Ui_{ji} – for production purposes, the intermediate use of the i-th of the agricultural commodity group in kind by j-actor; Sc_{ji} – changes to stocks of the i-th of the agricultural commodity group in kind by j-actor.

Finally, fourth, a final stage in modelling of interdependent fragmentary food security is a calculation of the barrier level of substitution for a set of actors, excluding an actor, against which a comparison is made. In the calculation of the barrier level in time of elimination, a value of annual average production capacity is used by formula (6), as well as other parameters similar to the barrier level by (1) and (2) to evaluate fragmentary security.

(8)

$$BL_{0-i}^{imp} = \frac{\frac{\sum_{j=1}^n [Pd_{ji}] - Pd_{ji}}{L_{pd_{0-i}}} \times 100 - \left[\sum_{j=1}^n [Cd_{ji} + Ui_{ji} + Sc_{ji}] - (Cd_{ji} + Ui_{ji} + Sc_{ji}) \right]}{\sum_{j=1}^n [Cd_{ji} + Ui_{ji} + Sc_{ji}] - (Cd_{ji} + Ui_{ji} + Sc_{ji})},$$

where BL_{0-i}^{imp} – barrier level of substitution of imports for domestic production of agricultural resources and foods for the system in case of elimination regarding j-actor.

Based on findings from levels of substitution of imports for domestic production in both a separate and interdependent (in case of elimination) form, it becomes possible to make a comparative analysis and find a degree of actors' mutual penetration into food markets.

4. Discussion

Within the authors' view of food security modelling, the mutual penetration (or combination) of subsystems is not worth to be explored in a pairwise comparison. Instead, in a ratio of proportions of the main indicator, which as such says of available or non-available state of security. In this case, the matter is the level of substitution (CP and BP). In a further development of the methodology for the approach, the ratio of proportions will be found with defined "reduced" values of the current and barrier levels of substitution; in this regard, special factors (coefficients) will be introduced. These coefficients refer to adjustments to levels, as for the actor (subsystem) and the system as such they will be placed at some distance from each other because of differences in calculation methods. The logic of "reduction" is explained with a chart in Figure 2.

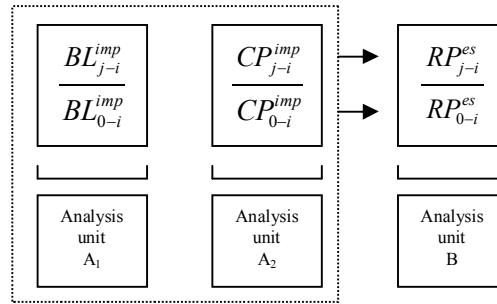

Figure 2. Units in analysis of food security state

Note: RP_{j-i}^{es} – reference potential of fragmentary food security for the i -th commodity group in the agriculture against j -actor; RP_{0-i}^{es} – reference potential of fragmentary food security for the i -th commodity group in the agriculture for n actors (subsystems) of the external environment.

From Figure 2, it is clear that an analysis consists of a few units. The first one (A unit) deals with elimination of food insecurity, while the second one (B unit) points out to a need in an alignment of proportions between the values obtained, but with evaluations of their relative potential. From there we assume that a change to the barrier and the current levels of substitution depends on linear distribution; a proportional increase (or decrease) in one of them will result in a proportional increase (or decrease) in the other. Otherwise, an analytical comparison is meaningless. As a result, a written calculation of reduction factors will look like:

$$k_{\alpha}^0 = \frac{CP_{j-i}^{imp}}{CP_{0-i}^{imp}} \text{ and } k_{\alpha}^j = \frac{1}{k_{\alpha}^0} = \frac{CP_{0-i}^{imp}}{CP_{j-i}^{imp}}, \quad (9)$$

$$k_{\beta}^0 = \frac{BL_{j-i}^{imp}}{BL_{0-i}^{imp}} \text{ and } k_{\beta}^j = \frac{1}{k_{\beta}^0} = \frac{BL_{0-i}^{imp}}{BL_{j-i}^{imp}}.$$

where k_{α}^0 – reduction factor for the current level of substitution in baseline comparison with "the others in general"; k_{α}^j – reduction factor for the current level of substitution in baseline comparison with j -actor; k_{β}^0 – reduction factor for the barrier level of substitution in baseline comparison with "the others in general"; k_{β}^j – reduction factor for the barrier level of substitution in baseline comparison with j -actor.

Depending on what is taken as a conditional standard of food security state, there may be used either coefficients of reduction in baseline comparison with "the others in general", or j -actor (subsystem). In the both cases, there will not appear any controversies in an interpretation of findings.

The authors' approach implies that mutual penetration or involvement with ratio of proportions is estimated from a comparison of current values of the level of substitution of imports for domestic production (using CP_{0-i}^{imp} and

CP_{j-i}^{imp}). The resulting value gap_{cp} points to a difference between current levels of substitution, supposing the barrier level values were identical. From this perspective, it becomes possible to identify those actors (subsystems), for which involvement in the common food market is the highest or the lowest, showing at the same time a kind of a subordination degree. The gap-comparison of values is made with “reduction”:

$$\overline{CP_{0-i}^{imp}} = CP_{0-i}^{imp} \times k_{\beta}^0, \quad (10)$$

$$gap_{cp} = \overline{CP_{j-i}^{imp}} - \overline{CP_{0-i}^{imp}} \quad \text{or} \quad gap_{cp} = CP_{j-i}^{imp} - CP_{0-i}^{imp} \times k_{\beta}^0,$$

where $\overline{CP_{0-i}^{imp}}$ – comparative value of the current level regarding the substitution of imports for domestic production in baseline comparison with j-actor.

Similarly, using formula (10), we may make reduction regarding the barrier value of the substitution level when j-actor is taken as a comparative base:

$$\overline{BL_{0-i}^{imp}} = BL_{0-i}^{imp} \times k_{\alpha}^0, \quad (11)$$

$$gap_{bl} = \overline{BL_{j-i}^{imp}} - \overline{BL_{0-i}^{imp}} \quad \text{or} \quad gap_{bl} = BL_{j-i}^{imp} - BL_{0-i}^{imp} \times k_{\alpha}^0,$$

where $\overline{BL_{0-i}^{imp}}$ – comparative value for the barrier level of substitution of import for domestic production in baseline comparison with j-actor.

A comparison of barrier values using reduction factors plays an important role to identify the characteristics and specifics of food systems, when a difference between development potentials influences differences in acceptable fluctuations for a substitution of imported products for domestic production. The barrier level integrates those conditions and factors that put the framework for food security. From there, we may quite reasonably conclude that the barrier level of substitution is an indicator of the subsystem’s (independent food market) ability to withstand challenges and threats of mutual penetration and subordination.

5. Conclusion

A shift from an autarky paradigm to a paradigm of open markets has emphasized importance of research on ways to maintain food security to preserve incentives and favourable conditions for development. Our research has demonstrated that food security modelling is in line with a search for boundary (barrier) values for a number of basic parameters, including firstly a level of substitution when imported resources are a substitution for domestic agricultural production. An important aspect of security is its fragmentary nature. In other words, food security may be only referred to specific commodity groups in the agriculture. This has ultimately led to a need in decomposition for an analysis of security state when, on the one hand, we explore the isolated subsystem, while, on the other, hand we explore its participation and involvement in the common food market.

In summary, the mentioned authors’ approach to modelling makes it possible to take another view of the issue of identification for the security state and give a rationale for a criterion of “normal” mutual penetration into food markets. Theoretical and methodological supplements that cover a range of issues regarding the riskiness assessment and other aspects of the mentioned issue have allowed to have a comprehensive approach to solve the problem of observability for the security state and identify specifics of its dynamic measurement. We believe that in the future, these methods will help to build a balanced strategy to respond to threats in development of the agro-industrial complex.

Acknowledgement

The Russian Scientific Foundation (RSF) supported this research, project No. 14-18-00574 “The Information and Analytical System Anti-Crisis: Region Diagnosis, Threat Assessment and Scenario Forecasting to Preserve and Strengthen Economic Security and Raise Welfare in Russia”.

Notes

Note 1. The provision on fragmentary security includes an assumption that an available production stock may be immediately engaged when there is a need in meeting an available shortage of food and agricultural resources (agricultural commodity groups).

References

1. Altukhov, A.I. (2008). Country's food security and its evaluation. *Economics of Agricultural and Processing Enterprises*, 5: 1-5.
2. Anfinogentova, A.A. (2004). *Food security in Russia: Problems and Prospects*. Moscow: Institute of Agrarian Problems of RAS; Saratov University Press: 7
3. Chekavinsky, A.N. & Selimenkov, R.Yu. (2014). Modelling regional food security. *Economic and Social Changes: Facts, Trends, Forecast*, 4 (34): 226-235.
4. Coates, J., Webb, P., & Houser, R. (2003). *Measuring Food Insecurity: Going Beyond Indicators of Income and Anthropometry*. Washington: FANTA.
5. *Food Insecurity in the World 2013. The multiple dimensions of food security*. (2013). Rome: Food and Agriculture Organization of the United Nations (FAO).
6. Grishakina, N.I., Zaretskaya, A.S. (2013). Integral assessment of food security level for the Novgorod Oblast. *Bulletin of the Yaroslav the Wise Novgorod State University*, Vol. 1, 74: 20-26.
7. Gusakov, V.G. et al. (2008). *Food security: terms and concepts: encycl. ref.* Minsk, Belarusian Science, p. 6.
8. Halliru, S.L. (2013). Climate Change and Food Security in Kano Nigeria: A Model for Sustainable Food Production. In Behnassi, M., Pollmann, O., Kissinger, G. Sustainable Food Security in the Era of Local and Global Environmental Change. Springer Science & Business Media.
9. Holden, S.T., Bekele, S., Shiferaw, B.A., & Pender, J. (2005). Policy Analysis for Sustainable Land Management and Food Security in Ethiopia: A Bio economic Model with Market Imperfections. *Intl Food Policy Res Inst.*
10. Ilyina, Z.M. (2003). Food security: criteria and evaluation parameters. *Proceedings of the National Academy of Sciences of Belarus. Agrarian Sciences Series*, 1: 3-9; 6
11. Ivanova, I.A. & Glukhova, T.V. (2012). *Analysis and modelling of production-consumption ratio for agricultural products. Modern Issues of Science and Education*, 6: 462.
12. Kochanov, M.A. (1998). Key directions to ensure food security in Russia. *Scientific bases to develop and implement regional programs of stabilization and development in the agribusiness*. Novosibirsk: SibNIIESKH: 251-252.
13. Lawrence, G., Lyons, K., Wellington, T. (Eds.). (2013). Introduction: Food Security, Nutrition and Sustainability in a Globalized World. In *Food Security, Nutrition and Sustainability*. Earthscan.
14. *On food security in Russia*. Report made by expert group from the Izborsk club headed by RAS member S.Yu. Glazyev. Available at: <http://www.dynacon.ru/content/articles/1725>.
15. Panda, M. (2009). Trade liberalization, poverty, and food security in India. *Intl Food Policy Res Inst.*
16. Pankova, V. N. (2013). Ratio of national food security as a basis to model international food flows. *Economic Bulletin of the SFD*, 8 (71): 45-54.
17. Pinstrup-Andersen, P. (2009). Food security: Definition and measurement. *Food Security*, 1: 5-7. <http://dx.doi.org/10.1007/s12571-008-0002-y>
18. Pollard, C. Selecting Interventions for Food Security in Remote Indigenous Communities. In Farmar-Bowers, Q., Higgins, V., Millar, J. (Eds.). (2012). *Food Security in Australia: Challenges and Prospects for the Future*. Springer Science & Business Media: 97-112. http://dx.doi.org/10.1007/978-1-4614-4484-8_7
19. *Report of the World Conference on Food, held in Rome on 5-16 November 1974*. (1975). UN, New York.
20. Rosegrant, M.W., Meijer, S., Cline, S.A. (2002). *International Model for Policy Analysis of Agricultural Commodities and Trade (IMPACT): Model description*. Washington, DC: International Food Policy Research Institute. Available at: www.ifpri.org/lthemes/impact/impactmodel.pdf.
21. Sapkina, E.A. (2012). Mathematical model of macro dynamics at regional agricultural market in terms of food security factor. *Mining Information and Analytical Bulletin (Journal of Science and Technology)*, 9: 325-328.
22. Thomson, A.M., Metz, M. (1999). *Implications of Economic Policy for Food Security: A Training Manual*. Food & Agriculture Org.
23. Umati-Deininger, D., Shapouri, S. Food Security: Is India at Risk? (p. 49). In Lal, R., Hansen, D.O., Uphoff, N. (Eds.). (2002). *Food Security and Environmental Quality in the Developing World*. CRC Press.