



Munich Personal RePEc Archive

# **Evolution towards higher net profit in a population of ensembles of ensembles leads to division of labour**

Friedrich, Thomas

Humboldt-Universität zu Berlin

27 March 2018

Online at <https://mpra.ub.uni-muenchen.de/85517/>

MPRA Paper No. 85517, posted 30 Mar 2018 10:59 UTC

# **Evolution towards higher net profit in a population of ensembles of ensembles leads to division of labour**

T. Friedrich

## **Abstract**

In this model the basic ensemble consists of a source and a sink, three basic ensembles constitute an organism or company (both an ensemble of ensembles) and nine organisms/companies form a population or a branch of industry. Each organism is composed of either connected or unconnected ensembles. Linear cost-functions and saturating benefit-functions create superadditivity (better net profit) through a rational and peaceful transfer of substrate within a basic ensemble. Transfers by force and deception are not yet considered. All ensembles have an identical and limited concentration range and all concentrations are of the same probability. Random mutations change cost factors ( $cf$ ), Michaelis-Menten constants ( $K_m$ ) and the maximal reaction velocities ( $V_{max}$ ) in source and sink of the basic ensemble.  $K_m$  and  $V_{max}$  shape a saturating benefit-function in Michaelis-Menten type enzyme kinetics resembling the utility function in economics. The result of mutations in the basic ensemble is a higher or lower cumulative superadditivity of an organism/company and its master if installed. The most effective organisms or masters prevail within the population. Recombination of ensembles between organisms accelerates evolution. Independent of the starting point and with or without a fix cost  $I$  observe the evolution towards strong asymmetry and inequality with a division of labour resulting in the development of a collector and a manufacturer. Although I observe a win-win situation reciprocity will become a necessity.

ensemble, transfer space, benefit, cost, utility, net profit, mutation, recombination, division of labour, asymmetry, inequality, quantity to quality transition, complexity

## Resume of the old and static model

Source and sink are important concepts in Physics (Thermodynamics, Electronics) and especially Biology (1, 2); in Economics (business management) this concept is used, too (3). In the past I investigated simple ensembles consisting of only one source and one sink. Source and sink use the same substrate which has a benefit aspect and a cost aspect simultaneously. The different parameters of the benefit-function and the cost-function are fixed and stay unchanged over time (4).

The cost-function ( $c$ ) is linear and calculated from the simple biochemical parameter substrate concentration  $[S]$  with the dimension millimolar (mM) and a cost factor  $c_f$  with the dimension cost per millimolar (c/mM). The result is a linear function with the dimension cost ( $c$ ). A fix cost ( $f_c$ ) was and is only included when specifically mentioned.

$$c = [S] \text{ (mM)} * c_f \text{ (c/mM)}$$

The benefit is related to a product made from the substrate. The biochemical equivalent to the productivity of benefit ( $b$ ) is the reaction rate  $V$  (velocity in micromoles per minute). The rate is calculated from the Michaelis-Menten equation. The benefit factor  $b_f$  has the dimension benefit times minutes per micromole. The result is a saturating function with the dimension  $b$ . This function resembles the utility function in economics.  $K_m$  is an enzyme-typical constant (dimension millimolar, mM).  $V_{max}$  is the maximal reaction velocity in micromoles per minute.

$$b = V \text{ (}\mu\text{m/min)} * b_f \text{ (b*min/}\mu\text{m)}; V = [S]/(K_m+[S]) * V_{max} \text{ (}\mu\text{m/min)}$$

Every substrate has simultaneously both features: benefit and cost. When the substrate concentration (amount per volume) will increase, source and sink will change from benefit domination to cost domination (figure 1). Benefit and cost are place-holders and could be measured

themselves in other units like Euro (€) or kilojoule (kJ). When benefit and cost are of identical quality we can subtract them and learn whether cost or benefit will dominate: € or kJ earned ( $b$ ) - € or kJ spent ( $c$ ).

Figure 1

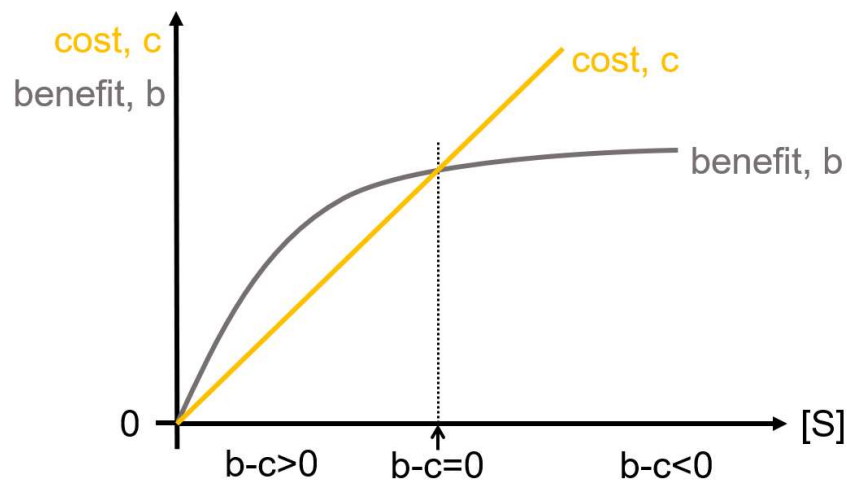

Figure 1

A source or a sink will appear in three different conditions depending on the concentration of substrate. At low substrate concentration we observe benefit domination ( $b-c>0$ ), at high substrate concentration we will observe cost domination ( $b-c<0$ ) and both areas are separated by a point where benefit and cost are of identical size ( $b-c=0$ ).

When two parties come together with unequal distribution of substrate there will be the possibility of a peaceful and rational transfer from the side with cost domination (high substrate concentration - a source,  $b<c$ ) to the side with benefit domination (low substrate concentration - a sink,  $b>c$ ) (figure 2, green arrow). The source will get rid of a large cost although there is a small loss in benefit and the sink will gain a big benefit although there is a small gain in cost. The result for the ensemble of both can be quantified as a net profit. The net profit for the ensemble will be positive and superadditive if the benefit of source minus cost of source plus benefit of sink minus cost of sink is larger after the transfer

than before. If we observe the net profit before and after a transfer for a whole concentration range in source and sink the results are different surfaces within the transfer space (figure 2 right, 4). His coordinates are substrate concentration in source and sink and net profit of the ensemble of both. The volume between the two surfaces is positive or negative and is integrated from  $1000 \times 1000$  columns with the volume  $np \cdot mM^2$ .

Figure 2

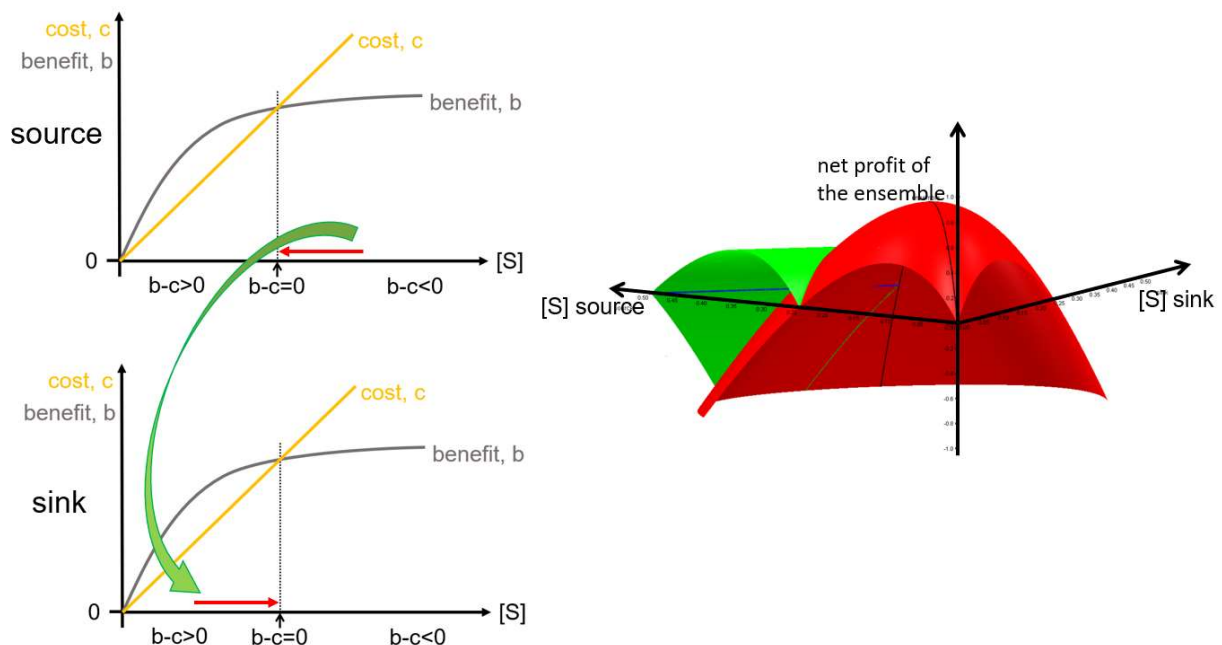

Figure 2

The peaceful and rational transfer (green arrow, left) of substrate from source with cost domination ( $b-c < 0$ ) to sink with benefit domination ( $b-c > 0$ ) will result in superadditivity (green surface on the right) in comparison to no transfer (red surface on the right; simple additivity of net profit in source and sink). This can be visualized in the three-dimensional transfer space (right). The volume between the green and the red surface is the total superadditive net profit after all transfers within a certain concentration range. Symmetric ensembles (this figure) have identical benefit and cost-functions in source and sink, asymmetric ensembles differ at least in one of the function parameters (cost factor, benefit factor,  $K_m$  value,  $V_{max}$  value). The little red arrows indicate an identically sized decrease of substrate concentration in source and increase in sink after a transfer of substrate within the closed system. The simultaneous arrival at  $b=c$  is only possible in one single point (strict symbiosis). Usually one side will not reach  $b=c$  because the other has already arrived at  $b=c$ ; the starting point of force and deception. The total amount of substrate within the ensemble stays unchanged. Substrate is just rearranged between two compartments.

In the case of a peaceful transfer there will be only larger net profits (superadditivity) in comparison to no transfer. The ensemble is only active when rational (figure 2, green surface always on top); two Homo Economicus in action.

Complexity develops by asymmetric features of the ensemble (5) or through the existence of entanglement between source and sink. There, a partial or complete informational identity (genetic relationship) makes it necessary to consider besides a quantitative balance of the net profit also a qualitative balance of the net profit (6). Further complexity arises from the use of force and deception within the ensemble (7, 8).

Besides independent ensembles there are dependent ensembles controlled by a master. In well informed and strong ensembles (two Homo Economicus, an ideal) a transfer will never be due to force and deception. Therefore, the transfer is based on rationality (get rid of substrate in cost domination, gain substrate in benefit domination) and results in a win-win situation characterized by superadditivity only. Not only both sides are unable to force or deceive each other also the master is unable to subjugate source and/or sink. In such a case of equally strong and rational parties he can only act as honest broker. All ensembles of this paper will be peaceful ensembles. In case of a master a brokerage fee is not included with exception of one example. In asymmetric ensembles or in symmetric ensembles with force or deception used by source or sink or the master there will be additional superadditivity but also subadditivity (7, 8). The evolution of ensembles learning to use force and deception is investigated in a separate paper.

When we look top down onto the transfer space we look at a surface ( $\text{mM}^2$ ) with the coordinates of the substrate concentration in source (0-5mM) and in sink (0-5mM). In the example of figure 3 we look at an

asymmetric ensemble. The concentration plain is cut into 4 unequal areas (area I to IV) by two red lines. The red lines are formed by concentrations where benefit of source minus cost of source or benefit of sink minus cost of sink are zero. Benefit minus cost in source and sink are zero simultaneously in one point. This point will be located for all symmetric ensembles on the light blue line; the line of mixing of substrate which could be also called the line of strict equivalence for them. However, not all ensembles with the point  $b_{so}-c_{so}=b_{si}-c_{si}=0$  on the blue line will be symmetric.

Figure 3

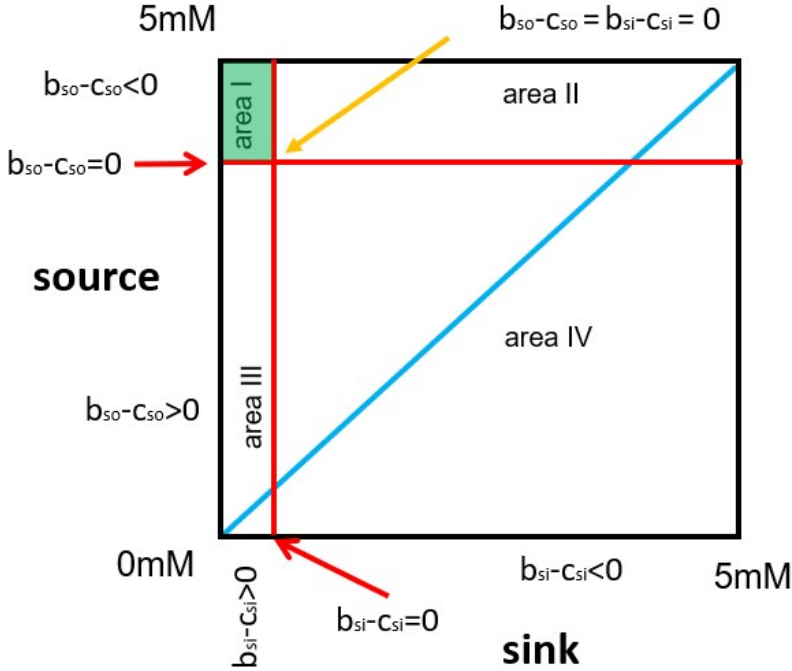

Figure 3

A top down look on the transfer space. The dimension net profit points towards the observer. As example we look at an asymmetric ensemble where cost factor, benefit factor, Km value and Vmax value differ in source and sink. The red arrows point at red lines where in source **or** in sink benefit and cost are equal. The orange arrow points at the only point where in source **and** in sink benefit and cost are equal. The light blue line is the line of strict equivalence for symmetric ensembles. The green area is the area I with a peaceful and rational transfer. In the absence of force and deception the ensemble is only active in area I although all concentrations (0-5mM) have the same probability.

Certain asymmetric ensembles (5) also fall on this blue line but then we will also observe a partial subadditivity in area I. This will happen when  $K_m$ ,  $V_{max}$ , and  $c_f$  in source and sink are in a typical size relation:

A highly productive source is over-saturated ( $b < c$ , very low  $K_m$ , low  $V_{max}$ ) with a very cheap substrate (very small  $c_f$ ) and therefore the low-cost substrate is transferred at free will and completely rational for both sides (area I) to a still unsaturated sink. In case this substrate is for the low productive and very unsaturated sink ( $b > c$ , very high  $K_m$  and high  $V_{max}$ ) of a very high cost (very high  $c_f$ ) we are going to observe “rational” subadditivity. At certain transfer sizes the gain in source by getting rid of cost domination and the gain in sink by benefit domination is a loss for the ensemble of both. Both have an advantage of the transfer but the combined net profits are smaller after the transfer than before. An example for a negative outcome of two rational decisions. We should not forget that we look at a two-dimensional (figure 3) projection of a three-dimensional space (figure 2) with many independent features: two independent substrate concentrations, two independent  $K_m$  and  $V_{max}$  values and two independent cost factors and two independent benefit factors. Peaceful ensembles and peaceful masters are active only in area I; they are not necessarily always superadditive (5) when they act rational.

As there will be several different ensembles with the same two-dimensional appearance we can only discriminate them by their amount of net profit, the dimension pointing in the direction of the observer. This discrimination would be possible with the introduction of a net profit vector in a net profit space. Many problems appear only when higher dimensional phenomena are observed in a lower dimensional space.



## Design of an evolving model

In my past papers and calculations all parameters ( $c_f$ ,  $b_f$ ,  $K_m$ ,  $V_{max}$ ) were fixed and the ensembles were static over time and very simple. The following modifications are added:

- a. I am looking at an organism/company as an ensemble of ensembles. I observe the success of the organism within a population competing for better net profit over the course of many generations. The selection will favour organisms or masters of such organisms with the highest superadditivity from area I. Neither the single ensemble nor source or sink will compete with their counterparts in other organisms; they are completely shielded.
- b. I am going to mutate  $c_f$ ,  $K_m$  and  $V_{max}$  in source and sink. The benefit factor stays in most cases fixed with a value of 1 ( $b \cdot \min/\mu m$ ). A mutational step will be either up or down for the values of  $c_f$ ,  $K_m$  and  $V_{max}$ . The mutational step size is picked from a normal distribution with an expected value 0 and a standard deviation of 0.001 for  $c_f$  and 0.01 for  $K_m$  and  $V_{max}$ . Some values like  $K_m$  in sink will decrease during evolution towards higher net profit but negative values are excluded; the lowest value is set to 0.0001. Out of the nine organism of the population the three best (highest net profit) will be allowed to have one offspring each. The next three organisms in rank will survive and the three lowest in rank will die. One third of the population will be mutated per generation and pairs of two individuals will recombine a transfer space within the same position.
- c. Peaceful independent ensembles and dependent ensembles with a peaceful master are indistinguishable when the master is not collecting a brokerage fee. However, a concentration independent brokerage fee could be interpreted as a fix cost to the ensemble.

- d. The benefit factor is used in some cases as an indicator and measure of the complexity level. Then  $bf$  is set to a fixed value larger than 1 but not by a mutation.

The basic level is the known ensemble represented by a single transfer space (figure 4A). Three ensembles form an organism (a company), an ensemble of ensembles. There are two basic types of organisms. The two different types are an unconnected type (figure 4B) and a connected type (figure 4C).

Figure 4

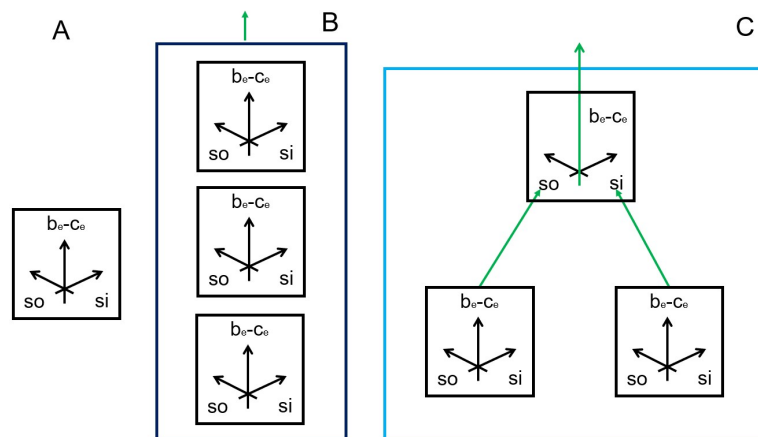

Figure 4

A. The basic ensemble consists of source (so) and sink (si). Input is substrate concentration in source (0-5mM) and substrate concentration in sink (0-5mM). The output is a concentration dependent superadditive net profit ( $b_e - C_e$ ) of the ensemble.

B. An organism (ensemble of ensembles) composed of three ensembles. The ensembles are not connected. The superadditivity of the organism is obtained by adding up the single superadditivity of the three ensembles. The size of the sum (green arrow) will decide whether the organism will survive (the master will succeed) and have offspring or will only survive or is going to die.

C. A different type of organism (ensemble of ensembles) composed of three connected ensembles. The two basic ensembles feed as source and sink with their superadditivity a third ensemble. The size of the superadditivity of the last ensemble (green arrow) will decide whether this organism will survive (the master will succeed) and have offspring or will only survive or is going to die.

Within the unconnected type three ensembles produce net profit from their own pool of substrate and collectively contribute to the total net profit of the organism, a sum of single net profits. Within the connected type the ensembles are arranged in a pyramidal shape. The two ensembles at the bottom produce net profit from their substrate pool. In each ensemble the net profit is calculated in small concentration intervals (100\*0.05mM steps, 10 000 concentration pairs) and handed over to the ensemble on the top as a separate amount of net profit (10 000 portions). One of the lower ensembles will always give its superadditive net profit to the source side of the top ensemble and the other will give the superadditive net profit always to the sink side of the top ensemble. The top ensemble will produce also superadditive net profit from the portions of the lower ensembles. These portions have a frequency distribution. Their value at the higher level is assessed by the benefit factor there,  $bf > 1$ . The final superadditive net profit of the top ensemble is the measure for the success of the organism or the master. The top ensemble is not the master as per definition (7) a third-party master is not directly involved in the production of net profit; he is either a peaceful and honest broker bringing source and sink together or he is using force and deception to induce a transfer of substrate within the ensemble. A master using force and deception will be the protagonist of the next paper. There are two additional types of masters which are also not considered here, the source as master of the sink or the sink as a master of the source (7). They are a part of the ensemble and therefore they experience the effect of their action on the net profit of the ensemble. A third-party master will be able to uncouple his success for some time from the success of an ensemble (8 and paper in preparation). The population is formed by 9 organisms. The population will either consist

only of organisms with unconnected ensembles or with connected ensembles (figure 5).

Figure 5

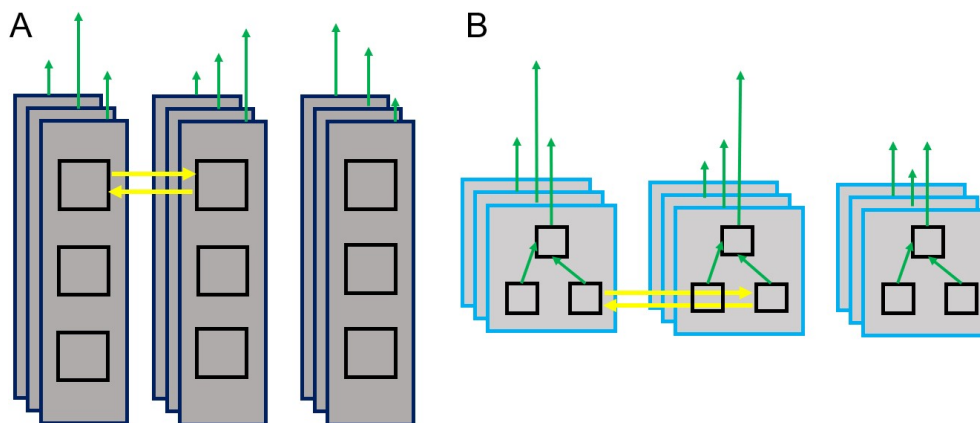

Figure 5

Two different populations. The green arrows indicate the different sizes of superadditive net profit coming out of each organism.

A: The population consists completely of organisms with unconnected ensembles. The basic ensemble is mutated (cf,  $K_m$ ,  $V_{max}$  in source and sink). Recombination is possible between basic ensembles of the same level (yellow arrows). All independent, basic ensembles contribute to the total result of the organism.

B: The population consists completely of organisms with connected ensembles. The basic ensemble is mutated (cf,  $K_m$ ,  $V_{max}$  in source and sink). Recombination is possible only between basic ensembles of the same level and the same function as e.g. a provider from sink of the top ensemble (yellow arrows). The benefit factor in the top ensemble is a measure of the leverage due to complexity. The final result of the organism is the net profit of the top ensemble.

Recombination events are only possible within the same level and function of the basic ensembles. Recombination could also be made on the level of the single kinetic values (bf, cf,  $K_m$ ,  $V_{max}$ ) but is not used here. The aim is to avoid conflicting effects resulting from mixing features of a source with features of a sink. In nature such negative effects are avoided by mating barriers, species formation and other forms of segregation.

## Results and Discussion

### Organisms with unconnected basic ensembles:

The criterion for survival of a single organism or the master of a single organism in a population of similar entities is the sum of the superadditivity produced in the three basic ensembles. The concentration range for all 27 basic ensembles in the population is 0-5mM. The mutations take place on the level of  $c_f$ ,  $V_{max}$  and  $K_m$  in source and sink in a total of 162 places. The direction of the change is random. However, a decrease in superadditivity will eliminate the mutation from the population. Recombination is performed on the level of the basic ensemble.

All 9 organisms start at the same initial starting point. Due to mutations the parameters  $c_f$ ,  $K_m$  and  $V_{max}$  in source and sink of all basic ensembles in every organism within the population are changing. Although all concentrations have the same probability the ensemble is only active in area I. There, the source is characterized by cost domination and the sink by benefit domination.

On the first glance it would be expected that cost for every single party (source or sink) should be low ( $c_f$  small) and the benefit should be high (low  $K_m$ , high  $V_{max}$ ) to have a large benefit after the cost is subtracted – a large net profit. In an ensemble this is different. The ensemble has a strong internal asymmetry even if it is symmetric according to the parameters. There is only one peaceful way for source to give and for sink to take. Source must be cost dominated and sink must be benefit dominated. Only then we will observe activity and superadditivity within the peaceful ensemble. To increase this superadditivity more substrate must be given peacefully from source to sink. This will only happen when source gives more while sink is able to take more. To make source give

more and sink take more mutations must increase cost in source and decrease cost in sink, increase  $K_m$  in source and decrease  $K_m$  in sink and finally decrease  $V_{max}$  in source and increase  $V_{max}$  in sink. However, this assumption is not completely identical to the observations in the course of evolution here (figure 6).

Figure 6

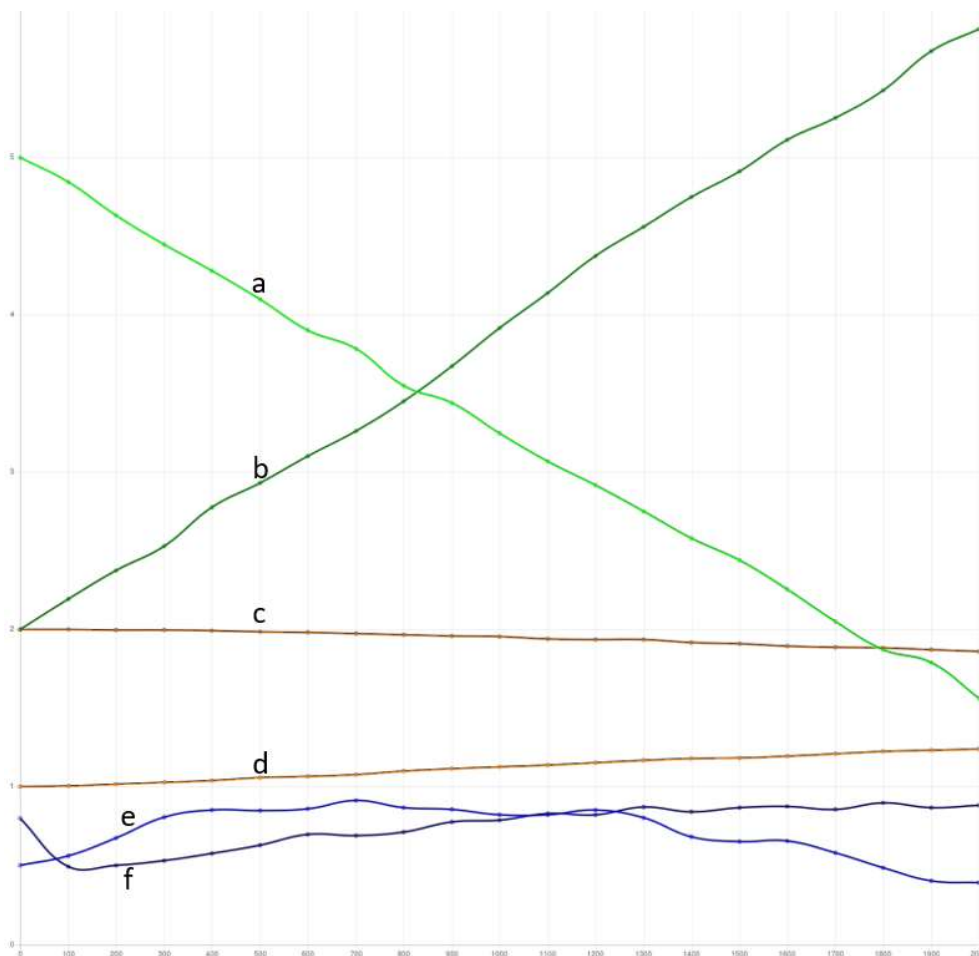

Figure 6

Here we observe the evolution of the mean values within a population of 9 organisms with 9\*3 identical, asymmetric ensembles as starting point (generation 0) according to: a,  $V_{max}$  source; b,  $V_{max}$  sink; c, cost sink; d, cost source; e,  $K_m$  source; f,  $K_m$  sink. The values are an average of the population and show the development during 2000 generations in the absence of recombination. With recombination the increase or decrease is steeper.

I observe partially an unexpected behaviour. In source, as expected,  $V_{max}$  drops, cost is increasing and  $K_m$  is also increasing but after about 700 generations (in this example)  $K_m$  is starting to decrease. In sink we observe besides an expected behaviour ( $V_{max}$  increasing,  $c_f$  decreasing and  $K_m$  initially decreasing) after about 100 generations an increasing  $K_m$  (figure 6). Why is  $K_m$  in both parties behaving so surprisingly by changing the direction of evolution? A  $K_m$  decrease has a larger effect on the productivity in lower concentrations and a  $V_{max}$  increase has a larger effect at higher concentrations. In addition, I set the mutational step size in cost to a small value. An increase in  $K_m$  looks like a decrease in cost.  $K_m$  in source is at first increasing, helping to transfer substrate from source to sink. At this generation time there are in source only large substrate concentrations (near 5mM). During the evolution of the system area I will increase in surface and include also smaller substrate concentrations for source and much larger concentrations for sink. Then  $K_m$  for source will decrease because it has now a more important additional effect on "increasing cost" helping to transfer to sink. The explanation for the behaviour of  $K_m$  in sink follows the opposite idea (low concentrations in the beginning). Despite this unexpected behaviour of the  $K_m$  value the overall increase in net profit is impressive.

The different velocity of the evolutionary progress in ensembles with recombination in contrast to ensembles without recombination is expected. It is known in Biology that recombination accelerates evolution (9, figure 7). In case there are early different mutations e.g. decreasing  $K_m$  in several sinks, the result is an advantage to every affected sink and its ensemble. Recombination will bring together such advantageous mutations of different levels into one organism.

A mutational step in sink increasing the net profit of the ensemble will increase benefit domination in sink. A mutational step in source

increasing the net profit of the ensemble will increase the cost domination in source. Therefore, source must be completely protected from competition with other sources. We observe a non-linear and then a linear phase of the graphs in figure 7. The linear phase seems to be a speed limit ( $np \cdot mM^2 / \text{generation} = \text{const.}$ ) in later generations when cost domination in source and benefit domination in sink have grown in those asymmetric ensembles. The speed limit depends on evolutionary velocity (with or without recombination). The loss of net profit in source and the gain (overcompensation) in sink correlate in a linear fashion.

Figure 7

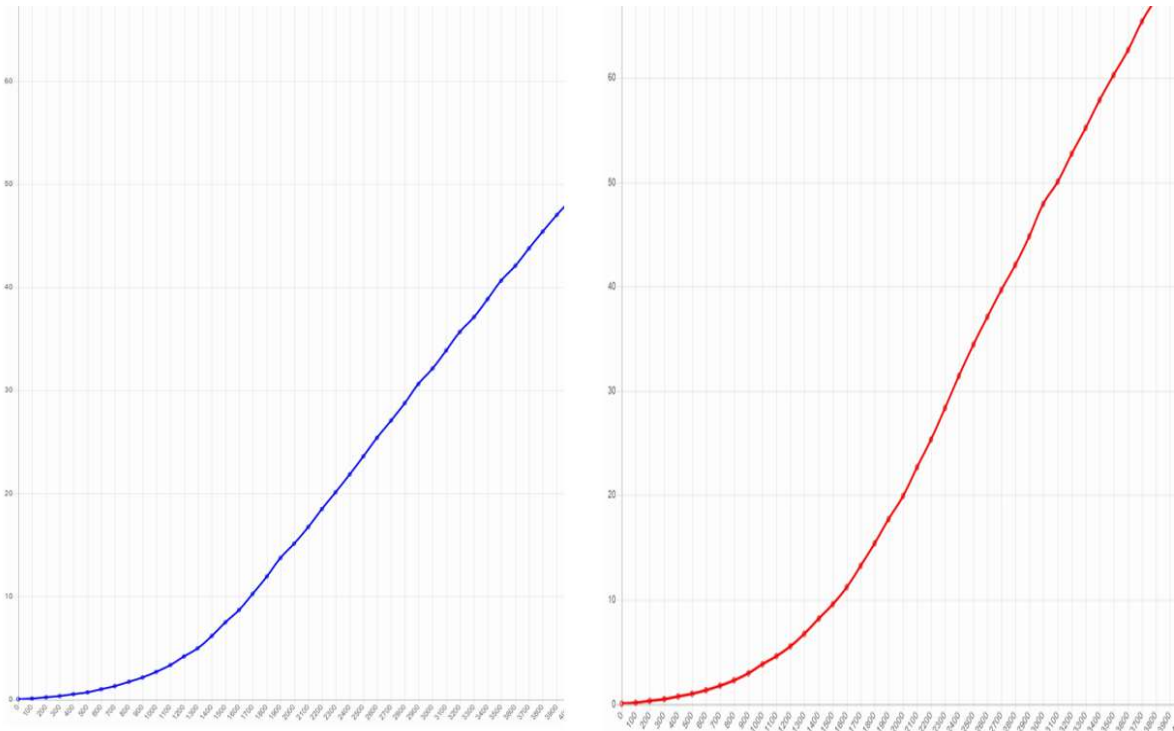

Figure 7

Here we observe the evolution of increasing superadditivity (average of the whole population) without recombination (blue) and with recombination (red). Both are from the same starting point of an asymmetric ensemble (figure 6). The y-coordinate has a step size of  $10mM^2 \cdot np$  ( $np$ , net profit of the ensemble of ensembles). The x coordinate is the generation time (4000 generations, same scale).



The increase in net profit is due to an increase of area I, the area of cost domination in source and benefit domination in sink. Now it would be interesting to learn in which way the shape of area I is changing. Therefore, the point  $b_{so}-c_{so}=b_{si}-c_{si}=0$  (figure 3) is observed and his movement during evolution of a peaceful ensemble. This is a very simple and straight forward approach. A more general idea would be a net profit vector for every concentration pair. The size of the vector is the net profit and the direction would be determined by the  $\tan\alpha$  of substrate concentration in source/substrate concentration in sink. The vectors of all pairs form the vector field. As long as the vector is outside of area I he would have the value zero. As soon as the concentration pair would fall into the growing area I we would observe the vector and could follow his increase. However, I prefer to follow the point  $b_{so}-c_{so}=b_{si}-c_{si}=0$ .

We start with 25 symmetric and asymmetric ensembles (figure 8). They all are characterized by the different starting position of the points where  $b_{so}-c_{so}=b_{si}-c_{si}=0$ . They all differ with respect to  $K_m$  and have identical values of  $cf=1$  and  $V_{max}=5$ . During the evolution towards higher net profit all  $25 \cdot 9 \cdot 3 \cdot 2 \cdot 3$  different values are changed by random mutation and recombination. I am going to observe how the path of  $b_{so}-c_{so}=b_{si}-c_{si}=0$  is behaving during evolution towards higher net profit.

All ensembles, wherever they start, develop towards complete asymmetry. The source evolves in a way that the substrate there is collected and then handed over to sink where the production of net profit takes place. At the end of our observation of the evolutionary process at 5000 generations the source practically does no longer keep substrate for its on productivity. Although many ensembles cross or start at the blue line of strict equivalence they don't stay there. The source becomes a collector of substrate and sink a place of main productivity of net profit (figure 8).

Figure 8

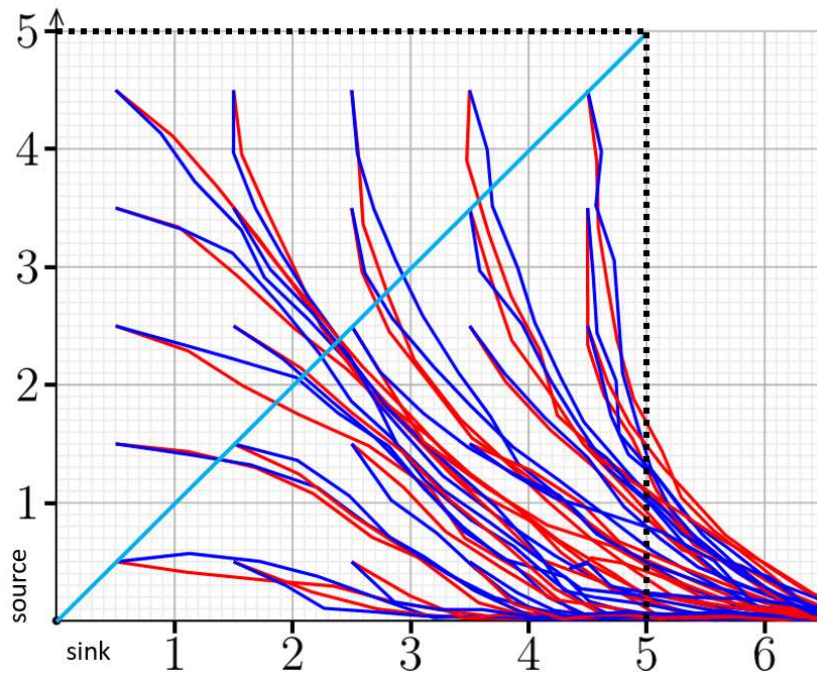

Figure 8

Here, we observe 25 points:  $b_{so}-c_{so}=b_{si}-c_{si}=0$  (figure 3) over the course of 5000 generations. The units of the two-dimensional coordinate system are mM substrate in y direction for source and x for sink. The asymmetric or symmetric ensembles start at 25 concentration pairs of source and sink: from 0.5mM/0.5mM to 4.5mM/4.5mM with steps of 1mM. The dimension net profit points towards the observer. The net profit increases from left to right and from top to bottom along the course of the red and blue lines. The dark blue lines – no recombination, the red lines – with recombination, light blue diagonal line – line of strict equivalence. All symmetric ensembles start on the blue diagonal. In sink the concentration limit of 5mM is exceeded to indicate the further development. When all substrate in source (max. 5mM) is transferred to sink (there then maximal 10mM) the process comes to an end.

At the end of the development  $b-c > 0$  in source becomes very small. The loss of the source seems a possibility. However, this will be prevented by:

- the service of source stays necessary as only the source is equipped to collect the substrate that is available to source;
- source could be sustained by direct reciprocity through sharing part of the superadditive net profit of sink;

- c. a high degree of biological reciprocity (genetic entanglement, 6), a lost source will always be replaced in the same process that will produce a new sink;
- d. evolutionary pressure is only acting on the ensemble as a whole.

The source can't be omitted as its service is still needed – not its productivity. The strong and effective asymmetry which is evolving will not be for free to the ensemble. There is no difference in the development with or without recombination. Following all the single paths towards asymmetry we can't observe a suboptimum or a very different path towards the final endpoint. Recombination only accelerates the development of asymmetry leading faster to higher net profit. The red paths may indicate some degree of sidedness of the transfer space.

The progress of a starting point  $b_{so}-c_{so}=b_{si}-c_{si}=0$  at 0.5mM/0.5mM is mainly in the sink direction (to the "right") while the progress of a starting point  $b_{so}-c_{so}=b_{si}-c_{si}=0$  at 4.5mM/4.5mM is mainly in the source direction ("downwards"). This is an indicator for the strong internal asymmetry of the transfer space. The reason is that at low concentrations of substrate in source and sink (0.5/0.5) an increase in net profit by any mutational step is larger in the direction of sink while at high concentrations of substrate in source and sink (4.5/4.5) an improvement of net profit by any mutation is larger in direction of source.

The evolutionary process detects the internal asymmetry although the outside seems to be symmetric. The same concentration range for source and sink.

Better ensembles will replace other ensembles with lower superadditivity. The appearance of subadditivity in area I through mutational steps

according to 5 will not survive as the total net-profit will decrease. A decreased net profit is going to be eliminated in an evolutionary process for improved net profit.

The activity of a peaceful master could be interpreted as a fix cost (brokerage fee). In figure 9 it is observed what happens to two asymmetric and one symmetric ensemble. However, the situation here is more difficult as we have additional points where  $b_{SO}-C_{SO}=b_{Si}-C_{Si}=0$  (figure 9, insets). For simplicity the old point only is observed. This time the path of the ensembles reasonably avoids the neighbourhood of the symmetric fix cost ( $f_c$ ) of 0.5 ( $c=cf*[S]+f_c$ ).

Figure 9

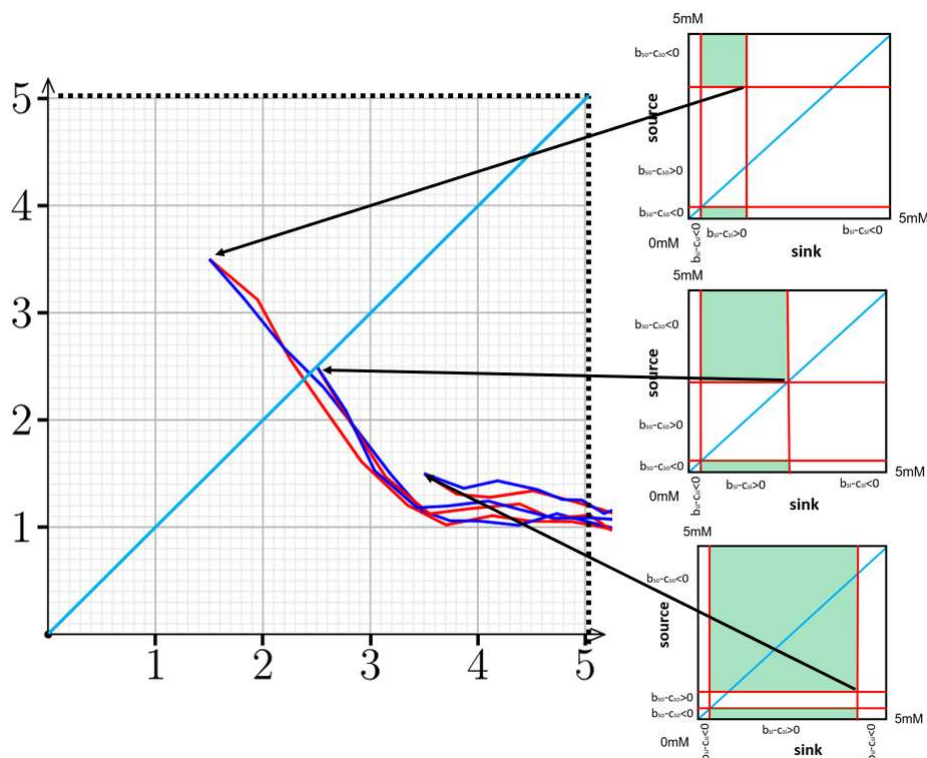

Figure 9

Again, the behaviour of the point  $b_{SO}-C_{SO}=b_{Si}-C_{Si}=0$  (figure 3) over the course of 5000 generations is observed in three ensembles with a symmetric fix cost. The insets symbolize the starting point of area I of the three ensembles. We see the green area I from variable cost and a small additional area where a transfer of the fix cost would bring additional net profit.

Organisms with connected basic ensembles:

This is the chapter to think about the benefit factor in more detail. A substrate is a Janus-headed thing. It looks on one side into the past where there are costs connected to the acquisition and ownership of the substrate. This is taken into account by a cost factor “cf”. On the other side the substrate looks into the future where the enzymatic transformation (or the manufacturing) will create a benefit from this substrate. This is taken into account by a benefit factor “bf”.

Up to know the benefit factor was primarily used to get rid of physicochemical dimensions (min,  $\mu\text{m}$ ) and to arrive at the dimension and placeholder “b”. In a connected ensemble (figure 4c) we look at a hierarchy of a production chain (enzymes in a cell or people in a company). The character of the substrates and materials along the production line change and increase in value and complexity but they may decrease in amount. 500 amino acids are assembled by different catalysts to form one protein molecule with a feature not available to all amino acids. More than 10 000 different parts are assembled by workers to form one car with a new feature emerging. The benefit factor is used to account for the increase in value, the change in character, the increase in complexity, and the loss in amount.

The benefit factor starts in this two-layered ensemble of ensembles with a value of 1 for the basic substrate and will increase with the next step in the production line. A first interpretation of the superadditive net profit of the basic layer: The superadditive net profit ( $mM^{2*np}$ ) of the lower level could be viewed as a new substrate (mM) to the higher level; a change of character and maybe amount. A second interpretation: The superadditive net profit ( $mM^{2*np}$ ) of the lower level is due to a better efficiency after transfer within those ensembles. Better efficiency could

be used to save substrate at the lower level. The same but now saved substrate (mM) is available to the higher level. The effect of 10mmoles of glucose on the growth of claws will be different from the effect of 10mmoles of glucose in a brain – not necessarily but hopefully with a higher value in the brain. The now saved substrate in the ensembles of a lower level has a higher leverage at a higher level but will also be of smaller amount. In the following connected ensembles  $bf$  is simply used to adjust the value of the superadditive net profit of a lower level ensemble and compensate for the loss in amount. Therefore, a change to e.g. lower  $K_m$  values is not necessary. After the size of  $bf$  is adjusted accordingly  $bf$  stays fixed. The benefit factor is not part of the evolutionary process as is the cost factor. This time the path of the point  $b_{so}-c_{so}=b_{si}-c_{si}=0$  during evolution is observed as an average again. However, we look at the average of the source-supplier and the sink-supplier of the top ensemble and the top ensemble separately. The superadditive net profit in the lower levels is calculated from 100 concentration steps (0mM-5mM, 50 $\mu$ M steps) and transfers from source to 100 concentration steps (0mM-5mM, 50 $\mu$ M steps) in sink. All 100\*100 net profits ( $mM^2*np$ ) of the lower level are converted to a concentration (mM) and multiplied by the same benefit factor (here 6) to maximally reach a “benefit concentration” of 5mM again. The result is a concentration range between 0mM and 5mM with a frequency distribution inherited from the lower level. All three ensembles still evolve with mutations in  $cf$ ,  $K_m$  and  $V_{max}$ . The superadditive net profit of the top ensemble is also determined by integration of 100\*100 columns and decides which organism is going to survive and have offspring, is only surviving or is going to die. Only asymmetric ensembles ( $b_{so}-c_{so}=b_{si}-c_{si}=0$ , 4mM source/1mM sink,) on all levels are observed. The ensembles evolve either without (figure 10) or with (figure 11) recombination.

Figure 10

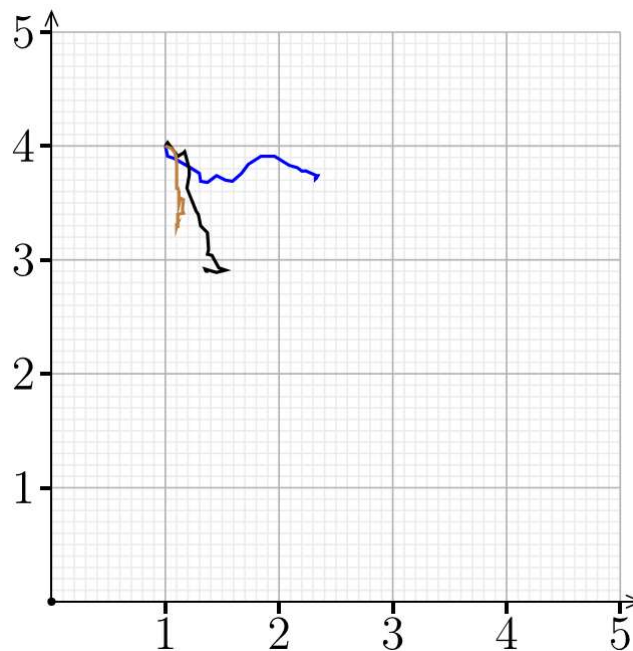

Figure 10

Evolutionary paths of a connected ensemble of ensembles with mutation only are observed. The paths are basically the evolution of the point  $b_{so}-c_{so}=b_{si}-c_{si}=0$  in the three connected ensembles over the course of 5000 generations within the concentration range of 5mM in source (y) and sink (x). The averages of groups of nine ensembles are displayed: blue - average of nine top ensembles, brown - average of nine ensembles providing the source side of the top ensemble, black - average of nine ensembles providing the sink side of the top ensembles.

Now, in the course of 5000 generations the concentration range (5mM\*5mM) is not left. The three paths appear erratic which is owed to the fact of a quite coarse calculation with steps of 50 $\mu$ M in combination with the interdependence of the mutations. The path direction of the top ensemble differs from the two paths of the supplier ensembles. The probability of all concentrations for the suppliers is the same. The top ensemble sees a frequency distribution. This distribution has the effect as different probabilities for certain concentration pairs would have.

In figure 11 the erratic behaviour is again observable. More important is the fact that recombination with its faster development identifies certain points  $b_{so}-c_{so}=b_{si}-c_{si}=0$  as optimal (star like appearance at the end).

Figure 11

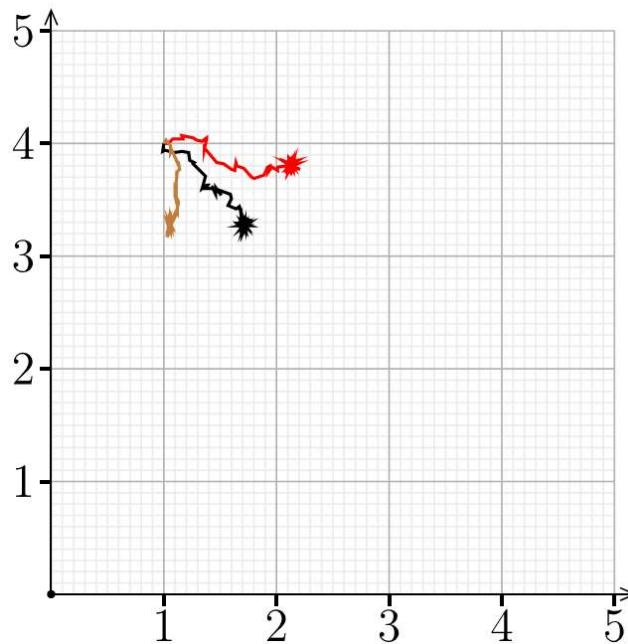

Figure 11

Evolutionary paths of a connected ensemble of ensembles with mutation and recombination are observed. The paths are basically the evolution of the point  $b_{so}-c_{so}=b_{si}-c_{si}=0$  in the three connected ensembles over the course of 5000 generations within the concentration range of 5mM in source (y) and sink (x). The averages of groups of nine ensembles are displayed: red - average of nine top ensembles, brown - average of nine ensembles providing the source side of the top ensemble, black - average of nine ensembles providing the sink side of the top ensembles.

A specific area I belongs to such points. This area does no longer grow. The net profit coming out of this area seems to be optimal with respect to the top ensemble and is growing further within those limits. The development of division of labour comes to an end. A further change in net profit and division of labour of the lower level ensembles is also punished. This roots in the unequal distribution of concentration pairs coming out of the suppliers. The evolutionary feed-back between the top ensemble and the supplier ensembles also stops the development. The reason, however, lies within the ensemble and not in a probabilistic structure of the outside world.



## General Discussion:

I have to emphasize that I am dealing here with a special case. We observe the behaviour of ensembles where source is benefit dominated and sink is cost dominated. The transfer will usually leave one side unsatisfied in a sense that all substrate that could be given or taken will not be taken or given. As soon as source is no longer cost dominated or sink is no longer benefit dominated transfer will stop completely whatever the other side would like to do. There will be no use of force and deception. We are dealing with an ensemble of two absolutely strong (can't be forced) and completely informed (can't be deceived) entities – two Homo Economicus. This ideal type of ensemble is only active in area I although all concentrations (concentration pairs) have the same probability.

The ability of source in the observed evolutionary process of the unconnected ensembles to endlessly worsen its own productivity by decreasing  $V_{max}$ , increasing cost and changing  $K_m$  appears insane. However, I observe a special case in a consequent way. It is not even necessary to locate source in direction of a substrate stream and shield the sink from this stream as all concentrations have the same probability. However, if this shielding from substrate would be the case we could observe the formation of a specialized (absorptive) tissues from an initially undifferentiated and completely symmetrical chunk of identical cells. But even a specialized tissue will need some basic residual productivity for itself. On the other side the increase in productivity is also insane. Sinks with a more complex structure will not be prepared for such a massive flow-through of substrate being converted to huge amounts of product and then handed over somewhere – possibly unprepared. The underlying, not yet adapted physical structures may

finally fail. The model needs internal limits but we can already learn something.

In some examples we have obviously observed the development from a completely symmetric and equal condition to an asymmetric, unequal condition. Asymmetry, inequality and division of labour can be found on different levels of complexity.

A case of symmetry breaking and a division of labour has recently been described in a model on the molecular level within an RNA-world setting (10). The model starts from a symmetric situation where the molecules have conflicting aims: minimize self-replication to increase “altruistic” catalysis and maximize selfish self-replication, one strand of the molecules remains catalytic and increases its copy number (enzyme-like molecules), whereas the other becomes non-catalytic and decreases its copy number (genome-like molecules). This asymmetry will increase the equilibrium cellular fitness. Both strands are a source and a sink at the same time. The catalytic active molecule is the source of products and a sink of information; on the other side the genome like molecule is the sink of products and the source of information. Therefore, they show a high degree of reciprocity and - never to forget - they are complementary strands. The character of reciprocity must not necessarily be of identical quality or quantity from molecules to higher animals (11) including primates.

Multicellular organisms are basically a clone of identical (equal, symmetric) cells. This seems to be sufficient in the beginning to gain an advantage over single celled organisms. In the course of evolution this equality is lost due to internal specialisation and division of labour (12, 13). On an even higher level of complexity animal societies like bees and ants show a great degree of division of labour (14). Here, we observe

one party collecting food and another party producing offspring. This relationship is stable as there is a huge degree of biological reciprocity (entanglement, 6). In addition, selection will be active mainly on the level of the whole ensemble. While an old interpretation was that the workers work for the queen, a different interpretation is also possible. The workers could be interpreted as a party producing younger sisters via the queen with a higher genetic similarity than own offspring would have (15). However, both is a misunderstanding of a two-dimensional entity in the three-dimensional ensemble. The old problem of conflicting micro-economic considerations and a macro-economic consideration.

Howsoever the original human societies may have looked like with different functional roles of male and female, old and young, hunter and non-hunter, gatherer and non-gatherer, today human societies are quite unequal with respect to many features (division of labour, distribution of wealth). The reasons of this inequality and the size of this inequality are under debate and contaminated with political aims and ideology. But even on the most basic level we already observe inequality and division of labour in man – our handedness (16).

Above I have described and discussed asymmetry and division of labour on different levels of complexity. Biologists are convinced that there are several major evolutionary transitions (17, 18) between those levels. The question is: Why do biologic and also economic systems (19) become more and more complex over time? On every level of molecular, organismic or economic complexity I see ensembles of sources and sinks. The simple examples are here the unconnected ensembles. They may just grow in size and number adding more and more unconnected parts. That is not yet a transition, it is only an increase in quantity which may look complex.

In the case of connected ensembles, we observe a really complex situation. Two ensembles of source and sink are themselves part of a new ensemble as source and sink; a transition. The new ensemble is more complex and becomes more integrated by limited increase in division of labour. The connected ensemble of ensembles is a model very similar to production chains and food chains. Both are basically pyramids with entities of small size but high number and low complexity at the bottom and a small amount of highly complex and quite large entities at the top. In Biology the substrate of a higher level is usually a highly complex ensemble of ensembles itself which is going to be disassembled before the smallest components are being reassembled to become part of the higher level (exceptions: e.g. slave holders – man and some ants). The benefit factor is a measure to what extent quantity is transformed into quality (20, 21) and the higher level is the place where it is decided whether this transformation is large enough to result in a superadditive net-profit. The benefit factor serves as a complexity indicator but not as complexity explainer. Explanation comes from the overall structure (connectiveness, information), the size relation of cost and benefit factors, and  $K_m$  and  $V_{max}$  in source and sink. Therefore, the benefit factor resembles the term “*transformity*”, a scaling factor introduced by D. M. Scienceman and H. T. Odum.

It should be clear that my model of three connected ensembles and two layers is only a starting point for much more complex applications using this model as a building block. The combinatorial potential of a more complex pyramid is very large especially as top levels may support sources or sinks in other levels of different range-depth. It is also imaginable to feed several top ensembles into one source or sink of a next level and make the assignment of the connections (the silk roads) between the ensembles accessible to change and evolution, too. On top,

the benefit factors could become a part of an evolutionary process as function of the output of other ensembles. The benefit factors ascending the pyramid must not necessarily increase along their path and the complexity may introduce additional cost. Some of those building blocks may stay interchangeable while others become of unique function and location. The degree of integration correlates here with a loss of exchangeability.

The way how a certain inequality and asymmetry evolves from equality and partial or complete symmetry but also from a complete opposite asymmetry has been investigated here. The different degree of substrate saturation of two identical compartments is sufficient to start an asymmetric relationship. As soon as we observe a source and a sink within an ensemble there will be asymmetry; even if all other internal parameters are identical and symmetric. Not necessarily the external asymmetry of substrate distribution but the internal asymmetric structure of the transfer space is important. Within the ensemble we find positive net profit at low substrate concentration and negative net profit at high substrate concentration. This inner asymmetry is detected and amplified by the evolutionary process. Evolution starts to increase the asymmetry, the beginning of a division of labour, leading to a substrate collector and supplier on one side and a substrate consumer and producer on the other side. This reminds of a potential difference. The larger the difference, the larger the force. The larger the force the more work a system can perform.

I have been looking at the selection pressure on the level of an ensemble of ensembles and the net profit there. Only a fully self-contained ensemble will behave as described. As soon as selection will also act on the single party source or sink or a single ensemble and the net profit there a more complex, interdependent behaviour will be observed. The

degree of isolation of the single party from competition with other, similar single parties will determine the intensity of inequality and division of labour, too. The degree of asymmetry and division of labour could in reverse be used as an indicator to what extent the single party (source and sink) is shielded by the ensemble from direct competition. In case this protection from competition with other, similar entities is lost the ensemble of the weaker entity will be harmed. On the other side the ensemble with the weak party may be able to make use of the better entity for itself with the price of a strategic dependence (Adam Smith, quote: "*It is maxim of every prudent master of a family never to attempt to make at home what it will cost him more to make than to buy. ... What is prudence in the conduct of every private family can scarce be folly in that of a great kingdom.*"). On top, there may be also harm to the ensemble with the stronger party through overextension by an additional participant. In a well-balanced ensemble there will be two wrong directions. It is easy to disturb a rehearsed team.

Finally, is it reasonable to choose the increase in net profit as an evolutionary bench mark? In short, yes! Many different, even antithetic types of net profit are imaginable. In addition, a positive net profit may appear as a negative net profit from another point of view because benefits and costs depend on their reference systems. The concepts "net profit" and "superadditive net profit" are not fixed to money. When we look at a positive net profit the benefit will be larger than the cost. A superadditive net profit is more net profit of an ensemble than simple additivity of net profit by two parties not transferring substrate at a certain concentration pair. A benefit is something to prefer and more benefit is preferable over less benefit but the costs always have to be considered. All this emerges from non-linearity. However, non-linearity is not a miracle it is a natural feature never violating the conservation laws.

## Literature

1. Chang TG, Zhu XG, Raines C (2017) Source-sink interaction: a century old concept under the light of modern molecular systems biology. *Journal of Experimental Botany*. Vol. 68(16):4417-4431
2. Turgeon TR (1989) The sink-source transition in leaves; *Annual Review of Plant Physiology and Plant Molecular Biology*. Vol. 40:119-138
3. van der Aalst WMP (2013) Business process management: a comprehensive survey. Hindawi Publishing corporation, ISRN Software Engineering, Article ID 507984
4. Friedrich T and Köpper W (2013) Schumpeter's Gale - Mixing and compartmentalization in Economics and Biology. MPRA\_paper\_45405
5. Friedrich T (2014) Work cycles of independent ensembles. MPRA\_paper\_55090
6. Friedrich T (2014) Entanglement by Genes or Shares; Hamilton's rule of kin selection revisited. MPRA\_paper\_60267
7. Friedrich T (2015) The limits of wise exploitation in dependent and independent symmetric ensembles. MPRA\_paper\_68250
8. Friedrich T (2016) Aquila non captat muscas: Homo Economicus between exploration and exploitation. MPRA\_paper\_75601
9. Felsenstein J (1974), The evolutionary advantage of Recombination. *Genetics* Vol. 78 no. 2:737-756
10. Takeuchi N, Hogeweg P, Kaneko K (2017) The origin of a primordial genome through spontaneous symmetry breaking. *Nat Commun*. No. 8, art. 250
11. Schweinfurth, MK and Taborsky M (2018) Reciprocal Trading of Different Commodities in Norway Rats. *Curr Biol* (28) 1-6
12. Kirk DL (2005) A twelve-step program for evolving multicellularity and a division of labor. *Bioessays* 27, 299–310
13. Ratcliff WC, Denison RF, Borrello M, and Travisano M (2011) Experimental evolution of multicellularity. *PNAS* 109, 1595–1600
14. Barker JL, Loope KJ, Reeve HK (2016) Asymmetry within social groups: division of labour and intergroup competition. *J Evol Biol* 29(3), 560-571
15. Bulmer MG and Taylor PD (1981) Worker-queen conflict and sex ratio theory in social Hymenoptera. *Heredity* 47(2) 197-207
16. Guiard Y (1987) Asymmetric division of labor in human skilled bimanual action: the kinematic chain as a model. *J Mot Behav* 19(4), 486-517
17. Szathmáry E and Smith JM (1995) The major evolutionary transitions. *Nature* 374(6519):227-32.
18. Szathmáry E (2015) Toward major evolutionary transitions theory 2.0. *PNAS* 112 (33) 10104-10111
19. Gowdy J and Krall L (2016) The economic origins of ultrasociality. *Behavioral and Brain Sciences*, 39, E92. doi:10.1017/S0140525X1500059X
20. Carneiro, RL (2000) The transition from quantity to quality: A neglected causal mechanism in accounting for social evolution. *Proc. Natl. Acad. Sci. U.S.A.* 97, 12926–12931
21. Odum, HT (1988) Self-Organization, Transformity, and Information. *Science* Vol. 242 (4882), 1132-1139