



Munich Personal RePEc Archive

Modified Charged System Search Algorithm for Economic Optimal Scheduling of Microgrid in Grid-Connected Mode

Jamaledini, Ashkan and Soltani, Ali and Khazaei, Ehsan

Electrical and Computer Engineering Department, Sazeh Sazan
Power Company, Iran, Electrical and Computer Engineering
Department, Sazeh Sazan Power Company, Iran, Electrical and
Computer Engineering Department, Sazeh Sazan Power Company,
Iran

2019

Online at <https://mpra.ub.uni-muenchen.de/95896/>
MPRA Paper No. 95896, posted 11 Sep 2019 05:40 UTC

Modified Charged System Search Algorithm for Economic Optimal Scheduling of Microgrid in Grid-Connected Mode

Ashkan Jamaledini, Ali Soltani, Ehsan Khazaei,

Electrical and Computer Engineering Department, Sazeh Sazan Power Company, Iran

Abstract: This paper presents a new heuristic algorithm famous as charged system search algorithm for optimal operation of the microgrids (MGs) in the grid-connected mode. The algorithm is also being modified based on a mutation operator technique to speed up its convergence speed. Finally, the model is examined on IEEE 69 bus test system.

I. INTRODUCTION

Microgrids (MGs) has higher reliability and resiliency due to closeness to the consumers. Also, as the transmission lines are reduced in the MGs, the total power losses, as well as the investment and operational costs of the entire grid is decreased. However, the optimal scheduling of the MGs would be more complicated as the MG can be connected and disconnected to the main grid. To this end, develop a fast and accurate algorithm for the optimal energy management of the MG is essential. This is mainly due to any fault would be lead to system blackout. To this end, this paper developed and presents a new algorithm known as the charged system search algorithm (CSSA) to overcome the complexity of the problem. Also, this algorithm can provide a fast convergence speed for optimal energy management of the MG. It should be noted that many heuristics methods

are suggested for the optimal energy management of the MGs. However, the proposed technique is very fast along with high accuracy and lower operation cost, compared to the well-known techniques such as particle swarm optimization (PSO) and genetic algorithm (GA).

II. GRID-CONNECTED MICROGRID MATHEMATICS

The main goal is cost minimization, given by

$$\min \sum_{\forall i} [C_i P_{it} I_{it} + SU_{it} + SD_{it}] \quad (1)$$

where I is a binary variable (0 or 1) that controls the status of unit i at time t . Also, SU and SD are the startup and shutdown costs.

In this paper, the following nomenclature is used:

UT and DT are minimum up and down

$T_{(on)}$ and $T_{(off)}$ are the number of successive on and off hours

RU and RD are the ramp up and down of the generators.

Moreover, the problem has some limitation, given by (2)- (6).

$$P_{it,min} \leq P_{it} \leq P_{it,max} \quad (2)$$

$$P_{it} - P_{i(t-1)} \leq RU_i \quad (3)$$

$$P_{i(t-1)} - P_{it} \leq RD_i \quad (4)$$

$$T_{(on)it} \geq UT_i(I_{it} - I_{i(t-1)}) \quad (5)$$

$$T_{(off)it} \geq DT_i(I_{i(t-1)} - I_{it}) \quad (6)$$

This paper proposed and adopted a new heuristic method known as the charged system search algorithm for the MG operation. This technique is taken from [12]. Also, a

mutation operator is considered to speed up the convergence speed of the algorithm. Results shows the higher speed of the algorithm compare to the PSO and GA.

III. SIMULATION RESULTS

Fig. 1 shows the IEEE 69 along with 4 DGs.

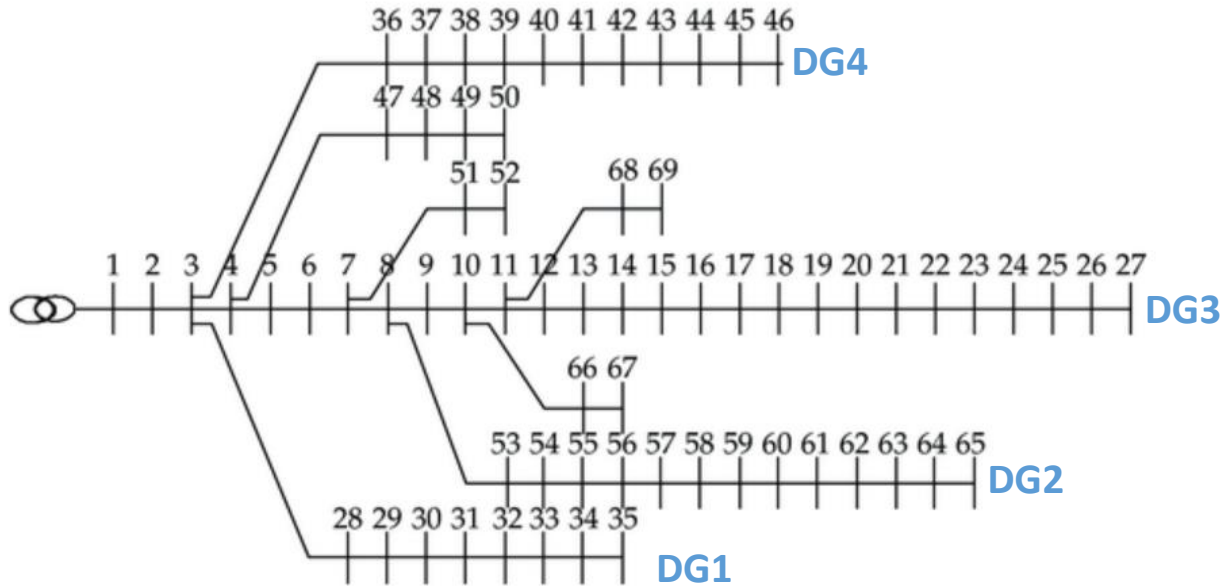

Fig. 1. IEEE 69 bus test system diagram

DGs feature are in Table I.

Table I
DGs features

	Minimum output power	Maximum output power
DG1	20	400
DG2	40	450
DG3	10	250
DG4	10	250

Load demand of the network are presented in Fig. 2.

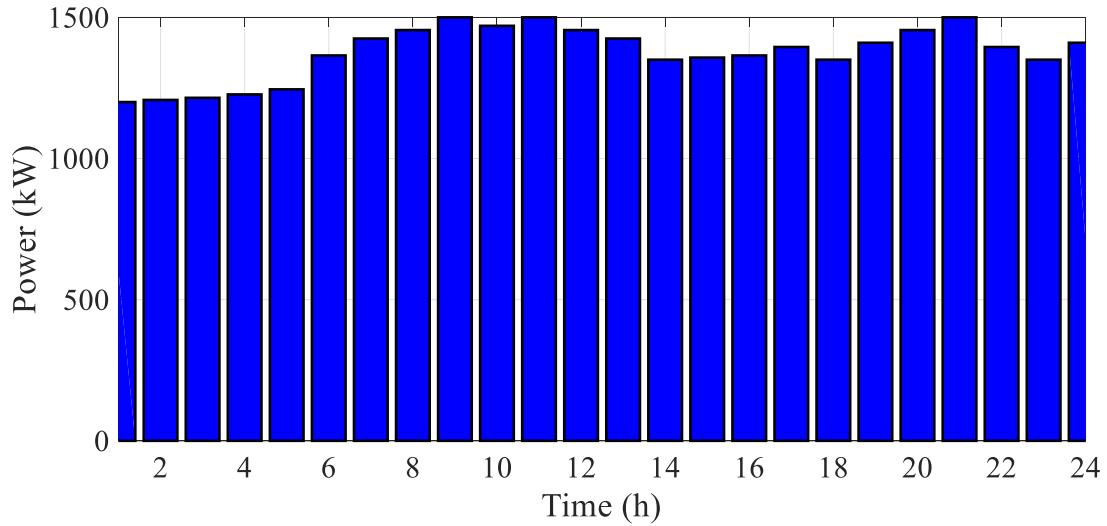

Fig. 2. Load demand of the network

DGs output power are mainly based on the economic perspective as shown in Fig. 4. The active DGs is the first DG where it has lower price.

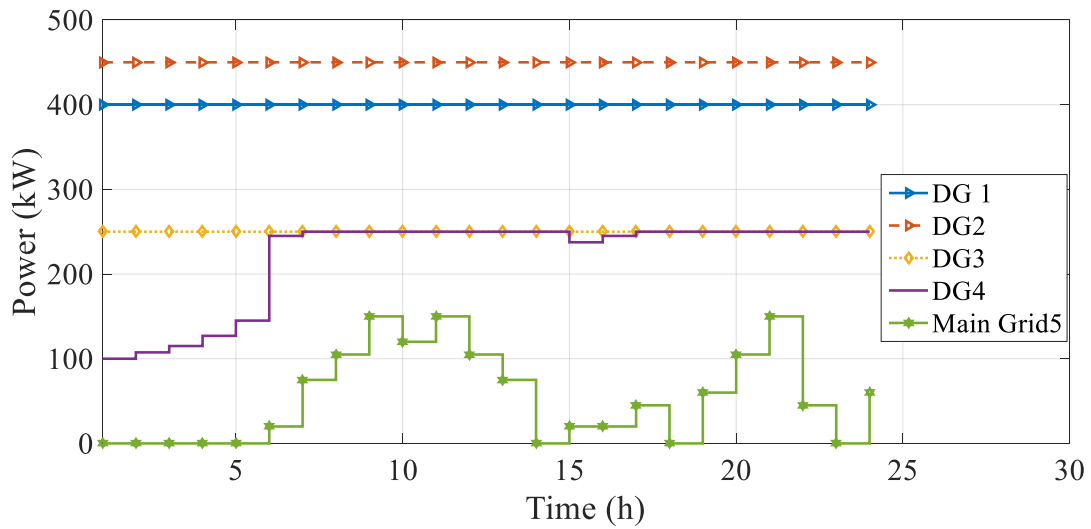

Fig. 3. Produced powers by DGs

Table II compare the operation cost and convergence speed of the algorithm. The results prove the effectiveness of the proposed model.

Table II

Cost of operation for several methods

	cost (\$)	Convergence (s)
PSO	637335	11.1
GA	623437	9.9
Proposed method	534534	7.3

IV. CONCLUSION

Charged system search algorithm is one of the powerful heuristics techniques that has been used in this paper for optimal energy management of the grid-connected MG. Results shows that compare to the PSO and GA, this method has higher convergence speed, which is one of the key points in MG operation. In addition, it has lower operation cost for the MG operation compare to GA and PSO.

Reference

- [1] Vasquez, Juan C., Josep M. Guerrero, Alvaro Luna, Pedro Rodríguez, and Remus Teodorescu. "Adaptive droop control applied to voltage-source inverters operating in grid-connected and islanded modes." *IEEE transactions on industrial electronics* 56, no. 10 (2009): 4088-4096.
- [2] Tajalli, Seyede Zahra, Seyed Ali Mohammad Tajalli, Abdollah Kavousi-Fard, Taher Niknam, Morteza Dabbaghjamesh, and Shahab Mehraeen. "A Secure Distributed Cloud-Fog Based Framework for Economic Operation of Microgrids." In *2019 IEEE Texas Power and Energy Conference (TPEC)*, pp. 1-6. IEEE, 2019.
- [3] Dabbaghjamesh, Morteza. "Stochastic Energy Management of Reconfigurable Power Grids in the Presence of Renewable Energy by Considering Practical Limitations." (2019).
- [4] Taherzadeh, Erfan, Shahram Javadi, and Morteza Dabbaghjamesh. "New Optimal Power Management Strategy for Series Plug-In Hybrid Electric Vehicles." *International Journal of Automotive Technology* 19, no. 6 (2018): 1061-1069.

- [5] Jiang, Quanyuan, Meidong Xue, and Guangchao Geng. "Energy management of microgrid in grid-connected and stand-alone modes." *IEEE transactions on power systems* 28, no. 3 (2013): 3380-3389.
- [6] Najy, Waleed KA, Hatem H. Zeineldin, and Wei Lee Woon. "Optimal protection coordination for microgrids with grid-connected and islanded capability." *IEEE Transactions on industrial electronics* 60, no. 4 (2012): 1668-1677.
- [7] Al-Saedi, Waleed, Stefan W. Lachowicz, Daryoush Habibi, and Octavian Bass. "Power flow control in grid-connected microgrid operation using Particle Swarm Optimization under variable load conditions." *International Journal of Electrical Power & Energy Systems* 49 (2013): 76-85.
- [8] Zeineldin, H. H., E. F. El-Saadany, and M. M. A. Salama. "Distributed generation micro-grid operation: Control and protection." In *2006 Power Systems Conference: Advanced Metering, Protection, Control, Communication, and Distributed Resources*, pp. 105-111. IEEE, 2006.
- [9] Zitzler, Eckart, and Lothar Thiele. "An evolutionary algorithm for multiobjective optimization: The strength pareto approach." *TIK-report* 43 (1998).
- [10] Chen, Yahong, Changhong Deng, Weiwei Yao, Ning Liang, Pei Xia, Peng Cao, Yiwang Dong et al. "Impacts of stochastic forecast errors of renewable energy generation and load demands on microgrid operation." *Renewable Energy* 133 (2019): 442-461.
- [11] Fathi, Mohammad, and Hassan Bevrani. "Statistical cooperative power dispatching in interconnected microgrids." *IEEE Transactions on Sustainable Energy* 4, no. 3 (2013): 586-593.
- [12] Kaveh, A., and S. Talatahari. "A novel heuristic optimization method: charged system search." *Acta Mechanica* 213, no. 3-4 (2010): 267-289.
- [13] Kavousi-Fard, Abdollah, Morteza Dabbaghjamanesh, Jie Zhang, and Omid Avatefipour. "Superconducting Fault Current Limiter Allocation in Reconfigurable Smart Grids." *arXiv preprint arXiv:1905.02324* (2019).
- [14] Wang, Boyu, Morteza Dabbaghjamanesh, Abdollah Kavousi Fard, and Shahab Mehraeen. "Cybersecurity Enhancement of Power Trading Within the Networked Microgrids Based on Blockchain and Directed Acyclic Graph Approach." *IEEE Transactions on Industry Applications* (2019).
- [15] Saberi, Hossein, Shahab Mehraeen, and Boyu Wang. "Stability improvement of microgrids using a novel reduced UPFC structure via nonlinear optimal control." In *2018 IEEE Applied Power Electronics Conference and Exposition (APEC)*, pp. 3294-3300. IEEE, 2018.

- [16] Dabbaghjamanesh, Morteza, Boyu Wang, Shahab Mehraeen, Jie Zhang, and Abdollah Kavousi-Fard. "Networked Microgrid Security and Privacy Enhancement By the Blockchain-enabled Internet of Things Approach." In 2019 IEEE Green Technologies Conference (GreenTech), pp. 1-5. IEEE, 2019.
- [17] Dabbaghjamanesh, Morteza, Boyu Wang, Abdollah Kavousi-Fard, Shahab Mehraeen, Nikos D. Hatziargyriou, Dimitris Trakas, and Farzad Ferdowsi. "A Novel Two-Stage Multi-Layer Constrained Spectral Clustering Strategy for Intentional Islanding of Power Grids." IEEE Transactions on Power Delivery (2019).
- [18] Radwan, Amr Ahmed A., and Yasser Abdel-Rady I. Mohamed. "Analysis and active-impedance-based stabilization of voltage-source-rectifier loads in grid-connected and isolated microgrid applications." IEEE Transactions on Sustainable Energy 4, no. 3 (2013): 563-576.
- [19] Hafez, Omar, and Kankar Bhattacharya. "Optimal planning and design of a renewable energy based supply system for microgrids." Renewable Energy 45 (2012): 7-15.